

<https://caseihservicemanual.com>

Vibratory Rollers SV212 and SV216

Service Manual

<https://caseihservicemanual.com>

NOTE: CASE Company reserves the right to make changes in the specification and design of the machine without prior notice and without incurring any obligation to modify units previously sold.

The description of the models shown in this manual has been made in accordance with the technical specifications known as of the date of design of this document.

CONTENTS

SECTION 00 - MAINTENANCE

CHAPTER 1 - General Instructions

Description	Page
Introduction	1
Safety instructions.....	3
Environmental measures and health precautions.....	6
Product identification.....	8
Torque specifications.....	9

CHAPTER 2 - General Specifications

Description	Page
Description of the machine	1
Fluids and lubricants.....	2
Specifications.....	5
Overall machine dimensions.....	9

CHAPTER 3 - Troubleshooting

Description	Page
Troubleshooting - Engine.....	2
Troubleshooting - Hydraulic system oil overheating - emulsifying.....	3
Troubleshooting - Vibration.....	3
Troubleshooting - Travel.....	5
Troubleshooting - Brakes.....	6
Troubleshooting - Steering.....	6

SECTION 10 - ENGINE

CHAPTER 1 - Removal and installation

Description	Page
Specifications.....	1
Description.....	2
Torque specifications.....	4
Special tools.....	4
Removal.....	6
Installation.....	13
Accelerator cable assembly removal and installation.....	13

SECTION 21 - TRANSMISSION

CHAPTER 1 - Hydraulic motor

Description	Page
Description	2
Specifications.....	3
Torque specifications	3
Disassembly.....	3
Reconditioning and replacement	5
Assembly	8

CHAPTER 2 - Travel reduction gear

Description	Page
Specification.....	1
Torque specifications	2
Special tools.....	2
Exploded view of travel brake	6
Disassembly and assembly	7
Brake test.....	9
Exploded view.....	10
Disassembly and assembly	11

SECTION 29 - HYDROSTATIC DRIVE

CHAPTER 1 - Pumps - Cento drive coupling

Description	Page
Specifications.....	1
Tightening torque	1
Description	2
Special tools.....	3
Removal of pumps, Cento clutch	3
Cento drive coupling	7

SECTION 35 - HYDRAULIC SYSTEM

CHAPTER 1 - Hydraulic cylinders

Description	Page
Torque Specifications	1
Description	2
Special tools.....	3
Hood hydraulic cylinders.....	5
Cab hydraulic cylinder.....	7
Hydraulic cylinders.....	7

CHAPTER 2 - Vibration Motor

Description	Page
Description	2
Specifications	3
Torque specifications	3
Disassembly	3
Assembly	9
Supply pressure relief valve adjustment	13

CHAPTER 3 - Hydraulic circuit

Description	Page
Hydraulic installation	2
Functional description	2
Travel without activation	3
Travel activated, moving forward	4
The multi-function valve	5
The idler-wheel lock-block on the flow divider	6
ASC valve	7
Vibration hydraulics	8
Vibration without activation	8
Vibration activated	9
Steering hydraulics	10
Steering without activation	11
Steering to the right	12
Lifting hydraulics	13
Lifting of the cab or hood	14
Lowering the cab and hood	15
Reservoir hydraulics	16
Hydraulic reservoir	16
Discharging of closed circuits	17
Brake release - emergency towing	18
Test points	19
Releasing transmission and wheel hydraulic motor brakes	20
Hydraulic diagram	22

CHAPTER 4 - Hydraulic pump

Description	Page
Specifications	1
Torque specifications	1
Description	2
Disassembly	3
Reconditioning and replacement of parts	8
Assembly	14
Inspection and adjustments	26

SECTION 39 - FRAMES

CHAPTER 1 - Drum

Description	Page
Description	2
Specifications.....	4
Torque specifications	4
Special tools.....	4
Drum removal	7
Vibrator plate assembly	14
Removal of the right side of the drum	16
Inspection and adjustment of vibration frequency.....	19

CHAPTER 2 - Articulation

Description	Page
Specifications.....	1
Torque specifications	1
Description	2
Special tools.....	3
Disassembly.....	4

CHAPTER 3 - Drum Segments and Scrapers

Description	Page
Specifications.....	1
Hardware torque	1
Special tools.....	1
Description	2
Segment installation.....	3

SECTION 41 - STEERING

CHAPTER 1 - Control

Description	Page
Specifications.....	1
Special tools.....	1
Description	2
Fault finding - steering	3
Disassembly and assembly of steering wheel	3

CHAPTER 2 - Steering cylinders

Description	Page
Specifications.....	1
Special torques	1
Special tools.....	2
Removal of steering cylinders.....	3
Replacing the seals.....	4

CHAPTER 3 - Steering control valve

Description	Page
Specifications.....	1
Tightening torques.....	1
Description.....	2
Special tools.....	3
Disassembly.....	4
Reassembly.....	7
Functional check.....	12

SECTION 50 - HEATER - AIRCONDITIONING**CHAPTER 1 - Removal and installation**

Description	Page
Specifications.....	1
Removal.....	2
Defects in the airconditioning system.....	4
Replacing (tightening) the belt.....	5

SECTION 55 - ELECTRICAL CIRCUIT**CHAPTER 1 - Wiring diagram**

Description	Page
Electrical installation.....	1

SECTION 90 - PLATFORM, CAB**CHAPTER 1 - Operator's compartment**

Description	Page
Torque specifications.....	1
Operator's compartment.....	2
Travel brake control adjustment.....	8

<https://casehservicemanual.com>

SECTION 00 - MAINTENANCE

Chapter 1 - General Instructions

Section	10000	Description	Page
CONTENTS			
		Introduction	1
		Safety instructions	2
		Environmental measures and health precautions	5
		Product identification	7
		Torque specifications	8

INTRODUCTION

This series of Vibratory Rollers is suitable for compaction of all kinds of ground and for large and average-scale groundwork in highway construction (construction of motorways, railways, airports), in hydro-engineering (construction of dams), in building construction (industrial areas, ports), and the like.

These machines are manufactured in conformity with the latest developments and standards, which ensure their safe function.

If the machine is used incorrectly, by untrained operators or for other purposes than those stipulated above, there is a danger of an accident or damage to the equipment.

The main purpose of this manual is to give the information necessary for carrying out assembly and disassembly of the machine as well as service repairs of main assemblies of the equipment. It contains technical and installation data, instructions on how to adjust the machine and how to use special tools, fixtures and aids.

The manufacturer continuously seeks to make product improvements on the basis of experience and latest developments in the field.

For this reason, the manufacturer may make some changes in drawings, descriptions and designs in this manual.

<https://caseinsertmanual.com>

RIGHT, LEFT, FRONT AND REAR OF THE MACHINE

As used in this manual, the terms “right”, “left”, “front” and “rear” indicate the sides of the machine as seen from the operator’s seat.

- A. FRONT
- B. REAR
- C. RIGHT-HAND SIDE
- D. LEFT-HAND SIDE

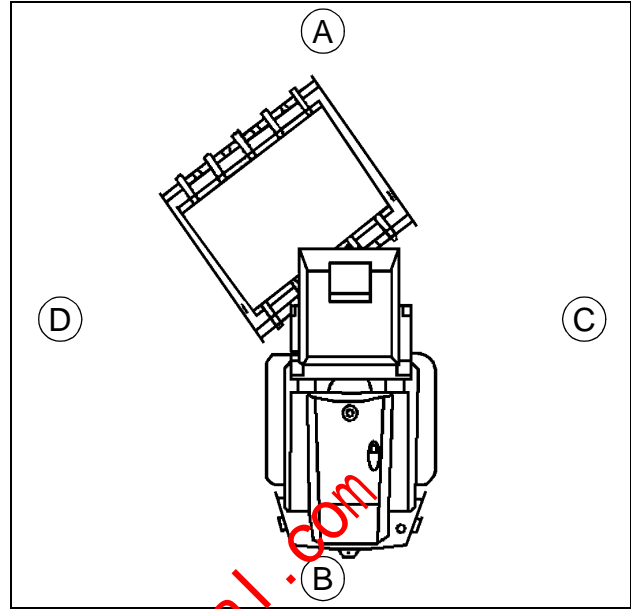

CS00M511

1

SAFETY INSTRUCTIONS

GENERAL SAFETY INSTRUCTIONS

The following safety instructions must be observed by ALL repairing the machine.

1. Repairs may be carried out by skilled, trained and experienced personnel only.
2. When performing repairs, always use our shop manual. Special instructions for the assembly work are given in individual chapters of the manual.
3. Before putting the machine into operation acquaint yourselves with the machine controls as explained in the "Operator's Manual" and make sure that you are perfectly familiar with the machine.
4. Do not use the machine if you do not fully understand all controls and until you know how the machine works.
5. Familiarize yourself with the area where you will work.
6. Do not carry out any redesign work or modifications on the machine because you could compromise the safety of the equipment.
7. Original parts and accessories have been designed especially for this machine.
8. Installation and use of spare parts not supplied by the manufacturer of the machine or not authorized by him can have negative effects on operational characteristics and safe operation of the machine.
7. Attach a "Do not operate" warning note to the steering wheel and leave it there for the duration of the service work.
8. Wash the equipment thoroughly. If you use steam, do not expose electrical components and insulation directly to the steam, or otherwise cover them beforehand.
9. Keep all parts absolutely clean when dismantling, mounting, and servicing each assembly. Protect removed parts from getting soiled.
10. Clean the surface of dismantled parts and do the necessary to ensure adequately dust-free working conditions and a suitable storage area.
11. Be careful when handling cleaning agents. Do not use petrol or other easily inflammable materials for cleaning.
12. Dry the cleaned parts and immediately cover with anticorrosive protective oil- never install corroded parts.
13. Tools, hoists, safety equipment on chains, and other additional items must be serviceable and in good condition.
14. Use hoists and fasteners (ropes, chains) that have sufficient lifting capacity and are in good condition.
15. Make sure that there is enough fresh air supply when starting up the equipment in an enclosed area.

REPAIRING AND INSPECTING THE MACHINE

1. Wear working clothes and boots.
2. Use gloves when handling oils, fuel or coolant.
3. Protect your eyes with goggles or a shield when handling the battery.
4. Place the equipment on a flat and firm surface before starting repair. Secure the machine to prevent spontaneous movement.
5. Secure the frame of the machine and the drum to prevent rotation using a locking pin and a draw bar.
6. Before starting work remove the ignition key, disconnect the batteries and let hot parts cool down.

16. Before operating the equipment make sure there is nobody on the machine or close by. Starting up of the machine must always be announced with an audible alarm, also after any pause in operation before the equipment is restarted. Those present on the machine and dangerously close by must leave the machine after the alarm has been sounded.
17. Do not adjust moving equipment.
18. When working (adjusting) on a running engine, avoid touching hot and rotating parts. During work on a running engine, another person must be present that can easily access the emergency switch and must be in contact at all times with the person performing the adjustment, to be able to switch off the engine immediately when necessary.
19. Use only approved makes of motor, gear and hydraulic oil and coolant.
10. Fill new components with hydraulic oil before installation.
11. Rinse the hydraulic circuit after replacing a hydraulic component; clean the hydraulic reservoir as well.
12. Replace the oil filter cartridge.
13. Fill the hydraulic circuit with pure oil of the recommended viscosity, but only when the engine has been stopped.
14. Wipe off excess oil.
15. Check connections for tightness and any oil leaks, before applying pressure to the system.
16. Do not adjust safety valves.
17. After all work has been finished, recheck all connections and replace all safety items.
18. After finishing the work put all protective devices back in place.
19. After putting the machine into operation.
 - Check the level in the hydraulic reservoir.
 - Check the output pressure of hydraulic pumps if they have been replaced as well as safety valve pressure. Carry out the measurements at a temperature of 40°C (104°F).

WORKING ON HYDRAULIC CIRCUITS

1. Make sure that no hydraulic circuit is under pressure before opening it. Hydraulic oil leaks under pressure may penetrate your skin and cause serious injury.
2. Mark all parts, hoses and pipes before removing them.
3. Do not operate hydraulic pumps and hydraulic motors without oil.
4. There is danger of being scalded when handling hot oil.
5. Do not warm oil to temperatures above 160°C (320°F)- oil or its fumes may ignite.
6. For cleaning and wiping hydraulic parts use such textiles that do not leave traces of lint.
7. When reassembling parts use hydraulic oil - not grease - as a lubricant.
8. Clean screws and bolts carefully before installation, wash hoses and pipes and blow them through using compressed air.
9. Always use new packing in sealing areas.

WORKING ON THE FUEL SYSTEM

Mixtures of gasoline and diesel (winter fuel) are as inflammable as gasoline.

1. Do not refuel in closed areas.
2. Wipe off excess fuel.
3. Do not smoke when working on the fuel system and do not use naked lights. There is a danger of fire.

WORKING ON ELECTRICAL WIRING

1. Disconnect the battery when carrying out any repairs on the charging circuit to avoid accidental short-circuits.
2. When dismantling, first disconnect the cable from the negative pole (-), then the cable from the positive one (+).
3. Do not disconnect batteries when the engine is running.
4. Connect the "minus" pole of the battery to the chassis and the "plus" pole to terminal "B+" from the alternator. In case of opposite connection the whole semi-conductor device can be destroyed.
5. When starting with an auxiliary external supply, do not disconnect the supply sooner than the battery of the machine is connected. Make sure of the starting voltage of the auxiliary external supply (for 24 V).
6. Do not put the alternator into no-load operation, i. e. with the wire disconnected from the "+" terminal and connected to the "D+" terminal.
7. Do not check the presence of voltage in the wire by sparking it on the chassis of the equipment.
8. Do not do anything that produces sparks.
9. When handling batteries, use protective rubber gloves and goggles.
10. Protect your skin and clothes from stains caused by electrolyte or lead particles.
11. If electrolyte gets into your eye, rinse it with running water for a few minutes. Then see a doctor as soon as possible.
12. When electrolyte stains your skin or clothes, take off your clothes, wash the stained area with soapy water or with a solution of baking soda and water and see a doctor.
13. In the event of accidentally swallowing electrolyte, drink as much milk or water as possible or a solution of milk of magnesia and immediately see a doctor.
14. Never pour distilled water into the cells unless the operation of the machine or charging outside the machine follows. In this case the battery would discharge rapidly.

15. Never add sulfuric acid (H_2SO_4).
16. Do not overturn the batteries because electrolyte could run out of the air vents in the battery.
17. If acid (electrolyte) is spilled, rinse the area with water and neutralize it with lime.
18. When the batteries are being charged, hydrogen is released and, mixed with air, makes an explosive, easily combustible mixture. Do not use naked lights and do not smoke.

WELDING ON THE MACHINE

Before starting arc welding, disconnect all parts with semi-conductors from electrical wiring, i.e.:

- engine alternator,
- hourmeter,
- control unit under the instrument panel,
- earth both the supply and the machine that is being repaired,
- protect the supply point against moisture,
- place the ground terminal close to the welded joint,
- when parts are welded or when the machine is in the suspended position, insulate the point of current transfer to avoid current entering the hoist, or use a non-conducting rope.

SEALS

1. Always use new packing.
2. You can obtain packing kits in spare part form.

HARDWARE TORQUE

1. Use a torque wrench to obtain the right hardware torque.
2. Fastening screws and nuts of the given grade are tightened according to the table.
3. Screw grade is shown visibly on the screw head.
4. Hardware torque is given in the tables.
5. Threaded connections of hydraulic circuits are tightened as specified in the tables.
6. The given hardware torque specifications are valid for dry screw threads.
7. Use new self-locking nuts only.

ENVIRONMENTAL MEASURES AND HEALTH PRECAUTIONS

When repairing the machine, observe the general principles of health protection and environment protection, along with all laws, regulations, and guidelines related to these problems, as applicable to the territory where the machine is used.

HYGIENE

1. Oil products, coolants, battery acids, and paints including thinners can be harmful to your health and they can cause serious injury.
2. It is necessary to observe consistently safety and health instructions enclosed with the products and to use personal protective aids when handling them.
3. Personnel in contact with these products during servicing must observe the general principles relating to conservation and keep in mind safety and health guidelines as given by manufacturers of such products, especially the following:
 - protection of eyes and skin when working with batteries,
 - protection of the skin when handling oil products, paint, and coolants,
 - workers should wash their hands properly after finishing their work and apply proper healing hand lotions,
 - when working with the cooling system it is necessary to observe the instructions in the manuals supplied with the machine.
4. Oil products, coolants, batteries, and paint including organic thinners as well as cleaners and preservatives should be always stored in their original packaging and properly labeled. Do not store such products in unlabeled bottles and other containers because there is a danger of confusion. Confusion with food or drinks is especially dangerous.
5. If your skin or eyes are by accidentally splashed or fumes inhaled, apply first aid immediately. In case of accidental consumption of such products see your doctor immediately.

ECOLOGICAL PRECAUTIONS

1. Contents of machine systems and some parts of the machine, when no longer in use, represent great risks to the environment.
2. The following products especially belong to this category:
 - both organic and synthetic lubricating materials, oils and fuel,
 - coolants,
 - battery acids and batteries themselves,
 - cleaning agents and preservatives,
 - all removed filters and filter elements,
 - all used and discarded hydraulic and fuel hoses, rubber - metals and the other elements exposed to the above products.
3. The above parts and materials must be handled, after they had been discarded, in accordance with prevailing national regulations on environmental protection and in conformance with directives relating to health conservation.
4. When hydraulic liquids, fuel, cooling systems and their components are being removed it is necessary to prevent their infiltration into the ground by using retaining vessels and by plugging all orifices.
5. In the event of leakage, the contaminated area must be immediately dried with sawdust, Vapex, or similar.
6. Contaminated earth must be removed to prevent further infiltration. Then the soil and absorbing material must be disposed of safely.

FIRE PRECAUTIONS

1. From a fire risk point of view, the inflammable liquids used are divided into the following risk classes

II. Risk class

- oil

IV. Risk class

- mineral oils

- lubricants

- antifreeze

2. The place where oil is being changed must not be situated in an area where there is danger of explosions or fire.
3. Notices showing that smoking and naked lights are not allowed must be installed there.
4. The receptacles used to catch drained inflammable liquids must be of adequate capacity.
5. Portable fire-extinguishers must be available.
6. Oil and oil products should be handled in special containers, e.g. metal barrels, drums or cans.
7. Liquid containers must be properly closed when stored.
8. The containers should have an air vent. They should be always stored with the air vent up and there must be measures taken to prevent leakage.
9. The vessels must be labeled with indelible inscriptions showing their contents and inflammability class.

<https://casehservicemanual.com>

PRODUCT IDENTIFICATION

Serial and type numbers are important for machine identification and/or in case of warranty claims. A name plate with basic machine data is attached to the left side of the frame below the cab.

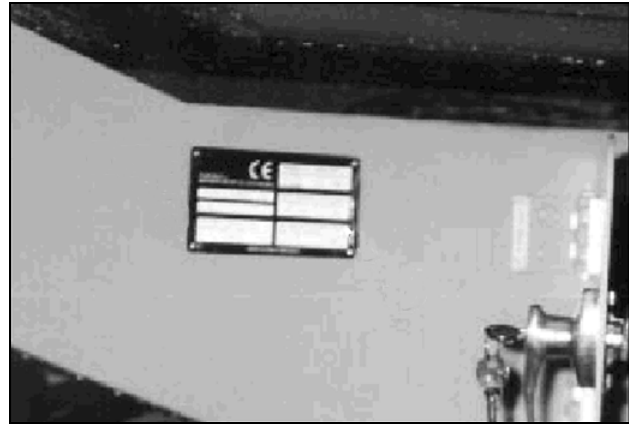

CD00M008

2

A plate with the serial number of the Cummins engine is attached to the fuel injection pump drive housing.

Serial numbers and data relating to major components may be found on the components concerned.



CD00M009

3

TORQUE SPECIFICATIONS

FASTENING HARDWARE

Inspection and re-tightening

1. Regularly check that hardware is not loose.
2. Use torque limiting wrenches to tighten screws and nuts.

Screws with metric threads

Screw size	Torque					
	For screws 5.8 (5 S)		For screws 8.8 (8 G)		For screws 10.9 (10 K)	
	Nm	lb-ft	Nm	lb-ft	Nm	lb-ft
M4	2	1	3	2	4	3
M5	4	3	6	4	8	6
M6	7	5	10	7	14	10
M8	16	12	22.5	17	32.5	24
M10	31.5	23	44	32	62	46
M12	53	39	75	55	105	77
M14	79	58	118	87	165	122
M16	113	83	165	122	226	167
M18	172	127	245	181	343	253
M20	226	167	314	232	441	325
M22	284	209	392	289	559	412
M24	392	289	549	405	755	557

NOTE: Lock nuts may be used a maximum of 3 times when approved.

https://caseinsertmanual.com

SCREW TYPE HOSE CONNECTIONS

			Screw type connections with "O" Rings					
			Nm			lb-ft		
Wrench size	Thread	Hose	Nominal	Min	Max	Nominal	Min	Max
14	M12x1.5	6	20	15	25	15	11	18
17	M14x1.5	8	38	30	45	28	22	33
19	M16x1.5	8	45	38	52	33	28	38
		10						
22	M18x1.5	10	51	43	58	38	32	43
		12						
24	M20x1.5	12	58	50	65	43	37	48
27	M22x1.5	14	74	60	88	55	44	65
		15						
30	M24x1.5	16	74	60	88	55	44	65
32	M26x1.5	18	105	85	128	77	63	92
36	M30x2	20	135	115	155	100	85	114
		22						
41	36x2	25	166	140	192	122	103	142
46		28						
50	M42x2	30	240	210	270	177	155	199
50	M45x2	35	290	265	325	214	188	240
	M52x2	38	330	280	380	243	207	280
		42						

<https://caseinsertmanual.com>

PLUGS AND NECKS

Table of tightening torques for necks and plugs with tightening edge, or with flat packing:

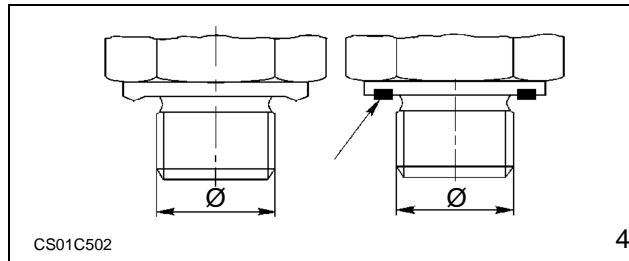

CS01C502

4

Ø	Neck torque	
	Nm	lb-ft
G 1/8"	25	18
G 1/4"	40	30
G 3/8"	95	70
G 1/2"	130	96
G 3/4"	250	184
G 1"	400	295
G 1 1/4"	600	443
G 1 1/2"	800	590
M 10x1	25	18
M 12x1.5	30	22
M 14x1.5	50	37
M 16x1.5	60	44
M 18x1.5	60	44
M 20x1.5	140	103
M 22x1.5	140	103
M 26x1.5	220	162
M 27x1.5	250	184
M 33x1.5	400	295
M 42x1.5	600	443
M 48x1.5	800	590

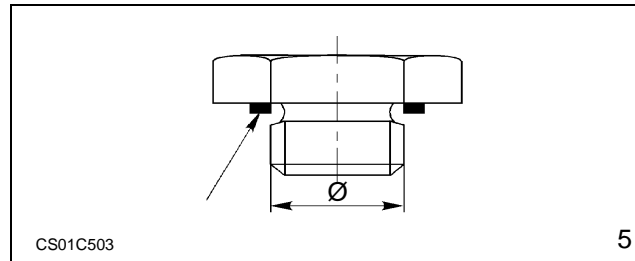

CS01C503

5

Ø	Plugs torque	
	Nm	lb-ft
G 1/8"	15	11
G 1/4"	33	24
G 3/8"	70	52
G 1/2"	90	66
G 3/4"	150	111
G 1"	220	162
G 1 1/4"	600	443
G 1 1/2"	800	590
M 10x1	13	10
M 12x1.5	30	22
M 14x1.5	40	30
M 16x1.5	60	44
M 18x1.5	70	52
M 20x1.5	90	66
M 22x1.5	100	74
M 26x1.5	120	89
M 27x1.5	150	111
M 33x1.5	250	184
M 42x1.5	400	295
M 48x1.5	500	369

NOTES

<https://caseinservicemanual.com>

SECTION 00 - MAINTENANCE

Chapter 2 - General Specifications

Section	10000	Description	Page
CONTENTS			
		Description of the machine	1
		Fluids and lubricants	2
		Specifications	5
		Overall machine dimensions	9

DESCRIPTION OF THE MACHINE

This vibratory roller is a self-propelled compaction machine consisting of two articulated sections, i.e. the drum and the towing unit.

Drum unit

This consists of the frame in which the drum with the travel drive and vibration drive is placed. Two levels of amplitude, which can be selected together with the corresponding frequency, make it possible to compact materials with different characteristics. Two scrapers placed on the front side of the beam and on the rear side on the cross member of the drum frame are provided for removing any soil adhering to the drum.

Articulation

Connects both units of the roller and enables independent horizontal and vertical movement of both sections.

Towing unit

This consists of a welded frame with the articulation support and hydraulic travel motors in front and the fuel tank, batteries and tool box to the rear. The hydraulic reservoir, operator's compartment and ROPS frame are mounted on top.

The static linear load and dynamic parameters for this machine place it in the heavy vibratory roller category.

<https://caseservicemanual.com>