

SERVICE MANUAL

Hydraulic Excavator

9007B

7-22241

1. Trim along dashed line.
2. Slide into pocket on Binder Spine.

TYPE 1-4

SERVICE MANUAL

Hydraulic Excavator

9007B

7-22241

1. Trim along dashed line.
2. Slide into pocket on Binder Spine.

TYPE 1-4

SERVICE MANUAL

Hydraulic Excavator

9007B

7-22241

1. Trim along dashed line.
2. Slide into pocket on Binder Spine.

TYPE 1-4

SERVICE MANUAL

Hydraulic Excavator

9007B

7-22241

1. Trim along dashed line.
2. Slide into pocket on Binder Spine.

TYPE 1-4

<https://caseih.servicemanual.com>

9007B HYDRAULIC EXCAVATOR

Table of contents

DIVISION/SECTION	SECTION N°	REFERENCE N°
1 GENERAL		
Safety, general information and torque specifications	1001	7-21930GB
Specifications	1002	7-23020
2 ENGINE		
Engine removal and installation	2000	7-21950GB
Radiator and oil cooler	2001	7-21960GB
Diesel engine specifications details	2402	
3 FUEL SYSTEM		
4 ELECTRICAL		
Electrical schematics	4001	7-22810
Battery testing, maintenance and booster battery connections	4002	7-22000GB
5 STEERING		
Tracks, rollers and idlers	5002	7-22020GB
6 POWER TRAIN		
Travel motor and travel reduction gear	6002	7-22030GB
Swing motor and swing reduction gear	6003	7-22041GB
7 BRAKES		
8 HYDRAULICS		
Cleaning the hydraulic system	8000	7-22050GB
Hydraulic schematic, inspections, adjustments and troubleshooting	8001	7-22820
Hydraulic pump	8002	7-22070GB
Attachment, swing and travel control valves	8003	7-22081GB
Attachment and dozer blade cylinders	8004	7-22090GB
Hand control valves, foot control valves, shuttle valve, travel shuttle valve and accumulator	8005	7-22100GB
Electro-control valve block	8006	7-22110GB
Cushion valve	8007	7-22120GB
Auxiliary hydraulics	8008	
Hydraulic pilot filter, hydraulic inline filter and bypass oil filter	8011	
Hydraulic swivel	8013	7-22150GB
9 MOUNTED/EQUIPMENT		
Upperstructure and turntable bearing	9002	7-22160GB
Boom, arm, bucket and blade	9003	7-22170GB
Seat mounting and belts	9004	
Cab and cab equipment	9005	7-26100
Air conditioner troubleshooting	9006	
Air conditioner system service	9008	
Air conditioner components service	9009	
Hydraulic and electrical schematics foldout	in rear pocket	7-22611
Hydraulic and electrical schematics foldout (options)	in rear pocket	

Sections to be distributed at a later date

Reprinted

<https://caseihservicemanual.com>

Section

1001

**SAFETY, GENERAL INFORMATION
AND TORQUE SPECIFICATIONS**

<https://caseihservicemanual.com>

TABLE OF CONTENTS

GENERAL INFORMATION	3
SAFETY.....	4
STANDARD TORQUE DATA FOR CAP SCREWS AND NUTS.....	6



WARNING : *This symbol is used in this manual to indicate important safety messages. Whenever you see this symbol, carefully read the message that follows, as there is a risk of serious injury.*

<https://caseihservicemanual.com>

GENERAL INFORMATION

Cleaning

Clean all metal parts except bearings, in a suitable cleaning solvent or by steam cleaning. Do not use caustic soda for steam cleaning. After cleaning, dry and put oil on all parts. Clean oil passages with compressed air. Clean bearings in a suitable cleaning solvent, dry the bearings completely and put oil on the bearings.

Inspection

Check all parts when the parts are disassembled. Replace all parts that have wear or damage. Small scoring or grooves can be removed with a hone or crocus cloth. Complete a visual inspection for indications of wear, pitting and the replacement of parts necessary to prevent early failures.

Bearings

Check bearings for easy action. If bearings have a loose fit or rough action replace the bearing. Wash bearings with a suitable cleaning solvent and permit to air dry. DO NOT DRY BEARINGS WITH COMPRESSED AIR.

Needle bearings

Before you press needle bearings in a bore always remove any metal protrusions in the bore or edge of the bore. Before you press bearings into position put petroleum jelly on the inside and outside diameter of the bearings.

Gears

Check all gears for wear and damage. Replace gears that have wear or damage.

Oil seals, O-rings and gaskets

Always install new oil seals, O-rings and gaskets. Put petroleum jelly on seals and O-rings.

Shafts

Check all shafts that have wear or damage. Check the bearing and oil seal surfaces of the shafts for damage.

Service parts

Always install genuine Case service parts. When ordering refer to the Parts Catalog for the correct part number of the genuine Case replacement items. Failures due to the use of other than genuine Case replacement parts are not covered by warranty.

Lubrication

Only use the oils and lubricants specified in the Operator's or Service Manuals. Failures due to the use of non-specified oils and lubricants are not covered by warranty.

SAFETY



*This symbol means **ATTENTION! BECOME ALERT! YOUR SAFETY IS INVOLVED.** The message that follows the symbol contains important information about safety. Carefully read the message. Make sure you fully understand the causes of possible injury or death.*

To prevent injury always follow the Warning, Caution and Danger notes in this section and throughout the manual.

Put the warning tag shown below on the key for the keyswitch when servicing or repairing the machine. One warning tag is supplied with each machine. Additional tags Part Number 331-4614 are available from your service parts supplier.



WARNING: Read the operator's manual to familiarize yourself with the correct control functions.



WARNING: Operate the machine and equipment controls from the seat position only. Any other method could result in serious injury.



WARNING: This is a one man machine, no riders allowed.



WARNING: Before starting engine, study Operator's Manual safety messages. Read all safety signs on machine. Clear the area of other persons. Learn and practice safe use of controls before operating.

It is your responsibility to understand and follow manufacturer's instructions on machine operation, service and to observe pertinent laws and regulations. Operator's and Service Manuals may be obtained from your Case dealer.



WARNING: If you wear clothing that is too loose or do not use the correct safety equipment for your job, you can be injured. Always wear clothing that will not catch on objects. Extra safety equipment that can be required includes hard hat, safety shoes, ear protection, eye or face protection, heavy gloves and reflector clothing.



WARNING: When working in the area of the fan belt with the engine running, avoid loose clothing if possible, and use extreme caution.



WARNING: When doing checks and tests on the equipment hydraulics, follow the procedures as they are written. **DO NOT** change the procedure.



WARNING: When putting the hydraulic cylinders on this machine through the necessary cycles to check operation or to remove air from a circuit, make sure all people are out of the way.



WARNING: Use insulated gloves or mittens when working with hot parts.



WARNING: Lower all attachments to the ground or use stands to safely support the attachments before you do any maintenance or service.



WARNING: Pin sized and smaller streams of hydraulic oil under pressure can penetrate the skin and result in serious infection. If hydraulic oil under pressure does penetrate the skin, seek medical treatment immediately. Maintain all hoses and tubes in good condition. Make sure all connections are tight. Make a replacement of any tube or hose that is damaged or thought to be damaged. DO NOT use your hand to check for leaks, use a piece of cardboard or wood.



WARNING: When removing hardened pins such as a pivot pin, or a hardened shaft, use a soft head (brass or bronze) hammer or use a driver made from brass or bronze and a steel head hammer.



WARNING: When using a hammer to remove and install pivot pins or separate parts using compressed air or using a grinder, wear eye protection that completely encloses the eyes (approved goggles or other approved eye protectors).



WARNING: Use suitable floor (service) jacks or chain hoist to raise wheels or tracks off the floor. Always block machine in place with suitable safety stands.



WARNING: When servicing or repairing the machine, keep the shop floor and operator's compartment and steps free of oil, water, grease, tools, etc. Use an oil absorbing material and/or shop cloths as required. Use safe practices at all times.



WARNING: Some components of this machine are very heavy. Use suitable lifting equipment or additional help as instructed in this Service Manual.



WARNING: Engine exhaust fumes can cause death. If it is necessary to start the engine in a closed place, remove the exhaust fumes from the area with an exhaust pipe extension. Open the doors and get outside air into the area.



WARNING: When the battery electrolyte is frozen, the battery can explode if (1), you try to charge the battery, or (2), you try to jump start and run the engine. To prevent the battery electrolyte from freezing, try to keep the battery at full charge. If you do not follow these instructions, you or others in the area can be injured.

STANDARD TORQUE DATA FOR CAP SCREWS AND NUTS

Tightening of cap screws, nuts

Tighten alternately so that tightening torque can be applied evenly. The numbers in the figure below indicate the order of tightening.

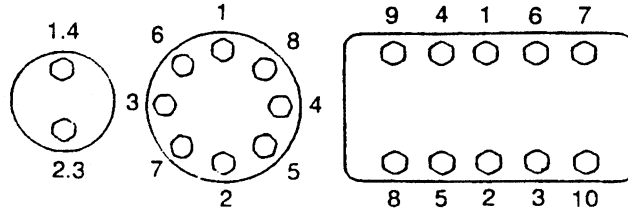

JS00481A

Apply engine oil to the thread portion of the cap screw so that uniform tightening torque is obtained. The cap screws and nuts that cannot be inspected externally or those as indicated in the assembly/installation sections should be saftied with lockwire, cotter pin or bent washer.

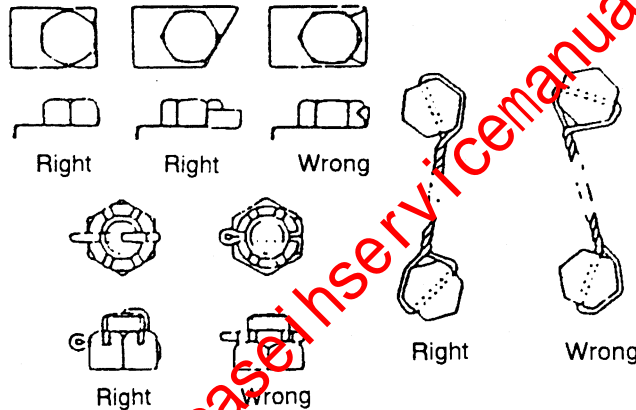

JS00482A

Cap screws which have had Loctite used (white residue remains after removal) should be cleaned with light oil or suitable cleaning solvent and dried. Apply 2-3 drops of Loctite to the thread portion of the cap screw and then tighten.

Torque table

Tighten cap screws and nuts according to the table below if there are no other special instructions.

Cap Screw Name Size (Size)			M6	M8	M10	M12	M14	M16	M18	M20
Cap Screw	Spanner	[mm]	10	13	17	19	22	24	27	30
		[in.]	0.39	0.51	0.67	0.75	0.87	0.95	1.06	1.18
	Tightening torque	[Nm]	6.9	15.7	32.3	58.8	98.0	137.2	196.0	274.0
		[lb-ft]	5.1	11.6	23.9	43.4	72.3	101.2	144.6	202.4
Socket Head Cap Screw	Spanner	[mm]	5	6	8	10	12	14	14	17
		[in.]	0.20	0.24	0.32	0.39	0.47	0.55	0.55	0.67
	Tightening torque	[Nm]	8.8	21.6	42.1	78.4	117.6	176.4	245.0	343.0
		[lb-ft]	6.5	15.9	31.1	57.8	86.8	130.1	180.8	253.1

<https://caseihservicemanual.com>

<https://caseihservicemanual.com>

Section

1002

SPECIFICATIONS

<https://caseihservicemanual.com>

TABLE OF CONTENTS

FLUIDS AND LUBRICANTS	3
Hydraulic fluid.....	3
Final drive gear boxes.....	3
Grease	3
Engine oil	4
Oil viscosity/Oil range.....	4
Fuel	5
Anti-freeze/Anti-corrosion.....	5
Capacities	5
ENVIRONMENT	5
SYSTEMGARD LUBRICATION ANALYSIS PROGRAM	6
MACHINE GENERAL SPECIFICATIONS	6
Engine	6
Hydraulic system.....	6
Undercarriage	7
Indicators and gauges.....	7
Weights	7
Arm.....	7
Dozer blade.....	7
Tracks, Rollers and Idlers	8
Gauge table.....	14
MACHINE OVERALL DIMENSIONS.....	16
WORKING RANGE	17

<https://caseih.servicemanual.com>

FLUIDS AND LUBRICANTS

Lubricants must have the correct properties for each application.



WARNING : *The conditions of use for individual fluids and lubricants must be respected.*

Hydraulic fluid

Use only hydraulic oils meeting Case specifications or equivalent AW (anti-wear) hydraulic oils.

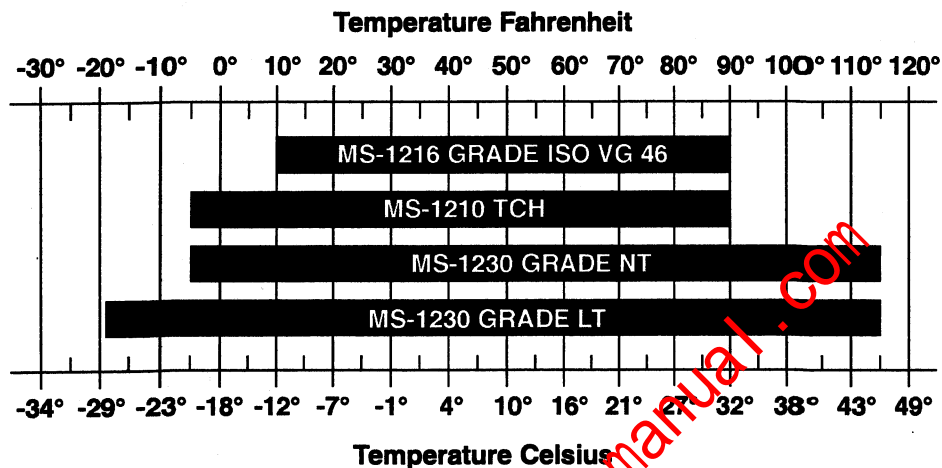

CS99B506

NOTE : *Case specification MS-1210 TCH Fluid is used in place of ISO VG 32 (-5 to +65°F) and ISO VG 46 (+10 to +90°F).*

Case specifications MS-1230 Grade NT or Grade LT is used in place of ISO VG 32 (-5 to +65°F), ISO VG 46 (+10 to +90°F), ISO VG 100 (+30 to +115°F), and MS-1210 TCH.

Final drive gear boxes

Extreme pressure oil used for enclosed transmission components.

Extreme pressure oil type API GL5 grade 80W90 or ISO VG 150 or CASE 135H Gear lube.

Grease

No. 2 EP Lithium Grease or Molydisulfide Grease.

Engine oil

CASE N°1 motor oil is the oil recommended for your engine. This oil ensures correct lubrication of your engine in all working conditions.

If CASE N°1 Multiperformance or Performance engine oil cannot be obtained, use only oil of the API/CG/CF category.

NOTE : Do not put any Performance Additive or other additive in the sump. Oil change intervals shown in the Operator's manual are based on tests carried out on CASE lubricants.



RD97F136



RB97F100

Oil viscosity/Oil range

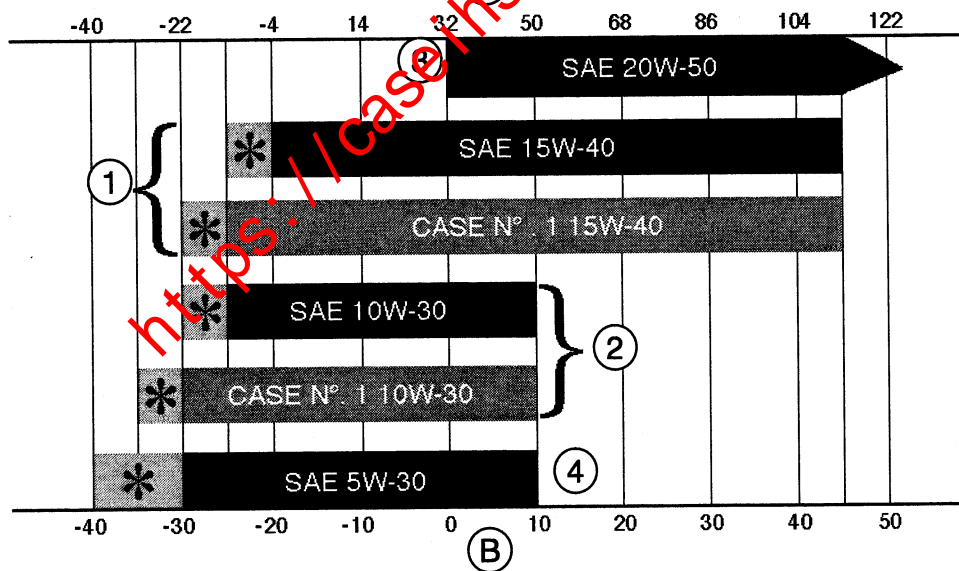

CS98M561

(A) Fahrenheit Temperature

(B) Celsius Temperature

(1) All seasons

(2) Winter

(3) Tropical

(4) Arctic

(*) Use of an engine oil heater, or engine coolant heater is required.

Fuel

Use fuel which is to ASTM (American Society for Testing and Materials) D975 standard.

Use grade N°2 fuel. The use of other types of fuel can result in a loss of power and may cause high fuel consumption.

When the temperature is very cold, the use of a mixture of N°1 and N°2 fuel is permitted. See your fuel vendor for winter fuel requirements in your area.

If the temperature falls below the fuel cloud point (point at which wax begins to form) the wax crystals will cause power loss or will prevent the engine from starting.

IMPORTANT : *In cold weather, fill the fuel tank at the end of the day's work, in order to prevent the formation of condensation.*

Capacities

Engine Oil Capacity - with Filter Change	6.8 liters	1.8 U.S. gallons
Engine Cooling System	10.1 liters	6.7 U.S. gallons
Fuel Tank	140 liters	37 U.S. gallons
Hydraulic Oil Tank Capacity	56 liters	14.8 U.S. gallons
Total Hydraulic System Capacity	95 liters	25 U.S. gallons
Final Drive Case Capacity	1.7 liters	1.8 U.S. quarts
Lower Rollers.....	120 to 130 cc	4 to 4.4 oz
Upper Rollers.....	50 to 55 cc	1.7 to 1.8 oz
Front idler wheels	70 to 75 cc	2.4 to 2.5 oz

NOTE : *These capacities are only a guide to the quantities. Always use the dipstick, sight gauges or level plug to make sure that fluid levels are correct.*

ENVIRONMENT

Before carrying out any maintenance operation on this machine and before disposing of used fluids or lubricants, always think of the environment. Never throw oil or fluid on the ground and never place it in leaking receptacles.

Fuel storage

Long storage can lead to the accumulation of impurities and condensation in the fuel. Engine trouble can often be traced to the presence of water in the fuel.

The storage tank must be placed outside and the temperature of the fuel should be kept as low as possible. Drain off water and impurities regularly.

Anti-freeze/Anti-corrosion

Use anti-freeze in all seasons to protect the cooling system from corrosion and all risk of freezing.

For areas where ambient temperature is over -36°C (-33°F), use a blend of 50% ethylene-glycol based anti-freeze.

For areas where the temperature is below -36°C (-33°F), it is advisable to use a blend of 40% water and 60% anti-freeze.

Contact your local ecological recycling center or your CASE Dealer to obtain information on the correct method of disposing of these materials.

SYSTEMGARD LUBRICATION ANALYSIS PROGRAM

Ask your CASE Dealer about our Lubricant Analysis Program, Systemgard. Through this service, your lubricants are tested in an independent laboratory. You simply remove a sample of lubricant from your machine and send the sample to the Systemgard laboratory. After the sample is processed, the laboratory will report back to you and guide you with maintenance requirements. Systemgard can help support your equipment up time and provide you with a service that can pay back dividends when you trade for another piece of CASE equipment.

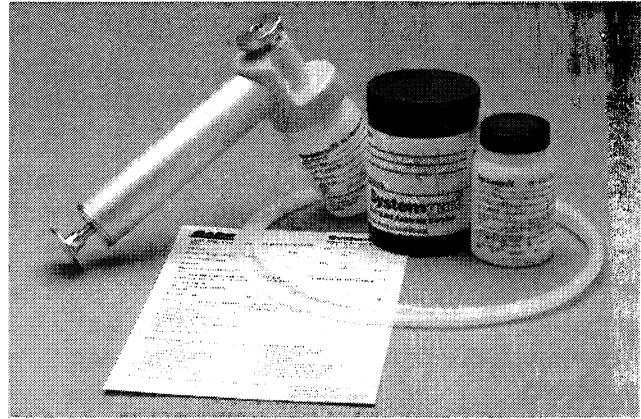

BP97H063

MACHINE GENERAL SPECIFICATIONS

Engine

Make and type ISUZU A-4JB1
 Number of cylinders..... 4
 Bore/stroke 93 mm x 102 mm (3.66 in x 4.02 in)
 Displacement.....2771 cm³ (169 cu in)
 Cooling Anti-freeze mix water
 Battery start..... 2-12 volt batteries

Working conditions

Speed 2100 rpm
 Power : ECC 1289 40.4 kW (53.4 ch)
 Capacity : Engine oil (with filter change)..... 6.8 liters (1.8 U.S. gallons)
 Fuel tank 140 liters (37 U.S. gallons)

Hydraulic system

Two variable displacement, axial piston type pumps for supplying attachments, swing and travel motors.

Main pump output..... 2 x 75.6 L/mn (2 x 20 gpm)

One pump for supplying the dozer blade

Maximum dozer blade pump displacement 25.5 L/mn (6.7 gpm)

Circuit relief valve

Attachment 4410 PSI (30.4 MPa)

Swing 2988 PSI (20.6 MPa)

Travel 4120 PSI (28.4 MPa)

Dozer blade 3263 PSI (22.6 MPa)

Control valves

Five sections control valve for left-hand travel, boom acceleration, arm, option circuit and swing.

Four sections control valve for right-hand travel, boom, arm acceleration and bucket.

One section control valve for the dozer blade.

Load holding valve on boom and arm.

Swing

Fixed flow, piston-type pump.

Disk brake.

Upperstructure swing speed 13.5 rpm

Travel

Variable displacement, axial piston type hydraulic motors.

Planetary reduction gears.

Low speed 0 to 2.3 mph (0 to 3.7 kph)

High speed 0 to 3.1 mph (0 to 5 kph)

Gradeability 70%

Tractive effort 49 kN (11 023 lb)

Bucket force (with 1.74 m/5 ft 7 in arm) 55.4 kN (12 454 lb)

Arm force (with 1.74 m/5 ft 7 in arm) 38.9 kN (8745 lb)

Hydraulic reservoir capacity 56 liters (14.8 U.S. gallons)

Total hydraulic system capacity 95 liters (25 U.S. gallons)

Undercarriage

One-piece frame with welded components.

Lubricated track rollers and idler wheels.

Grease cylinder track tension system.

Steel tracks width 450 mm and 600 mm (17.7 in and 23.6 in)

Rubber tracks width 450 mm (17.7 in)

Ground pressure (with 450 mm/17.7 in pads) 4.9 PSI (3.3 kpa)

Chain guide in front

Indicators and gauges

Engine coolant solution temperature, fuel level and hourmeter.

Engine oil pressure, coolant temperature and hydraulic fluid temperature, battery charge, battery electrolyte level, fuel level, upperstructure frame swing lock, control lock, travel speed and pre-heating.

Weights

With 3.70 m (12 ft 2 in) boom, 1.74 m (5 ft 7 in) arm, 450 mm (17.7 in) track shoes, 210 kg (463 lb) bucket, 75 kg (165 lb) operator and full fuel.

With 450 mm (17.7 in) pads (rubber) 6900 kg 15 210 lb

With 450 mm (17.7 in) pads (steel) 7000 kg 14 430 lb

With 600 mm (23.6 in) pads (steel) 7100 kg 15 650 lb

Arm

Length 1.74 m and 2.18 m 5 ft 7 in and 7 ft 2 in

Dozer blade

Width 2.25 m 7 ft 5 in

Height 0.46 m 18 in

Maximum height 0.37 m 14.5 in

Maximum depth 0.23 m 9 in

Tracks, Rollers and Idlers

Drive Sprocket Sprocket:

a standard value	35 mm	1.38 in
service limit.....	30 mm	1.18 in
b standard value	Ø 458.9 mm	18.08 in
service limit.....	Ø 453 mm	17.85 in
c standard value	Ø 513 mm	20.21 in
service limit.....	Ø 507 mm	19.98 in
d standard value	PDC 500 mm	19.7 in
service limit	—	
P standard value	135 mm	5.32 in
service limit	—	

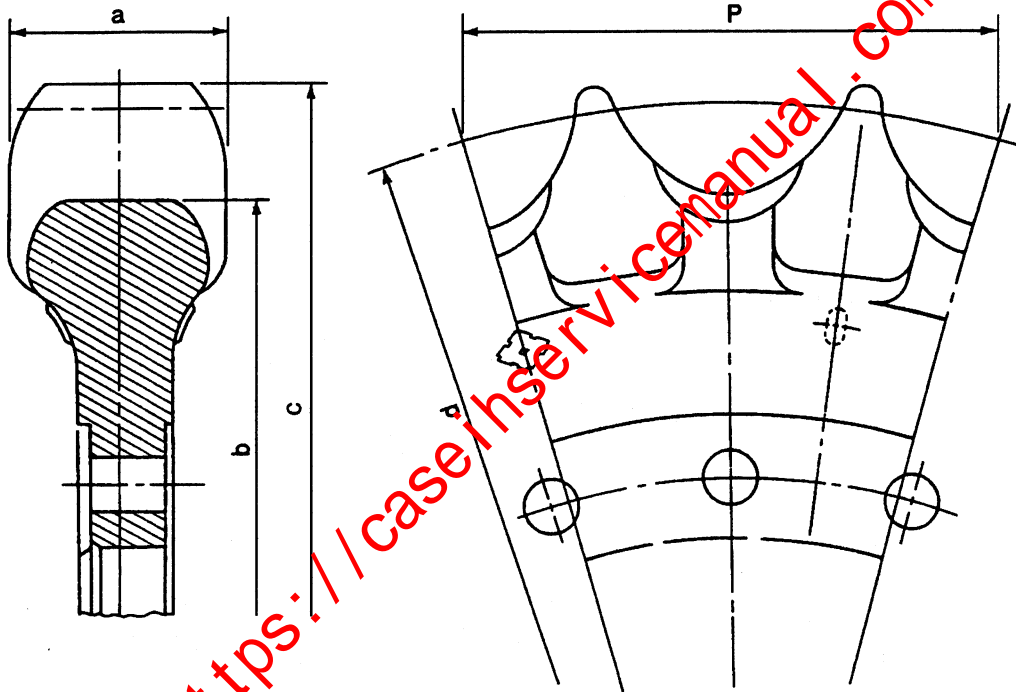

JS00065A

Track idler wheel
Track idler wheel:

a standard value	∅ 404 mm	∅ 15.92 in.
service limit	∅ 400 mm	∅ 15.76 in.
b standard value (for steelshoe).....	19.5 mm	0.77 in.
service limit	—	—
b standard value (for rubber shoe).....	28 mm	1.10 in.
service limite	—	—
c standard value	44 mm	1.73 in.
service limit	40 mm	1.58 in.
Shaft:		
d standard value	∅ 45 mm	1.77 in.
service limit	∅ 44 mm	1.73 in.
Bushing:		
d standard value	∅ 45 mm	1.77 in.
service limit	∅ 45.8 mm	1.80 in.
e standard value	40 mm	1.58 in.
service limit	39.6 mm	1.56 in.

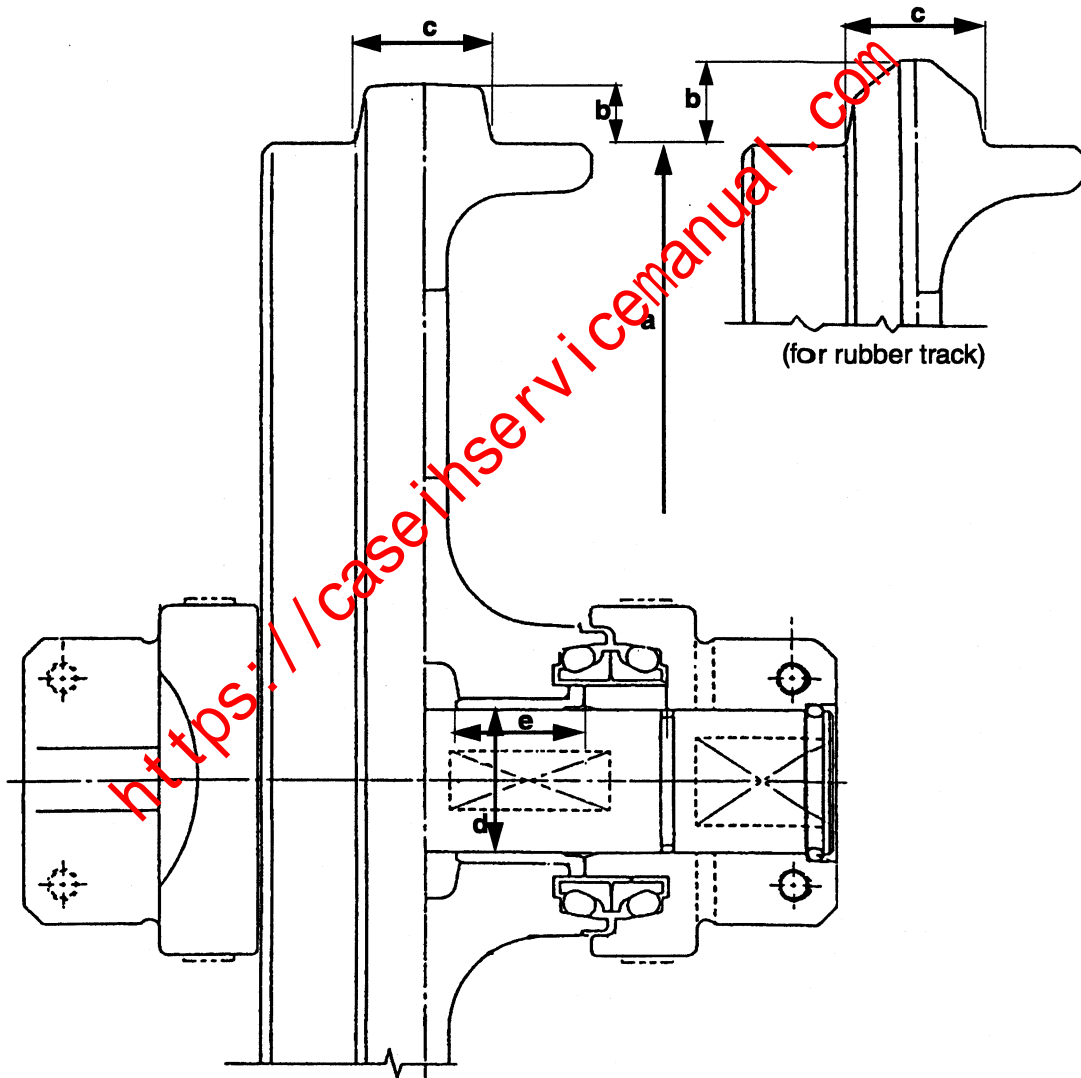

Track idler wheel

CS99A813

1002-10

Upper Roller

Upper Roller:

a standard value	Ø 90 mm	Ø 3.55 in.
service limit.....	Ø 82 mm	Ø 3.23 in.
b standard value	10 mm	0.39 in.
service limit	—	—
c standard value	44 mm	1.73 in.
service limit	—	—
Shaft:		
d standard value	Ø 32 mm	Ø 1.26 in.
service limit.....	Ø 31 mm	Ø 1.22 in.
Bushing:		
d standard value	Ø 32 mm	Ø 1.26 in.
service limit.....	Ø 32.6 mm	Ø 1.28 in.

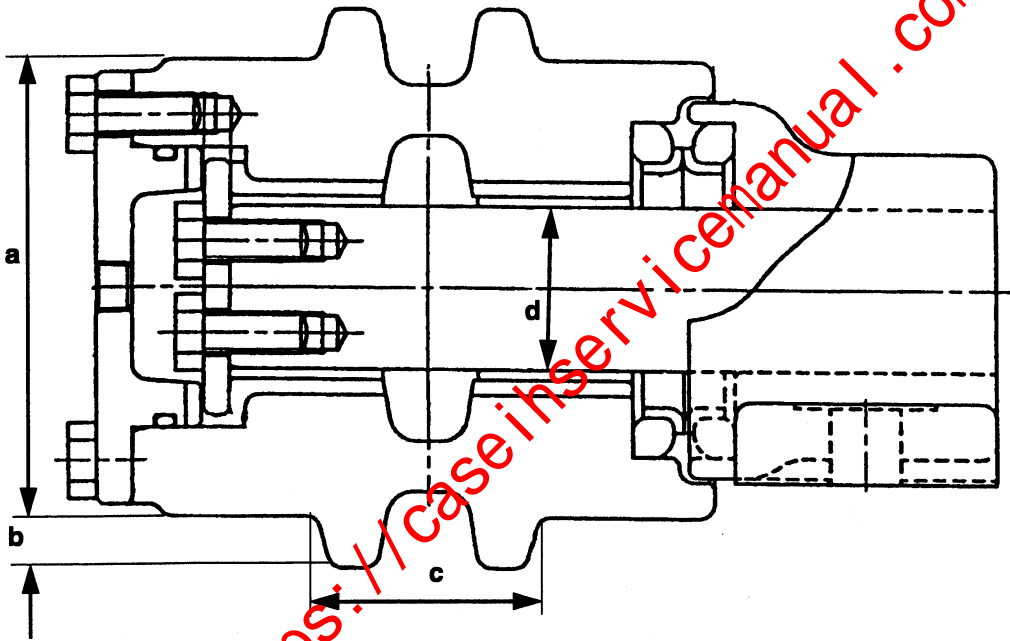

Upper Roller

CS99A814

Lower Roller (Inside)

Lower Roller (Inside):

a standard value	Ø 118 mm	Ø 4.65 in.
service limit	Ø 112 mm	Ø 4.41 in.
b standard value	13 mm	0.51 in.
service limit	—	—
c standard value	44 mm	1.73 in.
service limit	—	—

Shaft:

e standard value	Ø 42 mm	Ø 1.65 in.
service limit	Ø 41 mm	Ø 1.62 in.

Bushing:

e standard value	Ø 42 mm	Ø 1.65 in.
service limit	Ø 42.8 mm	Ø 1.69 in.

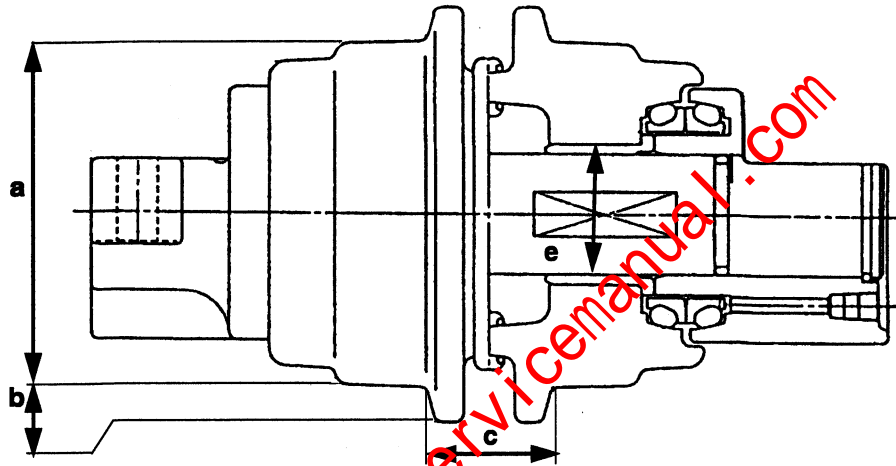

Lower Roller (Inside)

CS99A815

1002-12

Lower Roller (Outside)

Lower Roller:

a standard value	Ø 118 mm	Ø 4.65 in.
service limit.....	Ø 112 mm	Ø 4.41 in.
b standard value	13 mm	0.51 in.
service limit	—	—
d standard value	110 mm	4.33 in.
service limit	—	—

Shaft:

e standard value	Ø 42 mm	Ø 1.65 in.
service limit.....	Ø 41 mm	Ø 1.62 in.

Bushing:

e standard value	Ø 42 mm	Ø 1.65 in.
service limit.....	Ø 42.8 mm	Ø 1.69 in.

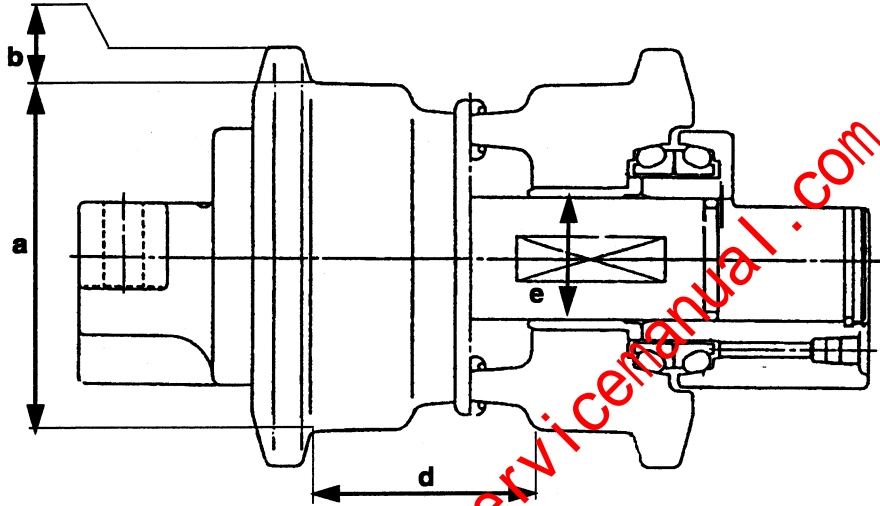

Lower Roller (Outside)

CS99A816

Track Shoe (Grouser Shoe)

Shoe Plate (450 mm) :

Link:

Master Bushing:

Master Pin:

Link Pitch:

Track Bushing:

Track Pin:

a standard value	24 mm	0.95 in.
service limit	18 mm	0.71 in.
b standard value	75 mm	2.96 in.
service limit	72.5 mm	2.86 in.
c standard value	105.6 mm	4.16 in.
service limit	100.6 mm	3.96 in.
d standard value	45 mm	1.77 in.
service limit	50 mm	1.97 in.
e standard value	Ø 41.15 mm	Ø 1.62 in.
service limit	Ø 40.15 mm	Ø 1.58 in.
f standard value	Ø 24.3 mm	Ø 0.96 in.
service limit	Ø 25 mm	Ø 0.99 in.
g standard value	Ø 23.8 mm	Ø 0.98 in.
service limit	Ø 23 mm	Ø 0.91 in.
h standard value	675 mm	26.60 in.
service limit	690 mm	27.19 in.
e' standard value	Ø 41.15 mm	Ø 1.62 in.
service limit	Ø 40.15 mm	Ø 1.58 in.
f' standard value	Ø 24.3 mm	Ø 0.96 in.
service limit	Ø 25 mm	Ø 0.99 in.
g' standard value	Ø 24 mm	Ø 0.95 in.
service limit	Ø 23 mm	Ø 0.91 in.

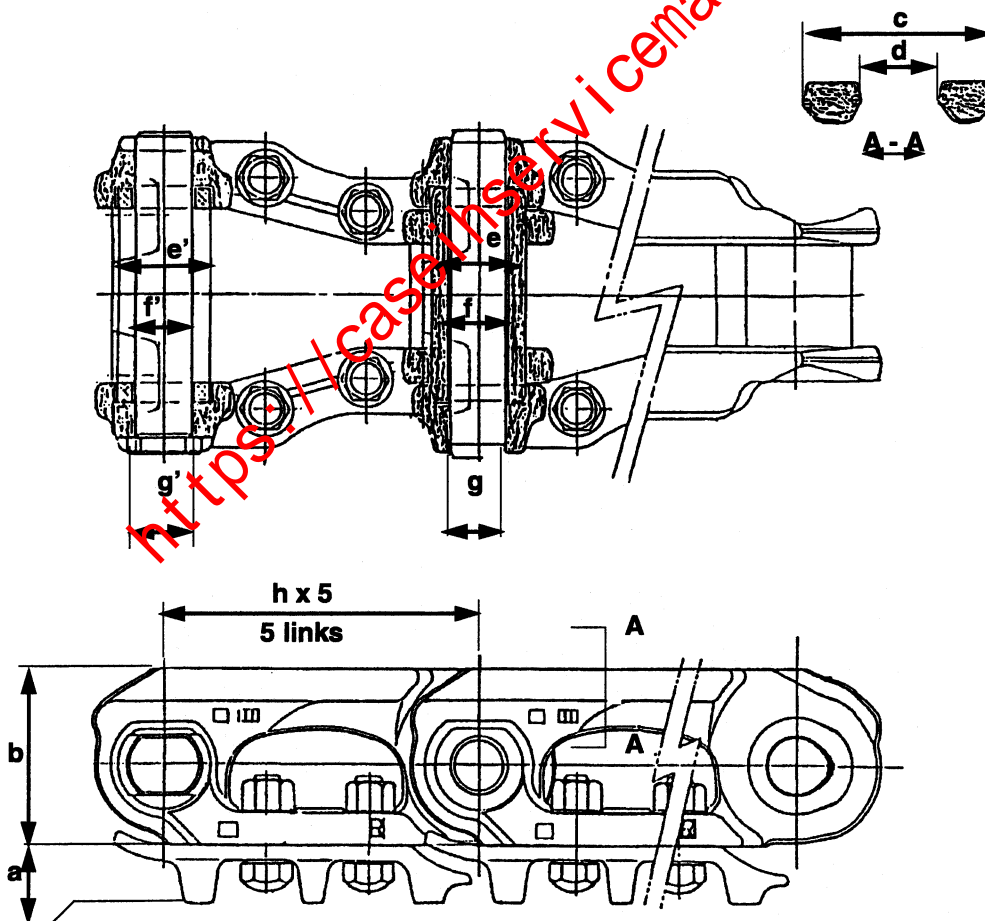

Track Shoe (Grouser Shoe)

CS99A817