

<https://caseihservicemanual.com>

W20F
Wheel Loader

SERVICE MANUAL

Part number 48096018A
2nd edition English
May 2018

© 2018 CNH Industrial Latin America LTDA. All Rights Reserved.

CASE
CONSTRUCTION



SERVICE MANUAL

W20F Standard model, with cab, Tier 3, made in Brazil
W20F Fertilizer model, with cab, Tier 3, made in Brazil

<https://caseihservicemanual.com>

Link Product / Engine

Product	Market Product	Engine
W20F Standard model, with cab, Tier 3, made in Brazil	Australia New Zealand	F4GE9684T*J601
W20F Standard model, with cab, Tier 3, made in Brazil	North America	F4GE9684T*J601
W20F Standard model, with cab, Tier 3, made in Brazil	Europe	F4GE9684T*J601
W20F Standard model, with cab, Tier 3, made in Brazil	Asia Pacific	F4GE9684T*J601
W20F Standard model, with cab, Tier 3, made in Brazil	Middle East Africa	F4GE9684T*J601
W20F Standard model, with cab, Tier 3, made in Brazil	Latin America	F4GE9684T*J601
W20F Fertilizer model, with cab, Tier 3, made in Brazil	Asia Pacific	F4GE9684T*J601
W20F Fertilizer model, with cab, Tier 3, made in Brazil	Australia New Zealand	F4GE9684T*J601
W20F Fertilizer model, with cab, Tier 3, made in Brazil	Europe	F4GE9684T*J601
W20F Fertilizer model, with cab, Tier 3, made in Brazil	Latin America	F4GE9684T*J601
W20F Fertilizer model, with cab, Tier 3, made in Brazil	North America	F4GE9684T*J601
W20F Fertilizer model, with cab, Tier 3, made in Brazil	Middle East Africa	F4GE9684T*J601

<https://caseihservicemanual.com>

Contents

INTRODUCTION

Engine.....	10
[10.001] Engine and crankcase	10.1
[10.102] Pan and covers	10.2
[10.202] Air cleaners and lines	10.3
[10.216] Fuel tanks	10.4
[10.400] Engine cooling system	10.5
Main gearbox and drive	14
[14.100] Main gearbox and drive	14.1
Transmission.....	21
[21.114] Mechanical transmission	21.1
[21.113] Powershift transmission	21.2
[21.135] Powershift transmission external controls.....	21.3
[21.155] Powershift transmission internal components.....	21.4
Front axle system	25
[25.100] Powered front axle.....	25.1
[25.102] Front bevel gear set and differential	25.2
[25.108] Final drive hub, steering knuckles, and shafts	25.3
Rear axle system.....	27
[27.100] Powered rear axle.....	27.1
[27.106] Rear bevel gear set and differential	27.2
[27.120] Planetary and final drives	27.3
[27.124] Final drive hub, steering knuckles, and shafts	27.4
Hydrostatic drive.....	29
[29.204] Reservoir, cooler, and lines	29.1
[29.218] Pump and motor components.....	29.2

Brakes and controls	33
[33.202] Hydraulic service brakes	33.1
[33.110] Parking brake or parking lock	33.2
Hydraulic systems	35
[35.000] Hydraulic systems.....	35.1
[35.102] Pump control valves.....	35.2
[35.106] Variable displacement pump	35.3
[35.300] Reservoir, cooler, and filters.....	35.4
[35.359] Main control valve.....	35.5
[35.204] Remote control valves	35.6
[35.701] Front loader arm hydraulic system	35.7
[35.736] Boom hydraulic system	35.8
Frames and ballasting	39
[39.100] Frame	39.1
Steering	41
[41.200] Hydraulic control components	41.1
[41.206] Pump	41.2
[41.216] Cylinders	41.3
[41.101] Steering control	41.4
Wheels	44
[44.520] Rear wheels	44.1
[44.511] Front wheels.....	44.2
Cab climate control	50
[50.104] Ventilation	50.1
[50.200] Air conditioning	50.2
Electrical systems	55
[55.000] Electrical system	55.1

[55.525] Cab engine controls	55.2
[55.201] Engine starting system	55.3
[55.301] Alternator	55.4
[55.302] Battery	55.5
[55.610] Ground speed control	55.6
[55.050] Heating, Ventilation, and Air-Conditioning (HVAC) control system	55.7
[55.100] Harnesses and connectors	55.8
[55.404] External lighting	55.9
[55.408] Warning indicators, alarms, and instruments	55.10
Booms, dippers, and buckets	84
[84.100] Bucket	84.1
Platform, cab, bodywork, and decals	90
[90.114] Operator protections	90.1
[90.151] Cab interior	90.2

<https://caseih.servicemanual.com>

<https://caseihservicemanual.com>



INTRODUCTION

<https://caseihservicemanual.com>

Contents

INTRODUCTION

Foreword - Important notice regarding equipment servicing	3
Foreword - How to use and navigate through this manual	4
Safety rules	9
Safety rules (Signal word definitions)	10
Safety rules	11
Safety rules	13
Safety rules	15
Safety rules (Weld works)	19
Safety rules - (Machine service)	21
Torque	29
Torque - Standard torque data for hydraulics	33
Basic instructions - Shop and assembly	35
Basic instructions (Daily inspection)	37
General specifications	38
Overall dimensions	42
Operating weights	46
Conversion factors	47
Consumables	59
Hydraulic contamination	61
Product identification (Sides of the machine)	62
Part identification - (Identification plates)	63
Part identification (Security lock, transport and service)	65
Part identification (Access doors, filling locations, and filters)	66
Product overview - (Machine Components)	73

Foreword - Important notice regarding equipment servicing

All repair and maintenance work listed in this manual must be carried out only by qualified dealership personnel, strictly complying with the instructions given, and using, whenever possible, the special tools.

Anyone who performs repair and maintenance operations without complying with the procedures provided herein shall be responsible for any subsequent damages.

The manufacturer and all the organizations of its distribution chain, including - without limitation - national, regional, or local dealers, reject any responsibility for damages caused by parts and/or components not approved by the manufacturer, including those used for the servicing or repair of the product manufactured or marketed by the manufacturer. In any case, no warranty is given or attributed on the product manufactured or marketed by the manufacturer in case of damages caused by parts and/or components not approved by the manufacturer.

The manufacturer reserves the right to make improvements in design and changes in specifications at any time without notice and without incurring any obligation to install them on units previously sold. Specifications, descriptions, and illustrative material herein are as accurate as known at time of publication but are subject to change without notice.

In case of questions, refer to your CASE CONSTRUCTION Sales and Service Networks.

<https://caseihservicemanual.com>

Foreword - How to use and navigate through this manual

This manual has been produced by a new technical information system. This new system is designed to deliver technical information electronically through web delivery (eTIM), DVD, and paper manuals. A coding system called SAP has been developed to link the technical information to other Product Support functions, e.g., Warranty.

Technical information is written to support the maintenance and service of the functions or systems on a customer's machine. When a customer has a concern on their machine it is usually because a function or system on their machine is not working at all, is not working efficiently, or is not responding correctly to their commands. When you refer to the technical information in this manual to resolve that customer's concern, you will find all the information classified using the SAP coding, according to the functions or systems on that machine. Once you have located the technical information for that function or system, you will then find all the mechanical, electrical or hydraulic devices, components, assemblies, and sub assemblies for that function or system. You will also find all the types of information that have been written for that function or system: the technical data (specifications), the functional data (how it works), the diagnostic data (fault codes and troubleshooting), and the service data (remove, install adjust, etc.).

By integrating SAP coding into technical information, you will be able to search and retrieve just the right piece of technical information you need to resolve that customer's concern on his machine. This is made possible by attaching 3 categories to each piece of technical information during the authoring process.

The first category is the Location, the second category is the Information Type and the third category is the Product:

- LOCATION - the component or function on the machine, that the piece of technical information is going to describe (e.g., Fuel tank).
- INFORMATION TYPE - the piece of technical information that has been written for a particular component or function on the machine (e.g., Capacity would be a type of Technical Data describing the amount of fuel held by the fuel tank).
- PRODUCT - the model for which the piece of technical information is written.

Every piece of technical information will have those three categories attached to it. You will be able to use any combination of those categories to find the right piece of technical information you need to resolve that customer's concern on their machine.

That information could be:

- the procedure for how to remove the cylinder head
- a table of specifications for a hydraulic pump
- a fault code
- a troubleshooting table
- a special tool

Manual content

This manual is divided into Sections. Each Section is then divided into Chapters. Contents pages are included at the beginning of the manual, then inside every Section and inside every Chapter. An alphabetical Index is included at the end of each Chapter. Page number references are included for every piece of technical information listed in the Chapter Contents or Chapter Index.

Each Chapter is divided into four Information types:

- Technical Data (specifications) for all the mechanical, electrical or hydraulic devices, components, assemblies or sub-assemblies.
- Functional Data (how it works) for all the mechanical, electrical or hydraulic devices, components, assemblies or sub-assemblies.
- Diagnostic Data (fault codes, electrical and hydraulic troubleshooting) for all the mechanical, electrical or hydraulic devices, components, assemblies or sub-assemblies.
- Service Data (remove disassemble, assemble, install) for all the mechanical, electrical or hydraulic devices, components, assemblies or sub-assemblies.

Sections

Sections are grouped according to the main functions or a systems on the machine. Each Section is identified by a number (00, 35, 55, etc.). The Sections included in the manual will depend on the type and function of the machine that the manual is written for. Each Section has a Contents page listed in alphabetic/numeric order. This table illustrates which Sections could be included in a manual for a particular product.

SECTION	PRODUCT					
	Tractors					
	Vehicles with working arms: backhoes, excavators, skid steers,					
	Combines, forage harvesters, balers,					
	Seeding, planting, floating, spraying equipment,					
Mounted equipment and tools,						
00 - Maintenance	X	X	X	X	X	
05 - Machine completion and equipment	X	X	X	X	X	
10 - Engine	X	X	X	X		
14 - Main gearbox and drive	X	X	X	X		
18 - Clutch	X	X	X			
21 - Transmission	X	X	X	X		
23 - Four wheel drive (4WD) system	X	X	X	X		
25 - Front axle system	X	X	X	X		
27 - Rear axle system	X	X	X	X		
29 - Hydrostatic drive	X	X	X	X		
31 - Power Take-Off (PTO)	X		X			
33 - Brakes and controls	X	X	X	X		
35 - Hydraulic systems	X	X	X	X		
36 - Pneumatic system	X	X	X	X		
37 - Hitches, drawbars and implement couplings	X		X	X		
39 - Frames and ballasting	X	X	X	X	X	
41 - Steering	X	X	X	X		
44 - Wheels	X	X	X	X		
46 - Steering clutches						
48 - Tracks and track suspension	X	X	X			
50 - Cab climate control	X	X	X	X		
55 - Electrical systems	X	X	X	X	X	
56 - Grape harvester shaking						
58 - Attachments/headers			X			
60 - Product feeding			X			

INTRODUCTION

61 - Metering system				X	
62 - Pressing - Bale formation			X		
63 - Chemical applicators				X	
64 - Chopping			X		
66 - Threshing			X		
68 - Tying/Wrapping/Twisting			X		
69 - Bale wagons					
70 - Ejection			X		
71 - Lubrication system	X	X	X	X	X
72 - Separation			X		
73 - Residue handling			X		
74 - Cleaning			X		
75 - Soil preparation/Finishing					
76 - Secondary cleaning / Destemmer					
77 - Seeding				X	
78 - Spraying				X	
79 - Planting				X	
80 - Crop storage / Unloading			X		
82 - Front loader and bucket	X	X			
83 - Telescopic single arm	X	X			
84 - Booms, dippers and buckets	X	X			
86 - Dozer blade and arm	X	X			
88 - Accessories	X	X	X	X	X
89 - Tools	X	X	X	X	X
90 - Platform, cab, bodywork and decals	X	X	X	X	X

<https://caseihservicemanual.com>

Chapters

Each Chapter is identified by a number e.g. Engine - Engine and crankcase - 10.001. The first number is identical to the Section number i.e. Chapter 10.001 is inside Section 10, Engine. The second number is representative of the Chapter contained within the Section.

CONTENTS

The Chapter Contents lists all the technical data (specifications), functional data (how it works), diagnostic data (fault codes and troubleshooting), and service data (remove, install, adjust, etc.), that have been written in that Chapter for that function or system on the machine.

Contents

	ENGINE	
	ENGINE - Engine and crankcase – 10.001	
TECHNICAL DATA		
ENGINE - Engine and crankcase - General specification (10.001 - D.40.A.10)		4
FUNCTIONAL DATA		
ENGINE - Engine and crankcase - Dynamic description (10.001 - C.30.A.10)		6
SERVICE		
ENGINE - Engine and crankcase - Remove (10.001 -F.10.A.10)		8
DIAGNOSTIC		
ENGINE - Engine and crankcase - Troubleshooting (10.001 - G.40.A.10)		10

INDEX

The Chapter Index lists in alphabetical order all the types of information (called information units) that have been written in that Chapter for that function or system on the machine.

Index

	ENGINE - 10	
	ENGINE	
ENGINE - Engine and crankcase - Dynamic description (10.001 - C.30.A.10)		6
ENGINE - Engine and crankcase - General specification (10.001 - D.40.A.10)		4
ENGINE - Engine and crankcase - Remove (10.001 -F.10.A.10)		8
ENGINE - Engine and crankcase - Troubleshooting (10.001 - G.40.A.10)		10

Information units and information search

Each chapter is composed of information units. Each information unit has the SAP code shown in parentheses. This indicates the function and type of information in that information unit. Each information unit has a page reference within that Chapter. The information units provide a quick and easy way to find just the right piece of technical information you are looking for.

Example information unit	Engine block cover - Front – Remove (10.102.AP.01 - F.10.A.10)					
Information Unit SAP code	10	102	AK	01	F	10.A.10
SAP code classification	Engine	Pan and covers	Engine block cover	Front	Service data	Remove

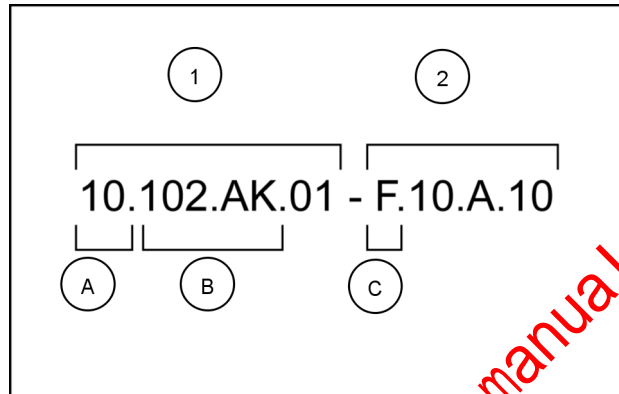

NHIL12GEN0070A 1

Navigate to the correct information unit you are searching for by identifying the function and information type from the SAP code.

- **(1)** Location and **(2)** Information type.
- **(A)** corresponds to the sections of the service manual.
- **(B)** corresponds to the chapters of the service manual. After **(B)** there may be some additional information. In this case it shows “.01”, which represents the “Front” block cover. These options may be front/rear, left/right, hydraulic/mechanical etc.
- **(C)** corresponds to the type of information listed in the chapter contents: Technical Data, Functional Data, Diagnostic, or Service.
- **(A)** and **(B)** are also shown in the page numbering on the page footer.
- THE REST OF THE CODING IS NOT LISTED IN ALPHANUMERIC ORDER IN THIS MANUAL.
- You will find a table of contents at the beginning and end of each section and chapter. You will find an alphabetical index at the end of each chapter.
- By referring to **(A)**, **(B)** and **(C)** of the coding, you can follow the contents or index (page numbers) and quickly find the information you are looking for.

Page header and footer

The page header will contain the following references:

- Section and Chapter description

The page footer will contain the following references:

- Publication number for that Manual.
- Version reference for that publication.
- Publication date
- Section, chapter, and page reference e.g. 10.102 / 9

Safety rules

Ecology and environment

Soil, air and water are vital factors of life in general. Disposing of waste improperly represents a danger for the environment.

NOTE: Some recommendations must be followed:

- Obtain information about the correct methods to recycle or dispose of waste from local authorities, collection centers or your dealer.
- Do not dispose of waste onto the ground, into drains, or in water beds.
- Do not fill reservoirs using cans or inappropriate pressurized fluid delivery systems, as they may cause considerable spillage.
- Use sealed containers when draining the fluids. Do not use containers for food or beverages which may induce ingestion.
- The air conditioning system is under pressure, and contains gases that should not be released into the atmosphere. Do not disconnect or remove any component from the pressure line of the air conditioning system. If you need repairs to the air conditioning system, contact a dealer.
- Immediately repair any leaks or defects in the machine's engine cooling and hydraulic systems.
- Generally avoid skin contact with any fuels, oils, fluids, acids, solvents, etc. Most of them contain substances which may be harmful to your health.
- Avoid spills when draining fluid. Store them safely until they can be disposed of properly in compliance with local legislation.
- Protect hoses and pipes during welding works, because the sparks generated during the welding work can damage them, allowing the fluid to leak.

Mandatory recycling

The battery is essentially composed of lead plates and sulfuric acid solution. Because the battery contains heavy metals such as lead, resolution 401 de 2008 of CONAMA orders that all used batteries must be returned to the battery dealer at the time of replacement. Do not dispose of the battery in the garbage. Points of sale are obliged to accept the return of your used battery, and to store it in a suitable place and return it to the manufacturer for recycling.

Improper disposal of batteries can contaminate the soil, groundwater and waterways. Consumption of contaminated water can cause serious health risks. Contact of the acid solution with the skin or eyes can cause serious injury and blindness. In case of accidental contact with the eyes or skin, immediately wash with running water and seek emergency medical care.



CUIL13TRO0091AA 1

Safety rules (Signal word definitions)

Personal Safety



This is the safety alert symbol. It is used to alert you to potential personal injury hazards. Obey all safety messages that follow this symbol to avoid possible death or injury.

Throughout this manual and on machine safety signs, you will find the signal words DANGER, WARNING, and CAUTION followed by special instructions. These precautions are intended for your personal safety and for all those involved in the work activity during operation of the machine.

Read and understand all the safety messages in this manual before you operate or service the machine.

DANGER:

 Indicates an immediate danger that, if not avoided, will cause death or serious injury. The color associated with Danger is RED.

WARNING:

 Indicates a potential danger that, if not avoided, will cause serious injury. The color associated with Warning is ORANGE.

CAUTION:

 Indicates a potential danger that, if not avoided, can cause minor or moderate injury. ORANGE also alerts the operator to unsafe practices. The color associated with Caution is YELLOW.

FAILURE TO FOLLOW DANGER, WARNING AND CAUTION MESSAGES COULD RESULT IN DEATH OR SERIOUS INJURY.

Machine safety

NOTICE: Indicates a situation that, if not avoided, could result in machine or property damage. The color associated with Notice is BLUE.

Throughout this manual you will find the signal word Notice followed by special instructions to prevent machine or property damage. The word Notice is used to address practices not related to personal safety.

Information

NOTE: Indicates additional information which clarifies steps, procedures, or other information in this manual.

Throughout this manual you will find the word NOTE followed by additional information about a step, procedure or other information in the manual. The word NOTE is not intended to address personal safety or property damage.

Safety rules

Standard safety precautions

Be informed and notify personnel of the laws in force regulating safety, and provide documentation available for consultation.

- Keep working areas as clean as possible.
- Ensure that working areas are provided with emergency boxes. They must be clearly visible and always contain adequate sanitary equipment.
- Fire extinguishers must be properly identified and always be clear of obstructions. Their efficiency must be checked on a regular basis and personnel must be trained on proper interventions and priorities.
- Keep all emergency exits free of obstructions and clearly marked.
- Smoking in working areas subject to fire danger must be strictly prohibited.

Prevention of injury

- Wear suitable work attire and safety glasses with no jewelry such as rings and chains when working close to engines and equipment in motion.
- Wear safety gloves and goggles when performing the following operations:
 - Topping off or changing lubrication oils.
 - Using compressed air or liquids at a pressure greater than **2 bar (29 psi)**.
- Wear a safety helmet when working close to hanging loads or equipment working at head level.
- Always wear safety shoes and fitting clothes.
- Use protection cream for hands.
- Change wet clothes as soon as possible.
- In the presence of voltages exceeding **48 – 60 V**, verify the efficiency of the ground and mass electrical connections. Ensure that hands and feet are dry and use isolating foot boards. Workers should be properly trained to work with electricity.
- Do not smoke or start an open flame close to batteries and any fuel material.
- Place soiled rags with oil, diesel fuel or solvents in specially provided anti-fire containers.
- Do not use any tool or equipment for any use other than what it was originally intended for. Serious injury may occur.
- If running an engine indoors, make sure there is a sufficient exhaust fan in use to eliminate exhaust fumes.

During maintenance

- Never open the filler cap of the cooling system when the engine is hot. High temperature liquid at operating pressure could result in serious danger and risk of burn. Wait until the temperature decreases under **50 °C (122 °F)**.
- Never add coolant to an overheated engine and use only appropriate liquids.
- Always work when the engine is turned off. Certain circumstances require maintenance on a running engine. Be aware of all the risks involved with such an operation.
- Always use adequate and safe containers for engine fluids and used oil.
- Keep engine clean of any spilled fluids such as oil, diesel fuel, and or chemical solvents.
- Use of solvents or detergents during maintenance may emit toxic vapors. Always keep working areas aerated. Wear a safety mask if necessary.
- Do not leave soiled rags that may contain any flammable substances close to the engine.
- Always use caution when starting an engine after any work has been performed. Be prepared to cut off intake air in case of engine runaway.
- Never disconnect the batteries while the engine is running.
- Disconnect the batteries prior to performing any work on the equipment.

- Disconnect the batteries to place a load on them with a load tester.
- After any work is performed, verify that the battery clamp polarity is correct and that the clamps are tight and safe from accidental short circuit and oxidation.
- Before disconnecting any pipelines (pneumatic, hydraulic, fuel pipes, etc.), verify that all pressure has been released. Take all necessary precautions bleeding and draining residual pressure. Always wear the proper safety equipment.
- Do not alter the lengths of any wires.
- Do not connect any electronic service tool to the engine electrical equipment unless specifically approved by CASE CONSTRUCTION.
- Do not modify the fuel system or hydraulic system unless approved by CASE CONSTRUCTION. Any unauthorized modification will compromise warranty assistance and may affect engine operation and life span.

For engine equipped with an electronic control unit

- Do not weld on any part of the equipment without removing the control unit.
- Remove the in case of work requiring heating over **80 °C (176 °F)**.
- Do not paint the components and the electronic connections.
- Do not alter any data filed in the electronic control unit driving the engine. Any manipulation or alteration of electronic components will void engine warranty assistance and may affect the correct working order and life span of the engine.

Respect of the Environment

- Respect of the environment should be of primary importance. Take all necessary precautions to ensure personnel's safety and health.
- Inform the personnel of the laws regarding the dispensing of used engine fluids.
- Handle batteries with care, storing them in a well ventilated environment and within anti-acid container.

<https://caseinstruments.com>

Safety rules

General safety regulations

General Aspects

- Strictly follow repair and maintenance procedures.
- Do not wear rings, wrist watches, jewelry, accessories, unbuttoned items of clothing, unsecured clothing like ties, torn clothing, scarves, or open jackets or shirts with open zippers that could get caught in moving parts. Use approved safety clothing, such as anti-slip footwear, sleeves, protective goggles, helmets, etc.
- Wear safety goggles with side shields when cleaning parts using compressed air.
- Worn or damaged cables and chains are not reliable. Do not use these elements in lifting or towing operations.
- Use regulation safety equipment, such as approved eye protection, helmets, clothes, sleeves, and special footwear whenever you are welding. All individuals near the welding process must use regulation eye protection. Never look at the welding arc without using suitable eye protection.
- Never perform any repairs on the machine if there is someone in the operator seat, except when the person is a qualified operator who is helping with the service to be performed.
- Never operate the machine or use accessories from a place other than the operator seat or next to the machine when operating the fender switches.
- Never perform any operations on the machine with the engine running, except when specifically instructed to do so. Shut down the engine and release all the pressure from the hydraulic circuits before removing covers, cases, valves, etc.
- You must conduct all repair and maintenance operations with the utmost care and attention.
- Disconnect the batteries and put warning labels on all of the controls to warn that the machine is being repaired. Lock the machine and all the equipment that you remove.
- Never check or fill the fuel tank or batteries or use starting fluid when you are smoking or near a naked flame, because these fluids are flammable.
- The fuel filling gun must remain in contact with the filler neck. Maintain the contact until the fuel stops flowing into the tank in order to avoid sparks caused by static electricity build-up.
- To transport a faulty machine, use a trailer or a low loader platform trolley, if available.
- To load and unload the machine from the mode of transportation, choose a flat area that offers firm support for the wheels of the truck or trailer. Securely fasten the machine to the platform of the trailer or truck, in accordance with the transporter's requirements.
- Always use hoist mechanisms with an appropriate capacity for lifting or moving heavy components.
- Chains must always be securely fastened. The fastening device must have sufficient capacity to support the intended load. It is prohibited for bystanders to be near the fastening position.
- The work area must always be clean and dry. Clean it immediately if any water or oil is spilled.
- Never use gasoline, diesel, or other flammable liquids for cleaning. Use only non-toxic solvents.
- Do not allow cloths soaked with oil or grease to accumulate because they can cause a fire risk. Always keep these cloths in a metal container.

Starting

- Never start the engine in enclosed spaces that are not equipped with a suitable exhaust system or gas-extraction system.
- Never bring your head, body, arms, legs, feet, hands, or fingers close to fans or rotating belts.

Engine

- Always loosen the radiator cap slowly before removing it, in order to dissipate the system pressure. You must top up the coolant with the engine stopped.
- Do not fill up the fuel tank when the engine is running.
- Never adjust the fuel injection pump when the machine is in motion.

- Never lubricate the machine when the engine is running.

Electrical systems

- If it is necessary to use auxiliary batteries, you must connect the cables on both sides as follows: (+) to (+) and (-) to (-). Avoid causing the terminals to short circuit. The gas that the batteries release is highly flammable. During charging, leave the battery compartment open to improve ventilation. Avoid sparks and naked flames near the battery. Do not smoke.
- Do not charge the batteries in enclosed spaces.
- Always disconnect the batteries before carrying out any type of servicing on the electrical system.

Hydraulic system

- A little fluid coming out of a small bore could be almost invisible, but strong enough to penetrate the skin. For this reason, never use your hands to check for leaks. Instead, use a piece of cardboard or wood. If any fluid penetrates your skin, seek medical assistance immediately. Failure to seek immediate medical assistance could result in serious infections or dermatitis.
- Always read the system pressure using suitable gauges.

Wheels and tires

- Make sure that the tires are correctly inflated at the pressure specified by the manufacturer. Inspect the rims and tires regularly for any damage.
- Remain next to the tire when filling it with air.
- Only check the pressure when the platform is unloaded and the tires are cold, in order to prevent inaccurate readings caused by overpressure.
- Never cut or weld a rim with a full tire fitted.
- To remove the wheels, lock both the front and rear wheels of the machine. Lift the machine. Install stable and secure supports under the machine, as per the legislation in force.
- Deflate the tire before removing any objects that may be caught in the tire tread.
- Never inflate tires using flammable gases, as they could cause explosions and injure bystanders.

Remove and install

- Lift and handle all heavy components using hoist devices of appropriate capacity. You must suspend the parts using suitable hooks and slings. Use the hoist eyes provided for this purpose. Be careful if there are any bystanders near the hoisted load.

Safety rules

Health and safety precautions

Many of the procedures involved in machine maintenance and repair services involve physical hazards and other health risks. This section lists some of these hazardous procedures and the materials and equipment associated with them.

Acids and alkalis

Avoid splashing into your eyes and nose, or onto your skin and clothing. Wear suitable sleeves and protective goggles. Irritate and corrode the skin, eyes, nose, and throat. Causes burns. Do not inhale the fumes.

Adhesives and sealants

These are highly flammable. You must store them in no smoking areas. Use applicators when possible or secondary containers. The containers must be labeled.

Resin-based adhesives/sealants

Skin contact could result in irritation, dermatitis, and the absorption of toxic or harmful chemicals through the skin. Splashes could cause eye injuries. Ensure that there is adequate ventilation and avoid contact with the skin and the eyes. Follow the manufacturer's instructions.

Ensure that there is adequate ventilation as volatile harmful or toxic chemicals may be released.

Anti-freeze

These are highly flammable. You must store them in no smoking areas.

Anti-freeze can be absorbed through the skin in toxic or harmful quantities. Ingesting anti-freeze can cause death and you must seek medical assistance immediately.

Chemicals – General

You must always take care when using and handling chemicals such as solvents, sealants, adhesives, paints, foam resins, battery acids, anti-freeze, brake fluid, oils and greases. They may be harmful, toxic, corrosive, irritant, or highly flammable. They may also emit hazardous fumes or dust.

Do

Remove chemicals from skin and clothing as soon as possible after contact. Change very dirty clothes and make provision for cleaning them.

Read and strictly adhere to the safety recommendations on the chemical containers.

When working with chemicals, wash before breaks, and before eating, smoking, drinking, or using the bathroom. Keep work areas clean, organized, and free of spillages. Store according to local and national legislation. Keep chemicals out of the reach of children.

Do not

Do not mix chemicals, except in accordance with the manufacturer's instructions. Some substances could form other chemical substances that are toxic or harmful, emit toxic or harmful fumes, or become explosive after mixing. Do not spray chemicals, especially solvent-based chemicals, in enclosed spaces.

Do not apply heat or flames to chemicals, except in accordance with the manufacturer's instructions. Some are highly flammable or could release toxic or harmful fumes.

Do not leave containers open. The fumes emitted could accumulate in toxic, harmful, or explosive concentrations. Some fumes are heavier than air and will accumulate in confined areas, trenches, etc. Do not put chemicals in unmarked containers.

Do not clean your hands or clothes with chemicals. Chemicals, particularly solvents and fuels, dry out the skin and can cause irritation and dermatitis. Some can be absorbed through the skin in toxic or harmful quantities.

Do not use empty containers to store other chemicals, except when they have been cleaned under supervision. Do not attempt to sniff or inhale chemicals. Rapid exposure to high concentrations of fumes can be toxic or harmful.

Anti-corrosive protective material

These materials are varied and you must follow the manufacturers' instructions. They may contain solvents, resins, petroleum derivatives, etc. You must avoid contact with the skin and the eyes. You must carry out spraying with adequate ventilation and never in enclosed spaces.

Post

Dust, powders, or clouds may be irritant, harmful, or toxic. Avoid inhaling the chemical powders or dusts that result from dry abrasion services. Use respiratory protection if ventilation is not adequate.

Electric shock

Electric shocks result from the use of faulty electrical equipment or from incorrect use.

You must keep electrical equipment in good condition and test it frequently.

Electrical equipment must be protected by a fuse with an appropriate nominal capacity.

Use low-voltage equipment (**110 volt**) for work lights and inspection lights wherever possible. Use pneumatic equipment instead of electrical equipment wherever possible.

In the event of electrocution:

- Turn off the electricity before approaching the victim.
- If that is not possible, push or pull the victim away from the source of the electricity using a dry, non-conductive material.
- If you have been trained, start giving first aid.
- Seek medical assistance.

Exhaust fumes

These fumes contain asphyxiating, toxic or harmful chemical substances. You must only run engines in adequate extraction or general ventilation conditions, and never in enclosed spaces.

Fiber insulation

The fibrous nature of cut surfaces and edges can cause skin irritation. In general, the effect is physical and not chemical. You must take precautions to avoid excessive skin contact. Take care when organizing your work methods. Wear sleeves.

Fire

Many materials relating to vehicle repair are highly flammable. Some release toxic or harmful fumes when burned.

Scrupulously observe the fire prevention safety recommendations when storing and handling flammable materials or solvents, particularly in the vicinity of electrical equipment or welding processes.

Before using any electrical or welding equipment, ensure that there is no risk of fire. Always have an appropriate fire extinguisher nearby when using welding or heating equipment.

Foams – Polyurethane

See fire. Used for soundproofing. Cured foams used in seat cushions and finishes. Follow the manufacturer's instructions.

Components that have not reacted are irritants and could be harmful to the eyes and the skin. Wear sleeves and protective goggles. Individuals with chronic respiratory illnesses, asthma, bronchial problems, or a history of allergic illnesses must not work with or be in proximity to uncured materials.

Components, fumes, and aerosol clouds can cause irritation and sensitization reactions, and may be toxic or harmful. You must apply these materials with adequate respiratory protection and adequate ventilation. Do not remove the respirator when you have finished spraying. Keep the respirator on until the fumes and clouds disperse.

Burning uncured components and cured foams can generate toxic and harmful fumes. Do not permit smoking, the presence of naked flames, or the use of electrical equipment during the application of foam, and until the fumes/clouds have dispersed. The hot cutting of cured or partially cured foam must be performed in an environment with a ventilation system with extraction.

Kerosene (Paraffin)

Ingesting kerosene can cause irritation to the mouth and throat. The greatest danger from ingesting kerosene is the possibility of breathing it into the lungs. Liquid contact dries the skin and can cause irritation or dermatitis. Splashes on the skin and in the eyes cause mild irritation.

Avoid contact with the eyes and the skin as far as possible and ensure that there is adequate ventilation.

Fuel oil (diesel fuel)

When the quantities are large or the exposure period is long, skin contact with fuel oils with a high boiling point can cause serious skin diseases, including skin cancer.

Gas cylinders

See fire. In general, gases, such as oxygen, carbon dioxide, argon, and propane, are stored in cylinders with pressures of up to **140 bar (2000 lb/in²)**. You need to take sufficient care when handling them to prevent physical damage to the cylinders and the valve accessories. The content of each cylinder must be clearly identified with suitable labels.

You must store the cylinders in a well-ventilated room, protected from ice, rain, and direct sunlight. You must not store combustible gases near to oxygen cylinders.

Be careful to prevent leaks from the cylinders and the gas lines, and to avoid ignition sources. Only qualified personnel may perform services using the cylinders.

General workshop equipment and tools

You must keep all equipment and tools in good condition and you must use the correct safety equipment whenever necessary.

Never use tools or equipment for any purpose other than that for which they are intended. Never overload equipment such as hoists, jacks, chassis bases and axles, or hoisting slings. The damage caused by overloading does not always appear immediately and could cause a fatal accident the next time that the equipment is used.

Do not use faulty or damaged equipment or tools, particularly high-speed equipment, such as emery wheels. A damaged emery wheel can disintegrate suddenly and cause serious injury. Use protective goggles whenever you use equipment for grinding, cutting, polishing, or sandblasting.

Oil test equipment, lubrication test equipment, and high-pressure air test equipment, in accordance with local legislation

Always keep high-pressure equipment in good condition and carry out regular maintenance, particularly on connections and fittings. Never point a high-pressure nozzle at the skin as the fluid can cause serious injuries.