

# CX330, CX330NLC and CX350 Tier 3 Crawler Excavators

## Table of Contents

DIVISION/SECTION	SECTION N°	REFERENCE N°
<b>1 GENERAL INFORMATION</b>		
Safety, general information and standard torque data .....	1001	7-27691EN
General specifications and special torque setting.....	1002	9-94170EN
<b>2 ENGINE</b>		
Radiator and engine, removal and installation .....	2001	9-94830EN
Engine specifications .....	*	
Disassembly and assembly of the engine.....	*	
<b>3 FUEL SYSTEM</b>		
Fuel tank .....	3001	9-43471EN
Fuel engine system.....	*	
<b>4 ELECTRICAL SYSTEM</b>		
Electrical system, electrical and electronic troubleshooting.....	4001	9-94180EN
Inspection and maintenance of batteries and connecting a booster battery....	4002	9-43460EN
Main and engine electronic control boxes.....	4003	9-43451EN
<b>5 UNDERCARRIAGE</b>		
Removal and installation of tracks .....	5001	9-42910EN
Rollers.....	5003	9-42921EN
Sprocket.....	5004	9-36890EN
Idler wheel and tension shock absorber .....	5005	9-94790EN
<b>6 DRIVE TRAIN</b>		
Drive motor and final drive transmission removal and installation .....	6001	9-43141EN
Swing reduction gear, removal and installation.....	6003	9-43210EN
Swing reduction gear, disassembly and assembly.....	6004	9-43221EN
Travel reduction gear disassembly and assembly .....	6005	9-43151EN
<b>7 UNDERCARRIAGE HYDRAULICS</b>		
<b>8 UPPERSTRUCTURE HYDRAULICS</b>		
Depressurising and decontaminating the hydraulic system, use of the vacuum pump and bleeding the components .....	8000	9-43501EN
Specifications, troubleshooting, checks and hydraulic pressure settings.....	8001	9-94190EN
Hydraulic reservoir removal and installation .....	8002	9-43230EN
Main and pilot pumps, removal and installation .....	8003	9-94840EN
Main hydraulic control valve, removal and installation .....	8004	9-43261EN
Attachment cylinders, removal and installation .....	8005	9-43251EN
Hydraulic swivel, removal and installation.....	8006	9-43390EN
Pilot blocs, removal and installation .....	8007	9-43400EN
Swing motor, removal and installation.....	8008	9-43200EN
Main hydraulic pump, disassembly and assembly .....	8010	9-94850EN
Main hydraulic control valve, disassembly and assembly .....	8011	9-43551EN
Attachment cylinders, disassembly and assembly.....	8012	9-94760EN
Hand control levers, disassembly and assembly .....	8013	9-94630EN
Foot control levers, disassembly and assembly.....	8014	7-28301EN
Six-solenoid valves, disassembly and assembly.....	8015	9-43361EN
Caution valve, disassembly and assembly.....	8016	9-94770EN
Hydraulic swivel, disassembly and assembly.....	8018	9-43190EN
Swing motor, disassembly and assembly .....	8019	9-43441EN
Hydraulic functions.....	8020	9-94200EN
Travel hydraulic motor, disassembly and assembly.....	8021	9-43161EN
Hydraulic component functions.....	8030	9-94210EN

DIVISION/SECTION	SECTION N°	REFERENCE N°
<b>9 UPPERSTRUCTURE</b>		
Upperstructure, turntable and counterweight .....	9002	9-43411EN
Boom, dipper and bucket .....	9003	9-43421EN
Seat and seat belt .....	9004	9-40960EN
Cab and cab equipment .....	9005	9-94800EN
Air conditioning troubleshooting .....	9006	██████████
Air conditioning unit disassembly and assembly .....	9007	9-94640EN
Air conditioning servicing .....	9008	██████████
Air conditioning components .....	9009	██████████
Large format hydraulic schematic .....	Pocket	9-93960
Large format electrical schematic .....	Pocket	9-93970

\* Consult the Engine Service Manual

██████████ Sections to be distributed at a later date

NOTE: CNH Company reserves the right to make changes in the specification and design of the machine without prior notice and without incurring any obligation to modify units previously sold.

The description of the models shown in this manual has been made in accordance with the technical specifications known as of the date of design of this document.

<https://caseih.servicemanual.com>

# Section

# 1001

**SAFETY, GENERAL INFORMATION  
AND TORQUE SPECIFICATIONS**

<https://caseih.servicemanual.com>

## TABLE OF CONTENTS

GENERAL INFORMATION .....	3
SAFETY .....	4
STANDARD TORQUE DATA FOR CAP SCREWS AND NUTS.....	6



**WARNING** : *This symbol is used in this manual to indicate important safety messages. Whenever you see this symbol, carefully read the message that follows, as there is a risk of serious injury.*

<https://caseihservicemanual.com>

## GENERAL INFORMATION

### Cleaning

Clean all metal parts except bearings, in a suitable cleaning solvent or by steam cleaning. Do not use caustic soda for steam cleaning. After cleaning, dry and put oil on all parts. Clean oil passages with compressed air. Clean bearings in a suitable cleaning solvent, dry the bearings completely and put oil on the bearings.

### Inspection

Check all parts when the parts are disassembled. Replace all parts that have wear or damage. Small scoring or grooves can be removed with a hone or crocus cloth. Complete a visual inspection for indications of wear, pitting and the replacement of parts necessary to prevent early failures.

### Bearings

Check bearings for easy action. If bearings have a loose fit or rough action replace the bearing. Wash bearings with a suitable cleaning solvent and permit to air dry. DO NOT DRY BEARINGS WITH COMPRESSED AIR.

### Needle bearings

Before you press needle bearings in a bore always remove any metal protrusions in the bore or edge of the bore. Before you press bearings into position put petroleum jelly on the inside and outside diameter of the bearings.

### Gears

Check all gears for wear and damage. Replace gears that have wear or damage.

### Oil seals, O-rings and gaskets

Always install new oil seals, O-rings and gaskets. Put petroleum jelly on seals and O-rings.

### Shafts

Check all shafts that have wear or damage. Check the bearing and oil seal surfaces of the shafts for damage.

### Service parts

Always install genuine Case service parts. When ordering refer to the Parts Catalog for the correct part number of the genuine Case replacement items. Failures due to the use of other than genuine Case replacement parts are not covered by warranty.

### Lubrication

Only use the oils and lubricants specified in the Operator's or Service Manuals. Failures due to the use of non-specified oils and lubricants are not covered by warranty.

## SAFETY



*This symbol means ATTENTION! BECOME ALERT! YOUR SAFETY IS INVOLVED. The message that follows the symbol contains important information about safety. Carefully read the message. Make sure you fully understand the causes of possible injury or death.*

To prevent injury always follow the Warning, Caution and Danger notes in this section and throughout the manual.

Put the warning tag shown below on the key for the keyswitch when servicing or repairing the machine. One warning tag is supplied with each machine. Additional tags Part Number 331-4614 are available from your service parts supplier



**WARNING:** *Read the operator's manual to familiarize yourself with the correct control functions.*



**WARNING:** *Operate the machine and equipment controls from the seat position only. Any other method could result in serious injury.*



**WARNING:** *This is a one man machine, no riders allowed.*



**WARNING:** *Before starting engine, study Operator's Manual safety messages. Read all safety signs on machine. Clear the area of other persons. Learn and practice safe use of controls before operating.*

*It is your responsibility to understand and follow manufacturers instructions on machine operation, service and to observe pertinent laws and regulations. Operator's and Service Manuals may be obtained from your Case dealer.*



**WARNING:** *If you wear clothing that is too loose or do not use the correct safety equipment for your job, you can be injured. Always wear clothing that will not catch on objects. Extra safety equipment that can be required includes hard hat, safety shoes, ear protection, eye or face protection, heavy gloves and reflector clothing.*



**WARNING:** *When working in the area of the fan belt with the engine running, avoid loose clothing if possible, and use extreme caution.*



**WARNING:** *When doing checks and tests on the equipment hydraulics, follow the procedures as they are written. DO NOT change the procedure.*



**WARNING:** *When putting the hydraulic cylinders on this machine through the necessary cycles to check operation or to remove air from a circuit, make sure all people are out of the way.*



**WARNING:** Use insulated gloves or mittens when working with hot parts.



**WARNING:** Lower all attachments to the ground or use stands to safely support the attachments before you do any maintenance or service.



**WARNING:** Pin sized and smaller streams of hydraulic oil under pressure can penetrate the skin and result in serious infection. If hydraulic oil under pressure does penetrate the skin, seek medical treatment immediately. Maintain all hoses and tubes in good condition. Make sure all connections are tight. Make a replacement of any tube or hose that is damaged or thought to be damaged. **DO NOT** use your hand to check for leaks, use a piece of cardboard or wood.



**WARNING:** When removing hardened pins such as a pivot pin, or a hardened shaft, use a soft head (brass or bronze) hammer or use a driver made from brass or bronze and a steel head hammer.



**WARNING:** When using a hammer to remove and install pivot pins or separate parts using compressed air or using a grinder, wear eye protection that completely encloses the eyes (approved goggles or other approved eye protectors).



**WARNING:** Use suitable floor (service) jacks or chain hoist to raise wheels or tracks off the floor. Always block machine in place with suitable safety stands.



**WARNING:** When servicing or repairing the machine, keep the shop floor and operator's compartment and steps free of oil, water, grease, tools, etc. Use an oil absorbing material and/or shop cloths as required. Use safe practices at all times.



**WARNING:** Some components of this machine are very heavy. Use suitable lifting equipment or additional help as instructed in this Service Manual.



**WARNING:** Engine exhaust fumes can cause death. If it is necessary to start the engine in a closed place, remove the exhaust fumes from the area with an exhaust pipe extension. Open the doors and get outside air into the area.



**WARNING:** When the battery electrolyte is frozen, the battery can explode if (1), you try to charge the battery, or (2), you try to jump start and run the engine. To prevent the battery electrolyte from freezing, try to keep the battery at full charge. If you do not follow these instructions, you or others in the area can be injured.

## STANDARD TORQUE DATA FOR CAP SCREWS AND NUTS

### Tightening of cap screws, nuts

Tighten alternately so that tightening torque can be applied evenly. The numbers in the figure below indicate the order of tightening.

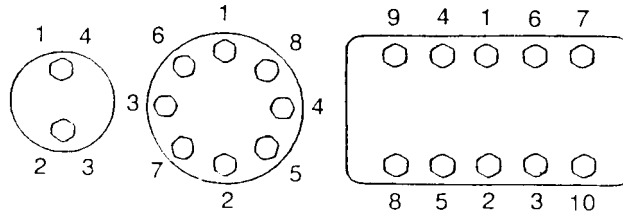

JS00481A

Cap screws which have had Loctite used (white residue remains after removal) should be cleaned with light oil or suitable cleaning solvent and dried. Apply 2-3 drops of Loctite to the thread portion of the cap screw and then tighten.

### Torque table

Tighten cap screws and nuts according to the table below if there are no other special instructions.

Cap Screw Name Size (Size)		M6	M8	M10	M12	M14	M16	M18	M20	
Cap Screw	Spanner	[mm]	10	13	17	19	22	24	27	30
		[in.]	0.39	0.51	0.67	0.75	0.87	0.95	1.06	1.18
	Tightening torque	[Nm]	6.9	19.6	39.2	58.8	98.1	156.9	196.1	294.2
		[lb-ft]	5.1	14.5	28.9	43.4	72.3	115.7	144.6	217
Socket Head Cap Screw	Spanner	[mm]	5	6	8	10	12	14	14	17
		[in.]	0.20	0.24	0.32	0.39	0.47	0.55	0.55	0.67
	Tightening torque	[Nm]	8.8	21.6	42.1	78.5	117.7	176.5	245.2	343.2
		[lb-ft]	6.5	15.9	31.1	57.9	86.9	130.2	181	253.2



# Section 1002

1002

**SPECIFICATIONS  
AND SPECIAL TORQUE SETTINGS**

<http://caseihservicemanual.com>

## TABLE OF CONTENTS



**WARNING:** This symbol is used in this manual to indicate important safety messages. Whenever you see this symbol, carefully read the message which follows. Your safety depends on it.

TYPE, SERIAL NUMBER AND YEAR OF MANUFACTURE OF THE MACHINE .....	3
FLUIDS AND LUBRICANTS .....	4
SPECIFICATIONS.....	8
COMPONENT WEIGHT.....	16
DIMENSIONS AND WEAR LIMIT OF THE TRACK ASSEMBLY .....	18
DIMENSIONS AND WEAR LIMITS OF ATTACHMENT LINKAGES .....	23
SHIMS FOR ADJUSTING ATTACHMENT GAPS.....	28
SPECIAL TORQUE SETTINGS.....	30
MACHINE OVERALL DIMENSIONS.....	33

<https://caseih.servicemanual.com>

## TYPE, SERIAL NUMBER AND YEAR OF MANUFACTURE OF THE MACHINE

For all part orders, request for information or assistance, always specify the type and the serial number of the machine to your Case dealer.

Fill in the following lines with the required information: Type, serial number, year of manufacture of the machine and the serial numbers of the hydraulic and mechanical components.

### Machine

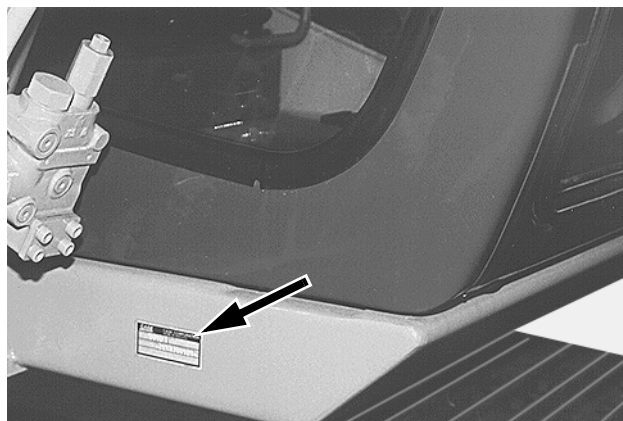

CP98N006

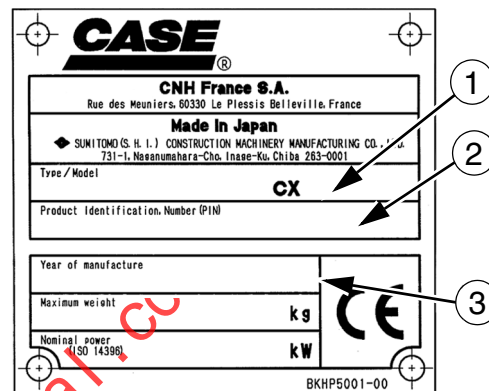

CT04A171A

- (1) Type.....
- (2) Serial number.....
- (3) Year of manufacture.....

### Engine

Make and type .....

Serial number .....

### Serial numbers of the components

Hydraulic pump.....

Swing reduction gear.....

Travel reduction gears .....

Control valve.....

## FLUIDS AND LUBRICANTS

Lubricants must have the correct properties for each application.



**WARNING:** The conditions of use for individual fluids and lubricants must be respected.

### Hydraulic fluid

CASE/AKCELA hydraulic fluid is specially designed for high pressure applications and for the CASE hydraulic system. The type of fluid to be used depends on the ambient temperature.

#### Temperate climates: -20°C to +40°C (-4° to 104° F)

CASE/AKCELA: HYDRAULIC EXCAVATOR FLUID (MS 1230. ISO VG 46. DIN 51524 PART 2 HV)

#### Hot climates: 0°C to +50°C (32° to 122° F)

CASE/AKCELA: AW HYDRAULIC FLUID 68 HV (MS 1216. ISO VG 68. DIN 51524 PART 3 CATEGORY HVLP)

#### Cold climates: -25°C to +20°C (-13° to 68° F)

CASE/AKCELA: AW HYDRAULIC FLUID 32 (MS 1216. ISO VG 32. DIN 51524 PART 2)

#### Biodegradable fluid: -30°C to +40°C (-22° to 104° F)

This yellow-colored fluid is miscible with standard fluid. If used to change standard fluid, it is advised to drain the circuit completely before refilling with this fluid.

CASE/AKCELA: HYDRAULIC EXCAVATOR FLUID BIO (MS 1230. ISO VG 46. DIN 51524 PART 2 HV)

### Transmission component oil

Extreme pressure oil used for enclosed transmission components.

CASE/AKCELA: GEAR 135H EP (SAE 80W-90. API GL 5. MIL-L-2105 D. MS 1316. ZF TE-ML 05A)

### Grease

CASE/AKCELA: MOLY GREASE 251H EP-M (251H EP-M. NLGI 2)

"Extreme Pressure" multipurpose grease with lithium soap and molybdenum disulphide.

CASE/AKCELA: MULTIPURPOSE GREASE 251H EP (251H EP. NLGI 2)

"Extreme Pressure" multipurpose grease with lithium soap and calcium.

CASE/AKCELA: PREMIUM GREASE EP2 (NLGI 2)

"Extreme Pressure" multipurpose grease with lithium soap.

### Hydraulic breakers

CASE/AKCELA: MULTIPURPOSE GREASE 251H EP (NLGI 2).

## Engine Oil

THE CASE/AKCELA No. 1 engine oil is recommended for your engine. This oil ensures proper lubrication of your engine for all operating conditions.

If you are unable to procure the CASE No. 1 Multiperformance or Performance engine oil, use the corresponding oil from the API/CG/CF category.

**NOTE:** Do not put any Performance Additives or any other additives in the engine housing. The oil changing intervals are indicated in the Operator's manual based on tests carried out on CASE lubricants.



CP02N001

### Oil viscosity / Oil range

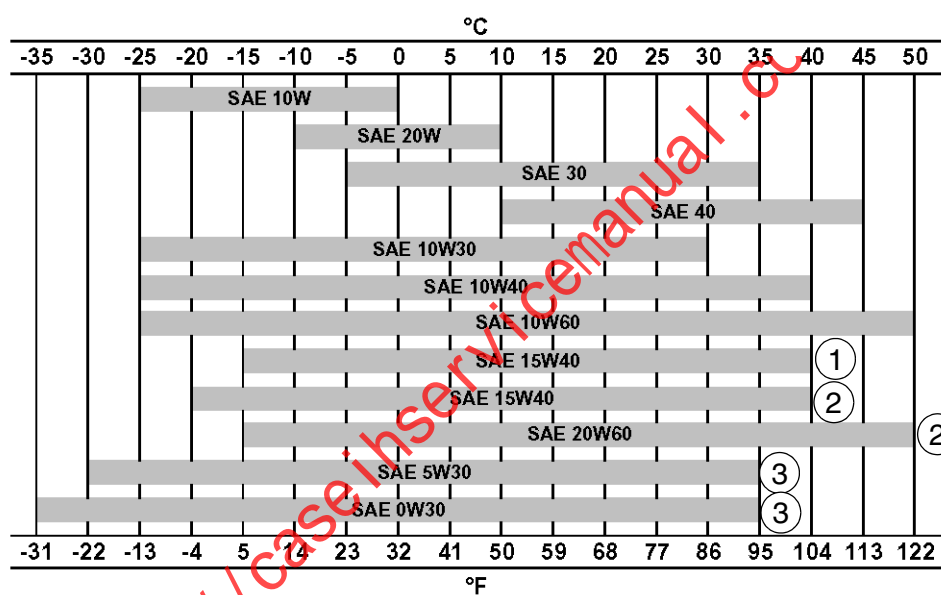

CT02M001

1) With mineral base

(2) With semi-synthetic base

(3) With synthetic base

## Fuel

Use fuel which is to ASTM (American Society for Testing and Materials) D975 standard.

Use grade No. 2-D fuel. The use of other types of fuel can result in a loss of power of the engine and may cause high fuel consumption.

In cold weather (below  $-7^{\circ}\text{C}$ ), it is provisionally approved to use a mixture of fuels No. 1-D and No. 2-D.

If the temperature falls below the fuel cloud point (point at which wax begins to form) the wax crystals will cause power loss or will prevent the engine from starting.

### Required conditions for diesel fuel

The following specific conditions are required for diesel fuel:

- Must be free from minute dust particles.
- Must have adequate viscosity.
- Must have high cetane value.
- Must have high fluidity at low temperature.
- Must have low sulphur content.
- Must have little residual carbon.

### Diesel fuel recommendation

- JIS (Japanese Industrial Standard) : No. 2
- DIN (Deutsche Industrie Normen) : DIN 51601
- SAE (Society of Automotive Engineers) Based on SAE-J-313C: No. 2-D
- BS (British Standard) Based on BS/2869-1970: Class A-1

**IMPORTANT :** *If fuel other than the specified one is used, engine operation will be impaired.*

Using fuels other than those recommended can damage the fuel injection pump, the injector and other parts of the fuel supply system and the engine. **CASE disowns any responsibility concerning this kind of damage, which is not covered by the guarantee.** To avoid any damage to the engine fuel supply system, you are recommended to take the following safety messages into account:

Some fuel suppliers mix used engine oil with diesel fuel. Certain manufacturers of large engines allow them to do this. However, for your engine, do not use diesel fuel contaminated by engine oil. In addition to damaging the engine, this fuel can actually adversely affect the correct purification of exhaust gases. Before using any diesel fuel, ask the supplier if this fuel has been mixed with engine oil.

**IMPORTANT :** *For use of the correct fuel additives, consult your oil or lubrication supplier. Do not inject fuel oil or gasoline, both fuels can damage the engine.*

**IMPORTANT :** *In cold weather, fill the fuel tank at the end of the day's work, in order to prevent the formation of condensation.*

### Fuel storage

Long storage can lead to the accumulation of impurities and condensation in the fuel. Engine trouble can often be traced to the presence of water in the fuel.

The storage tank must be placed outside and the temperature of the fuel should be kept as low as possible. Drain off water and impurities regularly.

## Anti-freeze/Anti-corrosion

Use anti-freeze in all seasons to protect the cooling system from corrosion and all risk of freezing.

CASE/AKCELA: PREMIUM ANTI-FREEZE (MS 1710)

For areas where the temperature goes down to -38°C, mix 50/50 with water.

**IMPORTANT :** *Do not mix products of a different origin or brand. The same product must be used when topping up the system.*

## Environment

Before carrying out any maintenance operation on this machine and before disposing of used fluids or lubricants, always think of the environment. Never throw oil or fluid on the ground and never place it in leaking receptacles.

Contact your local ecological recycling centre to obtain information on the correct method of disposing of these lubricants.

## Plastic and resin parts

When cleaning plastic parts, the console, the instrument panel, the indicators etc... avoid using petrol, kerosene, paint solvents etc... Use only water, soap and a soft cloth.

The use of petrol, kerosene, paint solvents etc... causes discoloration, cracks or deformation of these parts.

<https://caseih.servicemanual.com>

## SPECIFICATIONS

### Main data

Model name .....	CX330 Hydraulic Excavator
.....	CX330NLC Hydraulic Excavator
.....	CX350 Hydraulic Excavator
Operating weight .....	CX330 ..... 34100 kg (75178 lbs)
.....	CX330NLC ..... 34000 kg (74957 lbs)
.....	CX350 ..... 36100kg (79587 lbs)
Engine output .....	202 kW / 2000 rpm

### Performance

Standard weight.....	18.0 kN (4047 lbf)
Swing speed.....	9.6 Tr/min.
Travel speed.....	Low Speed 3.2 km/h (1.9 mph)
.....	High Speed 5.5 km/h (3.4 mph)
Maximum drawbar pull .....	278 kN (62497 lbf)
Grade ability .....	70% (35°)
Ground pressure.....	64 kPa (600 mm (23.6 in) grouser shoe)

### Complete machine dimensions

#### CX330, CX330NLC

	Standard arm 3.25 m (10 ft 8 in)	Super short arm (2.21m) (7 ft 3 in)	Short arm (2.63 m) (8 ft 8 in)	Long arm (4.04 m) (13 ft 3 in)
Length	11050 mm (36 ft 3 in)	11250 mm (36 ft 11 in)	11130 mm (36 ft 6 in)	11090 mm ( 36 ft 3 in)
Width	CX330 = 3200 mm (10 ft 6 in) CX330NLC = 3040 mm (10 ft 0 in)			
Height	3290 mm (10 ft 9 in)	3600 mm (11 ft 9 in)	3530 mm (11 ft 7 in)	3510 mm ( 11 ft 6 in)

#### CX350

	HD Standard arm (3.25 m) (10 ft 8 in)	HD Super short arm (2.21m) (7 ft 3 in)	HD Short arm (2.63 m) (8 ft 8 in)
Length	11050 mm (36 ft 3 in)	11250 mm (36 ft 11 in)	11130 mm (36 ft 6 in)
Width	3200 mm (10 ft 6 in)		
Height	3290 mm (10 ft 9 in)	3570 mm (11ft 8 in)	3530 mm (11 ft 7 in)

### Main body dimensions

Main body length .....	5910 mm (19 ft 5 in)
Main body width.....	3200 mm (10 ft 6 in)
Upper swing body width .....	3040 mm (10 ft 0 in)
Cab width.....	1000 mm (39.36 in)
Main body height .....	3130 mm (10 ft 26 in)
Tail swing radius .....	3450 mm (11 ft 2 in)
Distance of rear swing body .....	3420 mm (11 ft 2.5 in)
Ground clearance for upperstructure.....	1210 mm (4 ft 0.5 in)
Center-to-center of wheels .....	4040 mm (13 ft 3 in)
Overall track length.....	4980 mm (16 ft 2.5 in)
Maximum track width .....	CX330, CX350 ..... 3200 mm (10 ft 6 in)
.....	CX330NLC ..... 2990 mm (9 ft 9 in)
Center-to-center for track.....	CX330, CX350..... 2600 mm (8 ft 6 in)
.....	CX330NLC ..... 2390 mm (7 ft 9.5 in)



Width of track shoe .....	600 mm (23.6 in)
Minimum ground clearance .....	480 mm (19 in) (To bottom of lower frame)

## Engine

Name .....	ISUZU, AH-6HK1XYSS
Type: 4-cycle, water-cooled, overhead camshaft, common rail injection (electric control), with air-cooling type inter-cooler turbo with air-cooling.	
No. of cylinders - bore x stroke .....	6-dia. 115 mm x 125 mm (4.53 x 4.92 in)
Displacement .....	7790 cc (475 cu.in)
Compression ratio .....	17.5
Rated output .....	202± 3.0 kW / 2000 min <sup>-1</sup>
Maximum torque .....	1080Nm (797 lb-ft) / 1500 min <sup>-1</sup>
Engine dimensions (LxWxH) .....	1357 x 995.4 x 1141 mm ( 53.42 x 39.19 x 44.92 in)
Oil pan .....	All direction 35°, inclinable
Starter, reduction type .....	24 V, 5 kW
Alternator, AC type .....	24 V, 50 A
Battery .....	2x 12V/24V,128 Ah/5 Hr

## Cooling system

Fan type .....	diameter 850 mm (33.5 in), suction type-6blades resin & steel
Pulley ratio .....	.80 (reduction)
Direction of rotation .....	Right (viewed from fan side); compliant with
Radiator capacity .....	96.0 kW
Fin type .....	wavy
Fin space .....	2.0 mm (0.08 in)
Oil cooler capacity .....	66.6 kW
Fin type .....	Wavy
Fin space .....	1.75 mm (0.07 in)
Inter-cooler capacity .....	29.9 kW
Fin type .....	triangular straight
Fin space .....	2.0 mm (0.08 in)
Fuel cooler capacity .....	1.7 kW
Fin type .....	wavy
Fin space .....	2.0 mm (0.08 in)

## Capacity of coolant and lubricants

Coolant .....	30 L (7.92 gal)
Fuel.....	580 L (153 gal)
Lubricant for engine .....	38 L (10 gal)
Lubricant for travel reduction gear (per side) .....	9.5 L (2.5 gal)
Lubricant for swing reduction gear (per side) .....	6 L (1.59 gal)
Hydraulic oil .....	350 L (92.5 gal)
Capacity of hydraulic oil tank .....	175 L (46.2 gal)

## Hydraulic oil filter

Suction filter (inside tank) .....	150 mesh
Return filter (inside tank) .....	10 μ m
Nephron filter (inside housing) .....	1 μ m
Pilot line filter (inside housing) .....	10 μ m

## Operating devices

### Operator's seat

Location; left side

Structure; low frequency air suspension with helical springs and double acting hydraulic damper.

### Cab

Smooth and round shape design cab, fabricated by press work Safety glass for all windows.

### Levers and pedals

For travel use; levers and pedals (hydraulic pilot type) (2)

For operating machine use; levers (hydraulic pilot type) (2)

### Instruments and switches

Work mode switchover; 4 modes (heavy digging, standard, finishing and auto)

Travel speed switchover; Low Speed / High Speed panel switch

One-touch idle; Knob switch type

### Monitor device

Machine status display (full-dot liquid crystal)

Travel speed selection status; Low Speed / High Speed

Work mode selection status; H/S/L/A

Auto idle selection status; ON/OFF

### Instruments (full-dot liquid crystal, except for hour meter)

Fuel gauge; bar graph indicator

Engine coolant temperature gauge; bar graph indicator

Hydraulic oil temperature gauge; bar graph indicator

Hour meter; digital type

Machine Status and Warning Alarms (full-dot liquid crystal and warning tone) \*Items have a warning alarm

Over heat*	Battery charge*	Faulty electrical system*
Refill fuel*	Engine oil pressure*	Refill coolant*
Engine preheat	Auto warm-up	Air cleaner*
Idling	Service interval	

### Lighting

Working light	Upper:	24V, 70W (1)
	Boom:	24V, 70W (1)
	Cab:	24V, 70W (1)
Interior light		24V, 10W (1)

### Horn; electric horn (2)

### Other

Wiper with intermittent function (1)

Window washer fluid (1)

Air conditioner (1)

Rear view mirror (right-hand side) (1)

## Hydraulic system

Hydraulic pump drive system, directly coupled to the engine (no transmission)

### Main pump

Manufacturer .....	Kawasaki
Pump type .....	double variable displacement piston pump
Displacement .....	140 cm <sup>3</sup> (8.54 cu in) X 2 /rev
Rated operating pressure .....	34.3 MPa (4975 psi)
Maximum operating pressure .....	37.3 MPa (5410 psi)
Input revolution speed .....	2030 min-1
Maximum flow .....	284 L/min (75 gpm) x 2 at 2030 min-1
Input horsepower .....	171.7 kW
Shaft input horsepower .....	174.7 kW at 2030 min-1
Shaft input torque .....	821.8 N•m (1085 lb-ft) at 2030 min-1

### Pilot pump

Pump type .....	Gear pump
Displacement .....	15 cm <sup>3</sup> (0.91 cu in)/rev
Operating pressure .....	3.9 to 4.1 MPa (565 to 595 psi)
Maximum flow .....	30.5 L/min (8 gpm) at 2030 min-1
Input horsepower .....	3.0 kW

Control characteristics; simultaneous output control of overall, negative control, electric horse power control

### Control Valve

Model; 4-spool section: integrated (1) or 5-spool section: integrated (1)

Operation method; hydraulic pilot method: travel, swing and operating machine

Maximum flow .....	284 L / min (75 gpm)
Set pressure of main relief valve .....	standard; 34.3 MPa (4975 psi), power boost 37.3 MPa (5410 psi)
Set pressure of overload relief valve .....	when boom down; 27.4 MPa (3974 psi) at 20 L / min
.....	other: 39.2 MPa (5685 psi) at 20 L / min
Set pressure of foot relief valve .....	2.89 MPa (420 psi) at 53 L / min

### Functions

- Straight travel circuit
- Boom UP / 2-speed internal confluence for Arm
- Boom/arm load holding circuit
- Boom down regenerative circuit
- Arm IN forced regenerative circuit
- Variable throttle valve in parallel circuit arm
- Swing priority variable throttle valve
- Preliminary 2-speed confluence

### Hydraulic Cylinders

Boom cylinder (2)	
Inner diameter of tube x rod diameter x stroke .....	145x100x1495 mm
Arm (dipper) cylinder	
Inner diameter of tube x rod diameter x stroke .....	170x120x1748 mm
Bucket cylinder	
Inner diameter of tube x rod diameter x stroke .....	150x105x1210 mm

## Rotating Joint

## Operating pressure

High pressure passage (ABCD).....	34.3 MPa (4975 psi)
Drain port (T) .....	1.0 MPa (145 psi)
Pilot port (P) .....	3.9 MPa (566 psi)

## Hydrostatic test pressure

High pressure passage (ABCD).....	51.5 MPa (7470 psi)
Drain port (T) .....	2.0 MPa (290 psi)
Pilot port (P) .....	5.9 MPa (856 psi)

## Flow

High pressure passage (ABCD).....	360 L/min (95 gpm)
Drain port (T) .....	40 L/min (10.6 gpm)
Pilot port (P).....	31 L/min (8.2 gpm)

Number of revolutions ..... 15 min<sup>-1</sup>

Torque, when pressurizing 2 ports ..... 196 Nm (145 lb-ft)

Port A; forward right ..... G1-A Class

Port B; forward left..... G1-A Class

Port C; backward right..... G1-A Class

Port D; backward left..... G1-A Class

Port T; drain port ..... G1/2-A Class

Port P; pilot port ..... G1/4-A Class

## Solenoid Valve

Maximum flow ..... P -> B: 20 L / min (5.28 gpm) Other: 5 L / min (1.32 gpm)

Rated pressure..... 4.41 MPa (640 psi)

Operating voltage ..... DC 20 to 32 V

Current ..... 13.0 W (at 24 V, 20° C)

## Hand control valve

Manufacturer ..... Kawasaki

Operating pressure ..... 3.92 MPa (569 psi)

Secondary pressure, primary short type ..... 0.64 ± 0.1 to 2.45 ± 0.14 MPa

## Operating angle

Ports 1, 3..... 19 ± 1.9°

Ports 2, 4..... 25 ± 2.5°

## Operating torque

Port 1 ..... 1.18 to 2.67 Nm (0.87 to 1.97 lb-ft)

Port 3 ..... 0.94 to 2.38 Nm (0.70 to 1.76 lb-ft)

Ports 2, 4..... 1.37 to 3.19 Nm (1.01 to 2.35 lb-ft)

## Foot control valve

Manufacturer ..... Nishina

Operating pressure ..... 3.92 MPa (569 psi)

Secondary pressure; primary short type ..... 0.64 ± 0.1 to 2.45: 0.14 MPa

Operating angle..... 12.4 ± 0.3°

## Operating torque

Valve ..... 4.16 to 10.6 Nm (3.06 to 7.81 lb-ft)

Damper ..... 4.90 ± 0.98 Nm (3.61 ± 0.72 lb-ft) at 0.0275 m/s

## Digging force (New JIS)

Bucket digging force	
Standard pressure.....	229 kN (51481 lbf)
Power boost pressure.....	248 kN (55753 lbf)
Arm (dipper) digging force	
Standard pressure	
3.25 m arm .....	164 kN (36869 lbf)
2.21m arm .....	227 kN (51031 lbf)
2.63 m arm .....	195 kN (43838 lbf)
4.04 m arm .....	140 kN (31473 lbf)
Power boost pressure	
3.25 m arm .....	178 kN (40016 lbf)
2.21m arm .....	246 kN (55303 lbf)
2.63 m arm .....	211 kN (47435 lbf)
4.04 m arm .....	153 kN (34396 lbf)

## Swing unit

Swing circle; swing bearing type (with internal gears)	
Swing hydraulic motor (1); fixed displacement piston motor with parking brake and reversal prevention valve	
Displacement .....	186.7 cm <sup>3</sup> (11.39 cu in)/rev
Operating pressure.....	29.4 MPa (4264 psi)
Operating flow .....	284 L/min (75 gpm)
Brake torque.....	961.6 Nm (709.24 lb-ft) or over
Brake off pressure .....	2.9 MPa (421 psi) less than
Relief set pressure .....	28.9 to 29.7 MPa (4192 to 4308 psi) at 100 L/min (26 gpm)
Reduction gears, planetary gear 2-stage reduction system	
Reduction ratio .....	27.143
Swing parking brake; mechanical lock (operational lever linkage type)	
Swing lock; mechanical lock (swing lock switch linkage type)	

## Travel lower body

Travel hydraulic motor (2); variable displacement piston motor, automatic 2-speed switch-over with parking brake	
Displacement .....	290.7 / 170.1 cm <sup>3</sup> (17.74/10.38 cu in)/rev
Operating pressure.....	34.3 MPa (4975 psi)
Operating flow .....	284.2 L/min (75 gpm)
Brake torque.....	4738 Nm (3495 lb-ft) or over (excluding reduction gear)
Relief set pressure .....	35.8 MPa (5112 psi) at 5 L/min (1.32 gpm)
2-speed control pressure .....	26.5 ± 1 MPa (3443 psi)
Reduction gears; planetary gear 2-stage reduction system	
Reduction ratio .....	40.467
Travel brake; hydraulic lock	
Parking brake; mechanical lock (travel lever linkage type)	
Track shoe	
Model; assembly-type double grouser shoe	
Number of shoes (per side).....	48
Shoe width	
standard .....	600 mm (23.6 in)
optional CX330 .....	700, 800, 850, 900 mm (26.56, 31.5, 33.5, 35.43 in)
optional CX330NLC, CX350 .....	700, 800 mm (33.5, 35.43 in)
Grouser height .....	36 mm (1.42 in)
Link pitch .....	216 mm (8.5 in)
Roller	
Number of upper rollers (per side) .....	2
Number of lower rollers (per side) .....	8
Track belt tension adjuster; grease cylinder type (with cushion spring)	
mounting length of spring .....	779 mm (30.67 in)

**Work Unit**

Model; backhoe attachment

Capacity / dimensions / working dimensions

Boom length ..... 6450 mm

	Standard arm (3.25 m)	Super short arm (2.21 m)	Short arm (2.63 m)	Super long arm (4.04 m)
Arm length	3250 mm	2210 mm	2630 mm	4040 mm
Bucket radius	1680 mm	1680 mm	1680 mm	1680 mm
Bucket wrist angle	173°	173°	173°	173°
Maximum digging radius	11170 mm	10200 mm	10670 mm	11900 mm
Maximum digging radius at ground line	10980 mm	9990 mm	10470 mm	11720 mm
Maximum digging depth	7340 mm	6300 mm	6730 mm	8140 mm
Maximum vertical straight wall digging depth	6350 mm	5080 mm	5970 mm	7150 mm
Maximum reach height	10370 mm	9850 mm	10320 mm	10670 mm
Maximum dump height	7230 mm	6770 mm	7140 mm	7540 mm
Minimum swing radius at front	4500 mm	4660 mm	4630 mm	4560 mm
Overall height with minimum swing radius at front	8480 mm	8650 mm	8540 mm	8490 mm

<https://caseih.servicemanual.com>

## Reference Values

Numerical values for performance may change without notice due to product improvement.

Items			Reference values		Conditions	
			CX330 CX330NLC	CX350		
1	Engine speed (min <sup>-1</sup> )	Idling	900 ± 20	900 ± 20	Mode: H	
		Maximum without load	1950 ± 10	1950 ± 10		
2	Pressure of each part (MPa)	Main Relief	Standard	34.3 ± 2.0	34.3 ± 2.0	Mode: S
			Boosting	37.3 ± 2.0	37.3 ± 2.0	
		Swing relief	Vertical	31.5 ± 2.0	31.5 ± 2.0	
		Pilot relief	3.9 ± 0.1	3.9 ± 0.1		
3	Natural lowering level of each cylinder (mm)	Boom cylinder	10 or below	10 or below	No load for 10 minutes	
		Arm cylinder	15 or below	15 or below		
		Bucket cylinder (when open)	20 or below	20 or below		
		Overall	250 or below	250 or below	No load for 10 minutes	
4	Operational speed of each cylinder (sec)	Boom	Up	4.5 ± 0.6	4.8 ± 0.6	Mode: S
			Down	3.3 ± 0.6	3.1 ± 0.6	
		Arm	Open	3.8 ± 0.6	3.9 ± 0.6	
			Close	4.9 ± 0.8	4.8 ± 0.8	
		Bucket	Open	3.1 ± 0.6	3.1 ± 0.6	
			Close	5.3 ± 0.3	5.4 ± 0.3	
5	Swing speed (sec/1 revolution)		6.8 ± 0.6	6.8 ± 0.6	Mode: S	
6	Swing angle 180°, neutral brake flow angle (degrees)		40° or below	40° or below	Mode: S	
7	Travel speed (sec/6 m)	High	4.3 ± 0.6	4.3 ± 0.6	Mode: S	
8	Number of drive sprocket revolutions (sec/10 revolutions)	High	16.5 ± 1.5	16.5 ± 1.5	Mode: S	
		Low	27.6 ± 1.8	27.6 ± 1.8		
9	Amount of turntable bearing shift (mm)	Horizontal	6.5 or below	6.5 or below	Mode: S	
		Vertical	2.0 or below	2.0 or below		
10	Amount of shoe tension ranging from the side frame bottom to shoe surface (mm)		340 to 460	340 to 460		

## COMPONENT WEIGHT

### Major component weight

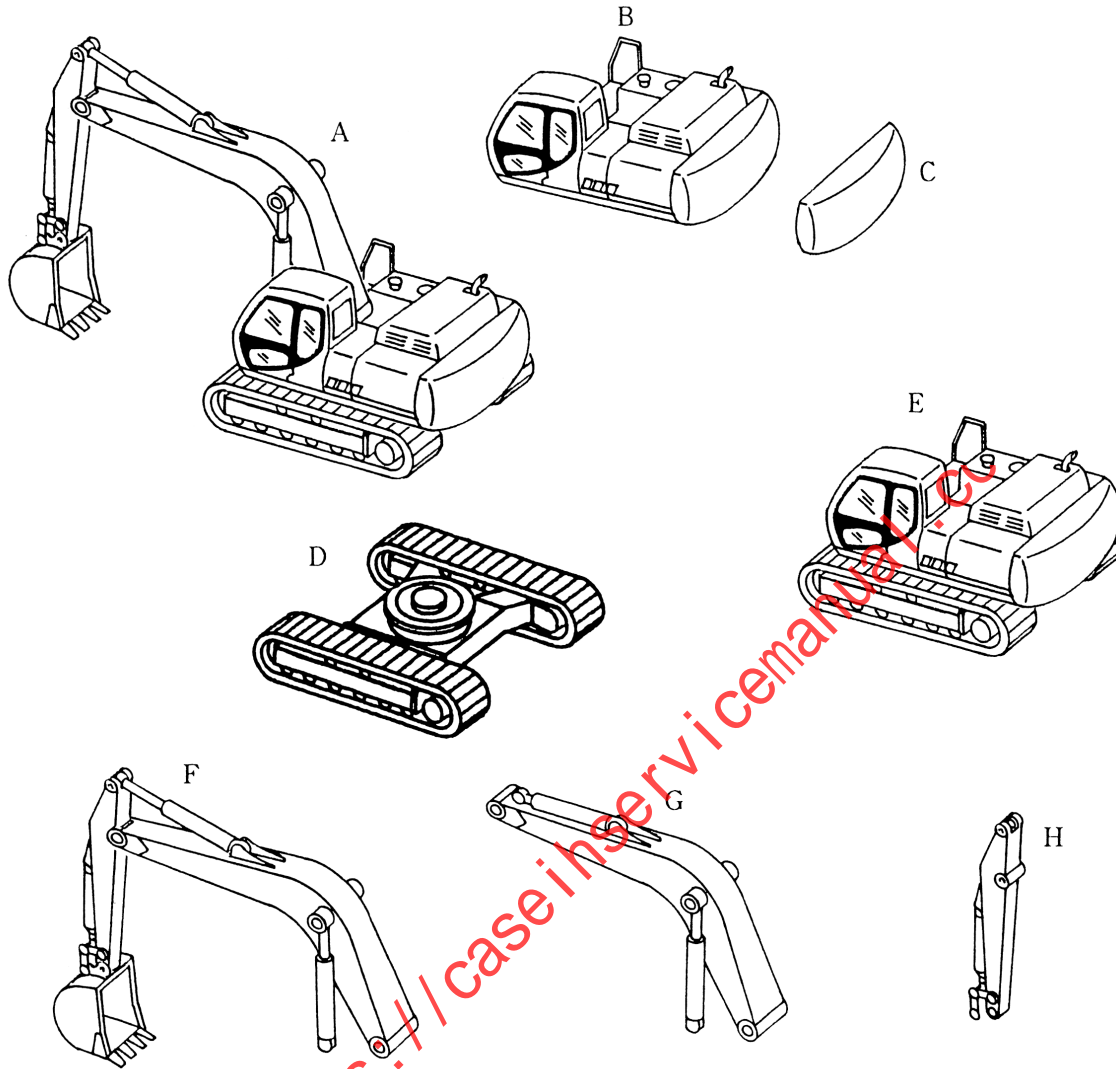

330-3-01-00-46A

Item	Component Name	CX330	CX330NLC	CX350
A	Overall machine	34100 kg (75178 lbs)	34000 kg (74957 lbs)	36100 kg (79587 lbs)
B	Upper structure (including counterweight and turntable bearings)	14720 kg (32472 lbs)		15700 kg (34612 lbs)
C	Counterweight	6410 kg (14132 lbs)		7410 kg (16336 lbs)
D	Bottom structure (with grouser shoe)	12240 kg (26985 lbs)	12150 kg (26786 lbs)	12490 kg (27536 lbs)
E	Machine without attachment	26960 kg (59437 lbs)	26850 kg (59194 lbs)	28200 kg (62170 lbs)
F	Attachments	7030 kg (15498 lbs)		7840 kg (17284 lbs)
G	Boom (including cylinder)	3960 kg (8730 lbs)		4250 kg (9370 lbs)
H	Arm (including cylinder and linkage)	1890 kg (4167 lbs)		2090 kg (4608 lbs)

Weight information is approximate