

<https://caseihservicemanual.com>

**CX350C**  
**CX370C**  
**Hydraulic Excavator**

# Service Manual

**Part Number**  
**48024967**  
1<sup>st</sup> Edition  
English 08/2016





## SERVICE MANUAL

**CX350C CRAWLER EXCAVATOR - BRAZIL MARKET - TIER3  
CX370C Mass excavator model with tier 3 emission level**

<https://caseihservicemanual.com>

# Contents

---

## INTRODUCTION

Engine.....	10
[10.106] Valve drive and gears .....	10.1
[10.101] Cylinder heads .....	10.2
[10.105] Connecting rods and pistons.....	10.3
[10.103] Crankshaft and flywheel.....	10.4
[10.218] Fuel injection system.....	10.5
[10.501] Exhaust Gas Recirculation (EGR) exhaust treatment.....	10.6
[10.400] Engine cooling system .....	10.7
[10.414] Fan and drive .....	10.8
[10.310] Aftercooler.....	10.9
[10.001] Engine and crankcase .....	10.10
[10.102] Pan and covers .....	10.11
[10.206] Fuel filters .....	10.12
[10.216] Fuel tanks .....	10.13
[10.250] Turbocharger and lines.....	10.14
[10.254] Intake and exhaust manifolds and muffler .....	10.15
[10.304] Engine lubrication system.....	10.16
Hydraulic systems.....	35
[35.000] Hydraulic systems.....	35.1
[35.300] Reservoir, cooler, and filters.....	35.2
[35.106] Variable displacement pump .....	35.3
[35.102] Pump control valves.....	35.4
[35.304] Combination pump units .....	35.5
[35.359] Main control valve.....	35.6
[35.352] Hydraulic swing system .....	35.7
[35.353] Hydraulic travel system .....	35.8

[35.354] Hydraulic central joint .....	35.9
[35.355] Hydraulic hand control .....	35.10
[35.356] Hydraulic foot control.....	35.11
[35.357] Pilot system .....	35.12
[35.360] Hammer and rotating bucket hydraulic system .....	35.13
[35.736] Boom hydraulic system .....	35.14
[35.737] Dipper hydraulic system.....	35.15
[35.738] Excavator and backhoe bucket hydraulic system.....	35.16
<b>Frames and ballasting .....</b>	<b>39</b>
[39.140] Ballasts and supports .....	39.1
<b>Tracks and track suspension.....</b>	<b>48</b>
[48.130] Track frame and driving wheels.....	48.1
[48.100] Tracks .....	48.2
[48.134] Track tension units .....	48.3
[48.138] Track rollers .....	48.4
<b>Cab climate control .....</b>	<b>50</b>
[50.100] Heating.....	50.1
[50.200] Air conditioning.....	50.2
<b>Electrical systems.....</b>	<b>55</b>
[55.301] Alternator.....	55.1
[55.302] Battery.....	55.2
[55.010] Fuel injection system.....	55.3
[55.014] Engine intake and exhaust system.....	55.4
[55.989] Exhaust Gas Recirculation (EGR) electrical system .....	55.5
[55.012] Engine cooling system .....	55.6
[55.013] Engine oil system .....	55.7
[55.051] Cab Heating, Ventilation, and Air-Conditioning (HVAC) controls.....	55.8
[55.050] Heating, Ventilation, and Air-Conditioning (HVAC) control system.....	55.9

[55.518] Wiper and washer system.....	55.10
[55.404] External lighting .....	55.11
[55.000] Electrical system .....	55.12
[55.015] Engine control system.....	55.13
[55.036] Hydraulic system control .....	55.14
[55.100] Harnesses and connectors.....	55.15
[55.201] Engine starting system .....	55.16
[55.202] Cold start aid .....	55.17
[55.408] Warning indicators, alarms, and instruments .....	55.18
[55.416] Swing control system .....	55.19
[55.417] Travel control system .....	55.20
[55.512] Cab controls.....	55.21
[55.514] Cab lighting .....	55.22
[55.525] Cab engine controls.....	55.23
[55.530] Camera.....	55.24
[55.640] Electronic modules.....	55.25
[55.992] Anti-theft system .....	55.26
[55.DTC] FAULT CODES.....	55.27
<b>Booms, dippers, and buckets .....</b>	<b>84</b>
[84.910] Boom.....	84.1
[84.912] Dipper arm .....	84.2
[84.100] Bucket.....	84.3
<b>Platform, cab, bodywork, and decals.....</b>	<b>90</b>
[90.120] Mechanically-adjusted operator seat.....	90.1
[90.150] Cab.....	90.2
[90.156] Cab windshield and windows .....	90.3
[90.100] Engine hood and panels .....	90.4



## INTRODUCTION

<https://caseihservicemanual.com>

# Contents

---

## INTRODUCTION

Foreword - Important notice regarding equipment servicing .....	3
Safety rules .....	4
Safety rules - General information .....	5
Safety rules - Personal safety .....	6
Safety rules - Cab protective structure .....	8
Torque - Bolt and nut (*) .....	9
Torque - Special torque setting .....	10
Basic instructions - Shop and assembly .....	14
General specification .....	16
General specification .....	20
General specification - Main equipment .....	24
Weight .....	31
Weight .....	33
Dimension .....	35
Dimension .....	37
Conversion factors .....	39
Consumables .....	51
Capacities .....	53
Abbreviation .....	54
Product identification .....	57
Product identification - Machine orientation .....	59

<https://caseih.servicemanual.com>

(\*) See content for specific models

---

## Foreword - Important notice regarding equipment servicing

All repair and maintenance work listed in this manual must be carried out only by qualified dealership personnel, strictly complying with the instructions given, and using, whenever possible, the special tools.

Anyone who performs repair and maintenance operations without complying with the procedures provided herein shall be responsible for any subsequent damages.

The manufacturer and all the organizations of its distribution chain, including - without limitation - national, regional, or local dealers, reject any responsibility for damages caused by parts and/or components not approved by the manufacturer, including those used for the servicing or repair of the product manufactured or marketed by the manufacturer. In any case, no warranty is given or attributed on the product manufactured or marketed by the manufacturer in case of damages caused by parts and/or components not approved by the manufacturer.

The manufacturer reserves the right to make improvements in design and changes in specifications at any time without notice and without incurring any obligation to install them on units previously sold. Specifications, descriptions, and illustrative material herein are as accurate as known at time of publication but are subject to change without notice.

In case of questions, refer to your CASE CONSTRUCTION Sales and Service Networks.

<https://caseihservicemanual.com>



---

## Safety rules

### Personal safety





This is the safety alert symbol. It is used to alert you to potential personal injury hazards. Obey all safety messages that follow this symbol to avoid possible death or injury.

Throughout this manual you will find the signal words DANGER, WARNING, and CAUTION followed by special instructions. These precautions are intended for the personal safety of you and those working with you.

Read and understand all the safety messages in this manual before you operate or service the machine.

 DANGER indicates a hazardous situation that, if not avoided, will result in death or serious injury.

 WARNING indicates a hazardous situation that, if not avoided, could result in death or serious injury.

 CAUTION indicates a hazardous situation that, if not avoided, could result in minor or moderate injury.

**FAILURE TO FOLLOW DANGER, WARNING, AND CAUTION MESSAGES COULD RESULT IN DEATH OR SERIOUS INJURY.**

### Machine safety

**NOTICE:** Notice indicates a situation that, if not avoided, could result in machine or property damage.

Throughout this manual you will find the signal word Notice followed by special instructions to prevent machine or property damage. The word Notice is used to address practices not related to personal safety.

### Information

**NOTE:** Note indicates additional information that clarifies steps, procedures, or other information in this manual.

Throughout this manual you will find the word Note followed by additional information about a step, procedure, or other information in the manual. The word Note is not intended to address personal safety or property damage.

## **Safety rules - General information**

### **Cleaning**

Clean the metal parts with cleaning solution that meets the standard and steam cleaning. (except for bearings)

After cleaning, dry well, and inject oil in all parts.

Also inject oil into the bearings after drying.

### **Inspection**

When disassembling parts, check all the parts.

If there are any worn or damaged parts, replace them.

Inspect carefully to prevent initial breakdowns.

### **Bearing**

Replace any loose bearings.

Air dry bearings before installing them.

### **Needle bearing**

When inserting needle bearings, be very careful not to damage them.

Apply grease to the section where the needle bearing will be inserted.

### **Gear**

Check that there is no wear and no damage.

### **Oil seal, O-ring, gasket**

Always install new oil seals, O-rings, and gaskets.

Apply grease to sections where oil seals and O-rings will be inserted.

### **Shaft**

Check that there is no wear and no damage.

Check the bearings and check for damaged oil seals on the shaft.

### **Service parts**

Install CASE CONSTRUCTION genuine service parts.

When placing an order, check the parts catalog. It contains the CASE CONSTRUCTION genuine part numbers.

Any breakdowns arising from the installation of non-genuine parts are not covered by the warranty.

### **Lubricants (fuel, hydraulic oil)**

Use the oil from the specified company or specified in the operator's manual or service Manual.

Any breakdowns arising from any fuel or hydraulic oil other than those specified are not covered by the warranty.

## Safety rules - Personal safety

**⚠ WARNING:**

This symbol indicates a precaution.  
It gives information concerning the safety of the operator and those in the surroundings.  
Read and understand these precautions thoroughly before performing the work.

Always comply with warnings and precautions so as to avoid any accidents.

This section covers information related to overall safety.

Check whether all warning labels are in place.

Additional labels can be ordered from Service Parts.

**⚠ WARNING:**

Read the operator's manual to gain a thorough understanding of machine control operations.

**⚠ WARNING:**

Perform any machine operations from the seating position.  
Any other method may cause severe injuries.

**⚠ WARNING:**

Only the one operator is to ride on the machine. No one else is to ride on it.

**⚠ WARNING:**

Check the safety messages in the operator's manual before starting the engine.  
Check all the warning labels on the machine.  
Check that no one is within the machine's operating range.  
Check the operating methods in a safe location before starting the actual work.  
Understand the machine operations well, then operate in compliance with all service-related laws and regulations.  
The operator's manual can be purchased at your CASE CONSTRUCTION dealer.

**⚠ WARNING:**

Working with sloppy clothes or clothes with which safety cannot be ensured leads to damage to the machine and injury to the operator.  
Always wear clothes that ensures safety.  
In order to work more safely, it is recommended to wear additional safety equipment.  
Helmet, safety shoes, ear protection, goggles, work clothes, and gloves

**⚠ WARNING:**

Pay careful attention when working with the engine running.

**⚠ WARNING:**

Check hydraulic equipment.  
Work according to the procedure.  
Do not change the procedure.

## INTRODUCTION



**WARNING:**

Check that there is no one in the surroundings before draining the pressure from hydraulic circuits during machine hydraulic cylinder inspection.



**WARNING:**

Use gloves when handling high-temperature parts.



**WARNING:**

Bring the lower parts or attachments in contact with the ground before inspecting or repairing them.



**WARNING:**

Check that hoses and tubes are securely connected.  
If there is any damage to a hose or tube, replace it.  
Do not check for oil leaks by hand. Use cardboard or wood.



**WARNING:**

When removing an attachment pin or other hardened pin, use a hammer that has a soft head.



**WARNING:**

Wear eye protection when using a hammer to install a pin or when working with a grinder.  
At this time, use goggles or eye protectors that meet standards.



**WARNING:**

Park the machine in a safe location when repairing or inspecting it.



**WARNING:**

Use work site protection when repairing the machine.  
Check the oil, coolant, grease, and tools.  
Recover materials and parts as necessary.  
Pay enough attention to safety.



**WARNING:**

Some of the machine's parts are extremely heavy.  
Use an appropriate lifting equipment for such parts.  
For weights and procedures, see the Service Manual.



**WARNING:**

Exhaust gases are toxic.  
Always provide good ventilation when working indoors or in any other enclosed space.



**WARNING:**

If the electrolytic battery solution freezes, it may explode.

## Safety rules - Cab protective structure

### Cab protective structure

Modifying the cab main components is prohibited in order to protect the operator.

### Prohibited items

- Modifications that reduce the strength of a platform that has a cab with a protective structure mounted on it. (Actions or modifications that reduce the functionality of the anchoring part at the left-rear of the cab)
- Modifications that effect the strength of the cab with a protective structure.

Modifications prohibited (red part)	All modifications (grinding, welding, drilling holes, removing, etc.) are prohibited.
Modifications permitted under conditions (gray part)	Removal of parts is prohibited. Bar welding and making holes (up to diameter <b>20 mm (0.787 in)</b> ) by drilling are possible.

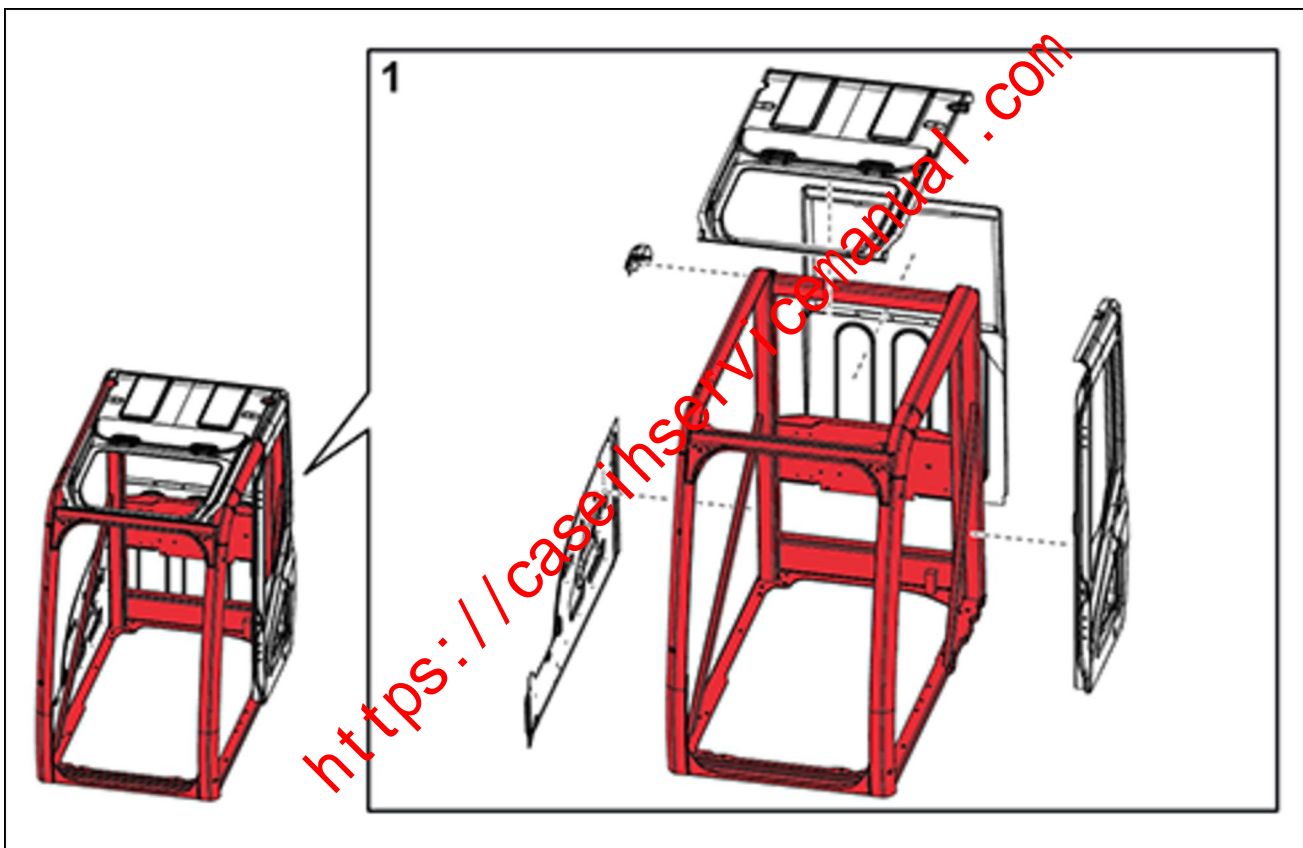

SMPH15CEX6544FA 1

## Torque - Bolt and nut

CX350C CRAWLER EXCAVATOR - BRAZIL MARKET - TIER3	LA
CX370C	LA

- Tighten alternating between left and right and top and bottom so that uniform tightening force is applied.

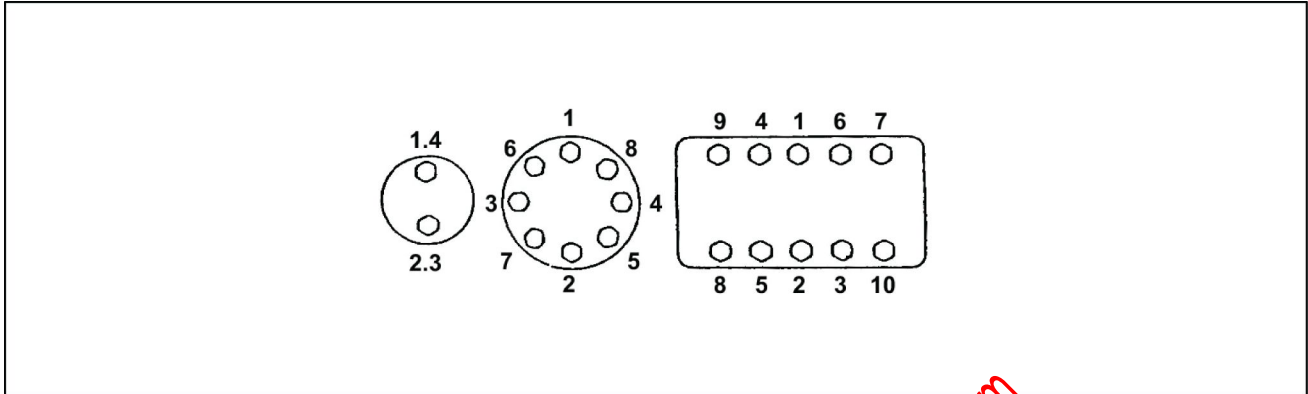

LPIL12CX0005EA 1

- If **LOCTITE®** was used on a removed bolt (there is something white sticking to the bolt when it is removed), clean the old **LOCTITE®** off with cleaning fluid, dry the bolt, then apply 2 - 3 drops of **LOCTITE®** to the thread section of the bolt.

### Torque table

Bolt nominal diameter (size)		M6	M8	M10	M12	M14	M16	M18	M20
Hexagon bolt	Wrench	10 mm	13 mm	17 mm	19 mm	22 mm	24 mm	27 mm	30 mm
	Tightening torque	6.9 N·m (5.089 lb ft)	19.6 N·m (14.456 lb ft)	39.2 N·m (28.912 lb ft)	58.8 N·m (43.369 lb ft)	98.1 N·m (72.355 lb ft)	156.9 N·m (115.72 3 lb ft)	196.1 N·m (144.63 6 lb ft)	294.2 N·m (216.99 1 lb ft)
Hexagon socket head bolt	Wrench	5 mm	6 mm	8 mm	10 mm	12 mm	14 mm	14 mm	17 mm
	Tightening torque	8.8 N·m (6.491 lb ft)	21.6 N·m (15.931 lb ft)	42.1 N·m (31.051 lb ft)	78.5 N·m (57.899 lb ft)	117.7 N·m (86.811 lb ft)	176.5 N·m (130.18 0 lb ft)	245.2 N·m (180.85 0 lb ft)	343.2 N·m (253.13 1 lb ft)

<https://caseihservicemanual.com>

## Torque - Special torque setting

Code	Retightening location		Nominal bolt diameter	Wrench	Tightening torque
1*	Travel motor		M24	36 mm	900 - 1051 N·m (664 - 775 lb ft)
2*	Drive sprocket		M20	30 mm	521 - 608 N·m (384.27 - 448.44 lb ft)
3*	Take-up roller		M16	24 mm	267 - 312 N·m (196.93 - 230.12 lb ft)
4*	Upper roller		M20	30 mm	521 - 608 N·m (384.27 - 448.44 lb ft)
5*	Lower roller		M20	36 mm	902 - 1049 N·m (665.28 - 773.70 lb ft)
6*	Track guard		M20	36 mm	650 - 750 N·m (479.42 - 553.17 lb ft)
7	Shoe		M20	32 mm	1236 - 1510 N·m (911.63 - 1113.72 lb ft)
8	Counterweight		M33	50 mm	1862 - 2058 N·m (1373.34 - 1517.90 lb ft)
9*	Turntable bearing		M24	36 mm	784 - 914 N·m (578.35 - 674.25 lb ft)
10*	Swing unit		M24	36 mm	784 - 914 N·m (578.35 - 674.25 lb ft)
11*	Engine	Mount	M20	30 mm	289 - 337 N·m (213 - 249 lb ft)
12*		Front bracket	M10	17 mm	63.8 - 73.6 N·m (47 - 54 lb ft)
13*		Rear bracket	M12	19 mm	109 - 127 N·m (80 - 94 lb ft)
14*	Radiator		M16	24 mm	147.2 - 176.6 N·m (109 - 130 lb ft)
15*	Hydraulic pump	Flange	M10	17 mm	63.8 - 73.6 N·m (47 - 54 lb ft)
16*		Pump	M20	17 mm hexagon socket head	367 - 436 N·m (270.69 - 365.83 lb ft)
17*	Hydraulic tank		M16	24 mm	233 - 276 N·m (172 - 204 lb ft)
18*	Fuel tank		M16	24 mm	233 - 276 N·m (172 - 204 lb ft)
19*	Control valve		M16	24 mm	267 - 312 N·m (196.93 - 230.12 lb ft)
20*	Center joint	Lock bar	M16	24 mm	267 - 312 N·m (196.93 - 230.12 lb ft)
21*		Joint	M12	19 mm	109 - 127 N·m (80.39 - 93.67 lb ft)
22	Cab		M16	24 mm	149 - 173 N·m (109.90 - 127.60 lb ft)
23	Battery		M10	17 mm	19.6 - 29.4 N·m (14.459 - 21.688 lb ft)

### ⚠ CAUTION:

- For items marked with \*, always apply **Loctite® 262™** or the equivalent and tighten to the specified torque.
- The tightening torque in kgf·m is determined with  $N·m \div 9.8$  (lbf·ft.  $\div 7.2$ ).

Tighten the bolts and nuts for which the values are not specified in the table above as follows.

Nominal bolt diameter (Size)		M6	M8	M10	M12	M14	M16	M18	M20
Hexagon bolt	Wrench	10 mm	13 mm	17 mm	19 mm	22 mm	24 mm	27 mm	30 mm
	Tightening torque	6.9 N·m	19.6 N·m	39.2 N·m	58.8 N·m	98.1 N·m	156.9 N·m	196.1 N·m	294.2 N·m
Hexagon socket head bolt	Wrench	5 mm	6 mm	8 mm	10 mm	12 mm	14 mm	14 mm	17 mm
	Tightening torque	8.8 N·m	21.6 N·m	42.1 N·m	78.5 N·m	117.7 N·m	176.5 N·m	245.2 N·m	343.2 N·m

INTRODUCTION

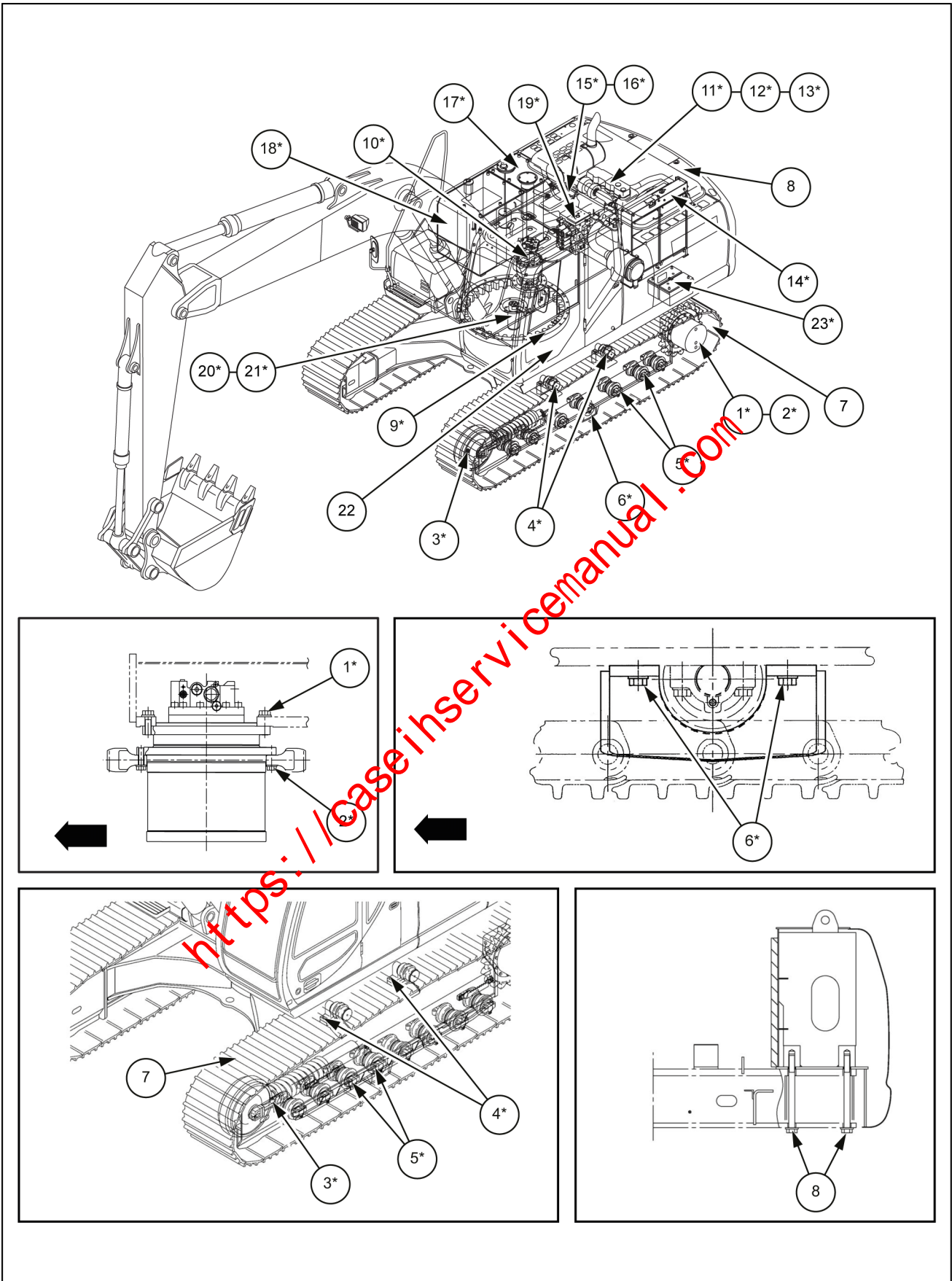

SML14CEX2929HB 1



INTRODUCTION

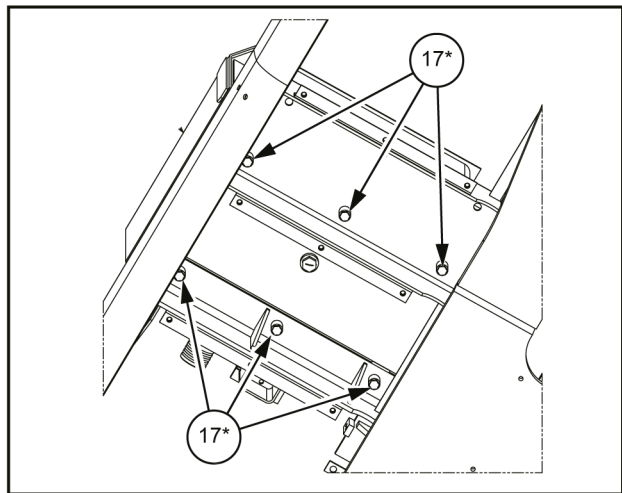
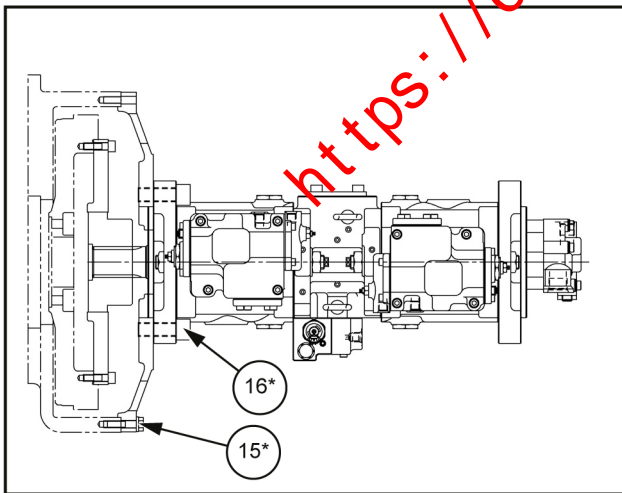
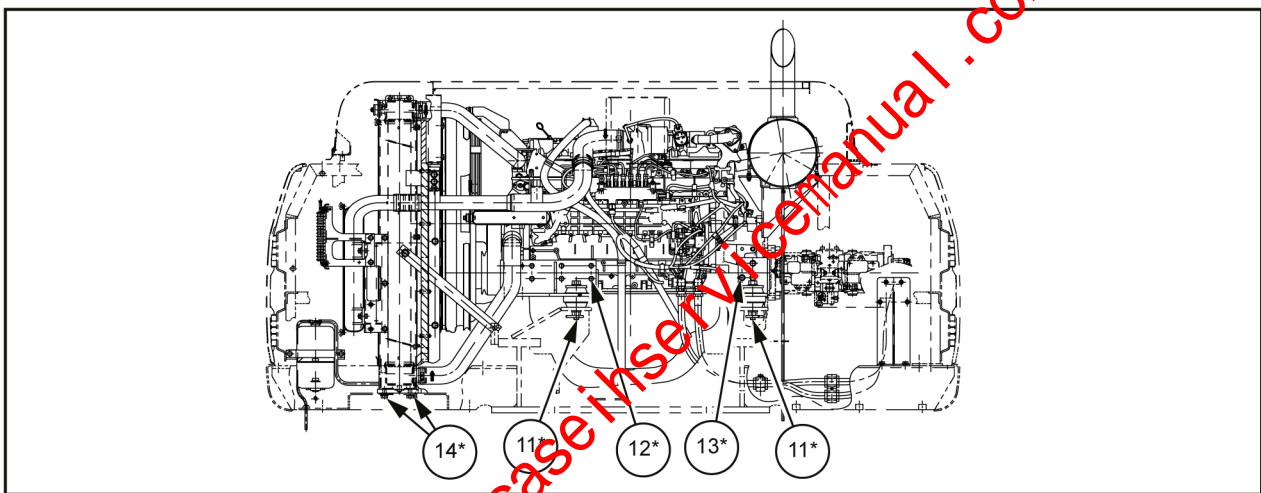
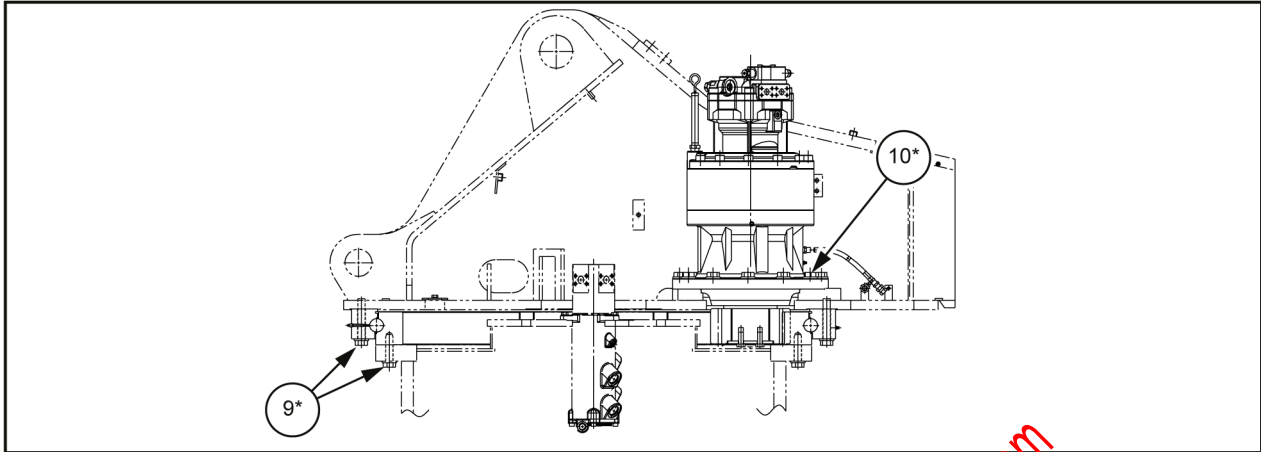

SMIL15CEX3370HB 2

INTRODUCTION

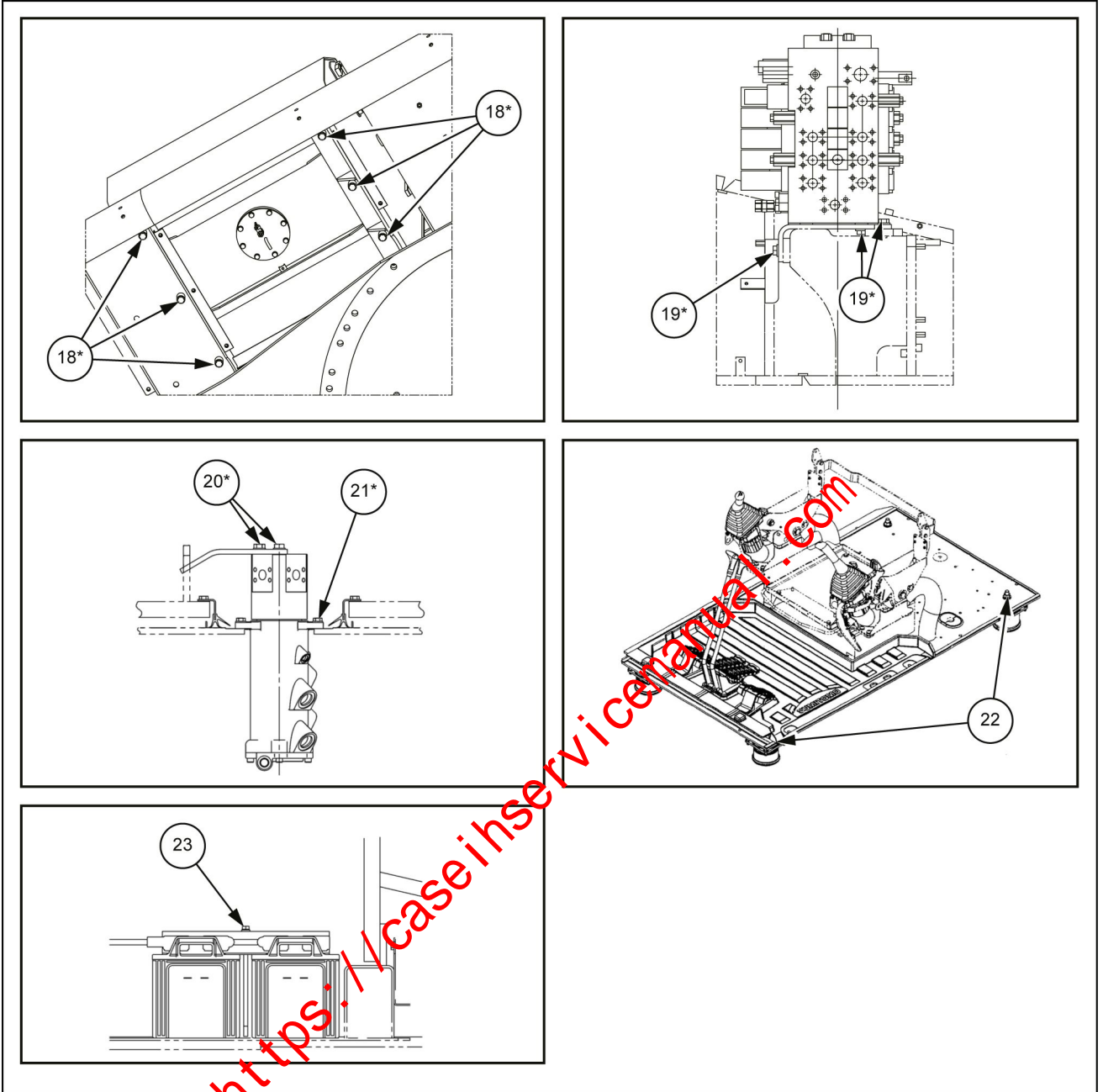

SML15CEX3371GB 3

---

## Basic instructions - Shop and assembly

### Shimming

For each adjustment operation, select adjusting shims and measure the adjusting shims individually using a micrometer, then add up the recorded values. Do not rely on measuring the entire shimming set, which may be incorrect, or the rated value shown on each shim.

### Rotating shaft seals

For correct rotating shaft seal installation, proceed as follows:

1. Before assembly, allow the seal to soak in the oil it will be sealing for at least thirty minutes.
2. Thoroughly clean the shaft and check that the working surface on the shaft is not damaged.
3. Position the sealing lip facing the fluid.

**NOTE:** With hydrodynamic lips, take into consideration the shaft rotation direction and position the grooves so that they will move the fluid towards the inner side of the seal.

4. Coat the sealing lip with a thin layer of lubricant (use oil rather than grease). Fill the gap between the sealing lip and the dust lip on double lip seals with grease.
5. Insert the seal in its seat and press down using a flat punch or seal installation tool. Do not tap the seal with a hammer or mallet.
6. While you insert the seal, check that the seal is perpendicular to the seat. When the seal settles, make sure that the seal makes contact with the thrust element, if required.
7. To prevent damage to the seal lip on the shaft, position a protective guard during installation operations.

### O-ring seals

Lubricate the O-ring seals before you insert them in the seats. This will prevent the O-ring seals from overturning and twisting, which would jeopardize sealing efficiency.

### Sealing compounds

Apply a sealing compound on the mating surfaces when specified by the procedure. Before you apply the sealing compound, prepare the surfaces as directed by the product container.

### Spare parts

Only use CNH Original Parts or CASE CONSTRUCTION Original Parts.

Only genuine spare parts guarantee the same quality, duration, and safety as original parts, as they are the same parts that are assembled during standard production. Only CNH Original Parts or CASE CONSTRUCTION Original Parts can offer this guarantee.

When ordering spare parts, always provide the following information:

- Machine model (commercial name) and Product Identification Number (PIN)
- Part number of the ordered part, which can be found in the parts catalog

---

## Protecting the electronic and/or electrical systems during charging and welding

To avoid damage to the electronic and/or electrical systems, always observe the following practices:

1. Never make or break any of the charging circuit connections when the engine is running, including the battery connections.
2. Never short any of the charging components to ground.
3. Always disconnect the ground cable from the battery before arc welding on the machine or on any machine attachment.
  - Position the welder ground clamp as close to the welding area as possible.
  - If you weld in close proximity to a computer module, then you should remove the module from the machine.
  - Never allow welding cables to lie on, near, or across any electrical wiring or electronic component while you weld.
4. Always disconnect the negative cable from the battery when charging the battery in the machine with a battery charger.

**NOTICE:** *If you must weld on the unit, you must disconnect the battery ground cable from the machine battery. The electronic monitoring system and charging system will be damaged if this is not done.*

5. Remove the battery ground cable. Reconnect the cable when you complete welding.

### **▲ WARNING**

**Battery acid causes burns. Batteries contain sulfuric acid.**

**Avoid contact with skin, eyes or clothing. Antidote (external): Flush with water. Antidote (eyes): flush with water for 15 minutes and seek medical attention immediately. Antidote (internal): Drink large quantities of water or milk. Do not induce vomiting. Seek medical attention immediately. Failure to comply could result in death or serious injury.**

W0111A

## Special tools

The special tools that CASE CONSTRUCTION suggests and illustrate in this manual have been specifically researched and designed for use with CASE CONSTRUCTION machines. The special tools are essential for reliable repair operations. The special tools are accurately built and rigorously tested to offer efficient and long-lasting operation.

By using these tools, repair personnel will benefit from:

- Operating in optimal technical conditions
- Obtaining the best results
- Saving time and effort
- Working in safe conditions

## General specification

### Main data

Operating weight	<b>34930 kg (77007.47 lb)</b>
Engine output	<b>200 kW (271.92 Hp) / 2000 RPM</b>

### Performance

Standard weight	<b>21 kN (4720.988 lb)</b>
Swing speed	<b>10.2 RPM</b>
Travel speed	Low speed <b>3.4 km/h (2.1127 mph)</b>
	High speed <b>5.4 km/h (3.3554 mph)</b>
Maximum pulling force	<b>263 kN (59124.75 lb)</b>
Grade ability	<b>70 % ( 35 ° )</b>
Ground pressure	<b>71 kPa (10 psi) ( 600 mm (23.622 in) grouser shoe)</b>
	<b>54 kPa (8 psi) ( 800 mm (31.496 in) grouser shoe)</b>

### Main unit dimensions

Main unit length	<b>5845 mm (230.118 in)</b>
Main unit width	<b>3200 mm (125.984 in)</b>
Upper swing body width	<b>3035 mm (119.488 in)</b>
Cab width	<b>1000 mm (39.370 in)</b>
Main unit height	<b>3160 mm (124.409 in)</b>
Swing radius (rear end)	<b>3550 mm (139.764 in)</b>
Swing body rear end distance	<b>3520 mm (138.583 in)</b>
Swing body rear section bottom height	<b>1200 mm (47.244 in) [not including lug height of 36 mm (1.417 in) ]</b>
Distance between tumblers	<b>3720 mm (146.457 in)</b>
Overall track length	<b>4650 mm (183.071 in)</b>
Overall track width	<b>3200 mm (125.984 in) (600 G shoe)</b>
Distance between tracks	<b>2600 mm (102.362 in)</b>
Track shoe width	<b>600 mm (23.62 in) option: 800 mm (31.50 in)</b>
Minimum ground clearance	<b>480 mm (18.898 in) (to bottom of lower frame) [not including lug height of 36 mm (1.417 in) ]</b>

### Engine

Name	Isuzu 6HK1X diesel engine
Model	4-cycle, water-cooled, overhead camshaft type Common rail system (electronic control), cooled EGR, with turbocharger (variable displacement type)
No. of cylinders - bore x stroke	<b>6 - Ø115 mm (4.528 in) x 125 mm (4.921 in)</b>
Total stroke volume	<b>7.790 l (7.7900 US gal)</b>
Maximum torque	<b>983 N·m (725.02 lb ft) / 1500 RPM</b>
Starter	<b>24 V 5.0 kW</b> reduction type
Charging generator	<b>24 V 50 A</b> AC type
Battery	<b>12 V 128 A·h / 5 h x 2</b>

### Cooling system

Fan type	<b>Ø850 mm (25.591 in), 6 blades, suction</b>
Radiator	
Fin type	Wavy
Fin pitch	<b>1.75 mm (0.06890 in)</b>
Oil cooler	

INTRODUCTION

Fin type	Wavy
Fin pitch	1.75 mm (0.06890 in)
Intercooler	
Fin type	Wavy
Fin pitch	2.5 mm (0.09843 in)
Fuel cooler	
Fin type	Wavy
Fin pitch	2.0 mm (0.07874 in)

Upper side work system

Type	Backhoe attachment	
Components, dimensions, working dimensions		
Standard bucket capacity	Heaped 1.60 m <sup>3</sup> (56.5 ft <sup>3</sup> ) (Leveled 1.17 m <sup>3</sup> (41.3 ft <sup>3</sup> ))	
Bucket width	1450 mm (57.1 in)	
Bucket width with side cutter	1564 mm (61.6 in)	
Bucket weight with side cutter	1590 kg (3505.3 lb)	
Boom length	6450 mm (253.9 in)	
Arm type	Standard (STD/HD)3.25 m (10.663 ft)	Short (STD/HD)2.63 m (8.629 ft)
Arm length	3250 mm (127.953 in)	2630 mm (103.543 in)
Bucket radius	380 mm (66.142 in)	
Bucket wrist angle	173°	
Maximum digging radius	11170 mm (439.764 in)	10670 mm (420.079 in)
Maximum digging radius at ground line	10980 mm (432.28 in)	10470 mm (412.20 in)
Maximum digging depth	7340 mm (288.976 in)	6730 mm (264.961 in)
Maximum vertical straight wall digging depth	6350 mm (250.000 in)	5970 mm (235.039 in)
Maximum digging height	10370 mm (408.268 in)	10320 mm (406.299 in)
Maximum dump height	7230 mm (284.646 in)	7140 mm (281.102 in)
Minimum swing radius at front	4500 mm (177.165 in)	4630 mm (182.283 in)
Height for minimum swing radius at front	8480 mm (333.858 in)	8540 mm (336.220 in)

Operating device

Operator's seat		
Position	Left side	
Structure	Adjustable forward, back, up and down, reclining mechanism, with seat suspension	
Cab		Sealed steel, type, all reinforced glass, with sun roof
Levers and pedals		
For travel use	Lever and pedal type (hydraulic pilot type) x 2	
For operating machine use	Lever type (hydraulic pilot type) x 2	
Instruments and switches		
Work mode switchover		3 modes ( SP/H/A )

Travel mode switchover	Low-speed/high-speed switch type
One-touch idle	Knob switch type
Engine emergency stop	Switch type
Monitor device	
Machine status display ( TFT color liquid crystal)	
Message display	
Work mode select status	SP/H/A
Instruments	
Fuel gauge	
Engine coolant temperature gauge	
Hydraulic oil temperature gauge	
Hour meter	

## INTRODUCTION

Warning display and warning alarm * has warning alarm		
OVERHEAT (*) ALTERNATOR (*) ELEC PROBLEM (*) LOW FUEL (*) LOW OIL PRESS. (*) LOW COOLANT (*) ENG. PRE HEAT AUTO WARM UP AIR FILTER (*) SECURITY ON CHECK ENGINE (*) ENGINE STOP (*)		
Illumination equipment		
Working light	Right front tool box front surface	24V 70W x1
	Boom side	24V 70W x1
Interior light		24V 70W x1
Horn		Electric horn x2
Other		DC converter, AM/FM radio, wiper with intermittent function, window washer, air conditioner, 2 rear view mirrors (1 on cab side, 1 on front right stay), pre-cleaner (option), polycarbonate sunroof (option), cab light (option), rear view camera/side camera (option), feed pump (option)

### Swing units

Swing circle	Swing bearing type (with inner gear)
Swing hydraulic motor	Fixed displacement piston motor x 1
Reduction gear	Planetary gear 2-stage reduction gear
Swing parking brake	Mechanical lock (operational lever linkage type)

### Undercarriage

Travel hydraulic motor	Variable displacement piston motor x2
Reduction gear	Planetary gear 2-stage reduction gear (made by KYB)
Travel brake	Hydraulic lock
Parking brake	Mechanical lock (travel lever linkage type)
Track shoe	
Type	Assembly-type triple grouser shoe
No. of shoe plates (per side)	45
Shoe width	<b>600 mm (23.622 in)</b> (option <b>800 mm (31.496 in)</b> )
Grouser height	<b>36 mm (1.417 in)</b>
Link pitch	<b>216 mm (8.504 in)</b>
Roller	
No. of upper rollers (per side)	2
No. of lower rollers (per side)	7
Track belt tension adjuster	Grease cylinder type (with cushion spring)

### Hydraulic equipment

#### Hydraulic device

Hydraulic pump drive type	Direct engine link (no transmission)
Hydraulic pump	
Type	Double variable displacement piston pump x 1 Gear pump x 1
Discharge volume	Piston pump 2 x <b>300 l/min (300.000 US gpm)</b> Gear pump <b>30 l/min (30.000 US gpm)</b>
Pump control method	Simultaneous output full-horsepower control
Set pressure of main relief valve	<b>34.3 MPa (4975 psi)</b> [ <b>37.3 MPa (5410 psi)</b> for pressure boost]
Set pressure of overload relief valve	<b>27.4 MPa (3974 psi)</b> (boom down) <b>39.2 MPa (5686 psi)</b> (boom up/arm/bucket)
Add-on pump (option)	
Manufacturer	KYB Corporation
Type	Gear pump x 1

## INTRODUCTION

	Discharge volume	<b>62 l/min (62.000 US gpm)</b>
	Relief set pressure	<b>20.6 MPa (2988.106 psi)</b>

### Control valve and cylinder

Control valve		
	Model	Quadruple spool + quintuple spool x 1
	Operating method	Hydraulic pilot type: Travel, swing, and operating machine
Cylinder		
		No. of cylinders x tube bore - rod diameter - stroke
	Boom cylinder	2 x <b>Ø145 mm (5.709 in) - Ø100 mm (3.937 in) - 1495 mm (58.858 in)</b>
	Arm cylinder	1 x <b>Ø170 mm (6.693 in) - Ø120 mm (4.724 in) - 1748 mm (68.819 in)</b>
	Bucket cylinder	1 x <b>Ø150 mm (5.906 in) - Ø105 mm (4.134 in) - 1210 mm (47.638 in)</b>

### Filters

#### Hydraulic filters

Suction filter (inside tank)	105 µm
Return filter (inside tank)	6 µm
Pilot line filter (inside pump chamber))	8 µm

#### Fuel filters

Main filter	2 µm
Pre-filter	5.5 µm

https://caseih.servicemanual.com



## General specification

### Main data

Operating weight	<b>35830 kg (78991.63 lb)</b>
Engine output	<b>200 kW (271.92 Hp) / 2000 RPM</b>

### Performance

Standard weight	<b>21 kN (4720.988 lb)</b>
Swing speed	<b>10.2 RPM</b>
Travel speed	Low speed <b>3.4 km/h (2.1127 mph)</b>
	High speed <b>5.4 km/h (3.3554 mph)</b>
Maximum pulling force	<b>263 kN (59124.75 lb)</b>
Grade ability	<b>70 % ( 35 ° )</b>
Ground pressure	<b>67 kPa (9.72 psi) ( 600 mm (23.622 in) grouser shoe)</b>
	<b>51 kPa (7 psi) ( 800 mm (31.496 in) grouser shoe)</b>

### Main unit dimensions

Main unit length	<b>6010 mm (236.614 in)</b>
Main unit width	<b>3200 mm (125.984 in)</b>
Upper swing body width	<b>3075 mm (121.063 in)</b>
Cab width	<b>1000 mm (39.370 in)</b>
Main unit height	<b>3160 mm (124.409 in)</b>
Swing radius (rear end)	<b>3550 mm (139.764 in)</b>
Swing body rear end distance	<b>3520 mm (138.583 in)</b>
Swing body rear section bottom height	<b>1200 mm (47.244 in) [not including lug height of 36 mm (1.417 in) ]</b>
Distance between tumblers	<b>4040 mm (159.055 in)</b>
Overall track length	<b>4980 mm (196.063 in)</b>
Overall track width	<b>3200 mm (125.984 in) (600 G shoe)</b>
Distance between tracks	<b>2600 mm (102.362 in)</b>
Track shoe width	<b>600 mm (23.62 in) option: 800 mm (31.50 in)</b>
Minimum ground clearance	<b>480 mm (18.898 in) (to bottom of lower frame) [not including lug height of 36 mm (1.417 in) ]</b>

### Engine

Name	Isuzu 6HK1X diesel engine
Model	4-cycle, water-cooled, overhead camshaft type Common rail system (electronic control), cooled EGR, with turbocharger (variable displacement type)
No. of cylinders - bore x stroke	<b>6 - Ø115 mm (4.528 in) x 125 mm (4.921 in)</b>
Total stroke volume	<b>7.790 l (7.7900 US gal)</b>
Maximum torque	<b>983 N·m (725.02 lb ft) / 1500 RPM</b>
Starter	<b>24 V 5.0 kW</b> reduction type
Charging generator	<b>24 V 50 A</b> AC type
Battery	<b>12 V 128 A·h / 5 h x 2</b>

### Cooling system

Fan type	<b>Ø850 mm (25.591 in), 6 blades, suction</b>
Radiator	
Fin type	Wavy
Fin pitch	<b>1.75 mm (0.06890 in)</b>
Oil cooler	

INTRODUCTION

	Fin type	Wavy
	Fin pitch	1.75 mm (0.06890 in)
Intercooler		
	Fin type	Wavy
	Fin pitch	2.5 mm (0.09843 in)
Fuel cooler		
	Fin type	Wavy
	Fin pitch	2.0 mm (0.07874 in)

Upper side work system

Type	Backhoe attachment	
Components, dimensions, working dimensions		
	Standard bucket capacity	Heaped 1.60 m <sup>3</sup> (56.5 ft <sup>3</sup> ) (Leveled 1.17 m <sup>3</sup> (41.3 ft <sup>3</sup> ))
	Bucket width	1450 mm (57.1 in)
	Bucket width with side cutter	1564 mm (61.6 in)
	Bucket weight with side cutter	1590 kg (3505.3 lb)
	Boom length	6450 mm (253.9 in)
	Arm type	Standard (STD/HD)3.25 m (10.663 ft) Short (STD/HD)2.63 m (8.629 ft)
	Arm length	3250 mm (127.953 in) 2630 mm (103.543 in)
	Bucket radius	3380 mm (66.142 in)
	Bucket wrist angle	173°
	Maximum digging radius	11170 mm (439.764 in) 10670 mm (420.079 in)
	Maximum digging radius at ground line	10980 mm (432.28 in) 10470 mm (412.20 in)
	Maximum digging depth	7340 mm (288.976 in) 6730 mm (264.961 in)
	Maximum vertical straight wall digging depth	6350 mm (250.000 in) 5970 mm (235.039 in)
	Maximum digging height	10370 mm (408.268 in) 10320 mm (406.299 in)
	Maximum dump height	7230 mm (284.646 in) 7140 mm (281.102 in)
	Minimum swing radius at front	4500 mm (177.165 in) 4630 mm (182.283 in)
	Height for minimum swing radius at front	8480 mm (333.858 in) 8540 mm (336.220 in)

Operating device

Operator's seat		
	Position	Left side
	Structure	Adjustable forward, back, up and down, reclining mechanism, with seat suspension
Cab		Sealed steel, type, all reinforced glass, with sun roof
Levers and pedals		
	For travel use	Lever and pedal type (hydraulic pilot type) x 2
	For operating machine use	Lever type (hydraulic pilot type) x 2
Instruments and switches		
Work mode switch over		3 modes ( SP/H/A )

	Travel mode switch over	Low-speed/high-speed switch type
	One-touch idle	Knob switch type
	Engine emergency stop	Switch type
Monitor device		
	Machine status display ( TFT color liquid crystal)	
	Message display	
	Work mode select status	SP/H/A
Instruments		
	Fuel gauge	
	Engine coolant temperature gauge	
	Hydraulic oil temperature gauge	
	Hour meter	

## INTRODUCTION

Warning display and warning alarm * has warning alarm		
OVERHEAT (*) ALTERNATOR (*) ELEC PROBLEM (*) LOW FUEL (*) LOW OIL PRESS. (*) LOW COOLANT (*) ENG. PRE HEAT AUTO WARM UP AIR FILTER (*) SECURITY ON CHECK ENGINE (*) ENGINE STOP (*)		
Illumination equipment		
Working light	Right front tool box front surface	24V 70W x1
	Boom side	24V 70W x1
Interior light		24V 70W x1
Horn		Electric horn x2
Other		DC converter, AM/FM radio, wiper with intermittent function, window washer, air conditioner, 2 rear view mirrors (1 on cab side, 1 on front right stay), pre-cleaner (option), polycarbonate sunroof (option), cab light (option), rear view camera/side camera (option), feed pump (option)

### Swing units

Swing circle	Swing bearing type (with inner gear)
Swing hydraulic motor	Fixed displacement piston motor x 1
Reduction gear	Planetary gear 2-stage reduction gear
Swing parking brake	Mechanical lock (operational lever linkage type)

### Undercarriage

Travel hydraulic motor	Variable displacement piston motor x2
Reduction gear	Planetary gear 2-stage reduction gear (made by KYB)
Travel brake	Hydraulic lock
Parking brake	Mechanical lock (travel lever linkage type)
Track shoe	
Type	Assembly-type triple grouser shoe
No. of shoe plates (per side)	48
Shoe width	<b>600 mm (23.622 in)</b> (option <b>800 mm (31.496 in)</b> )
Grouser height	<b>36 mm (1.417 in)</b>
Link pitch	<b>216 mm (8.504 in)</b>
Roller	
No. of upper rollers (per side)	2
No. of lower rollers (per side)	8
Track belt tension adjuster	Grease cylinder type (with cushion spring)

### Hydraulic equipment

#### Hydraulic device

Hydraulic pump drive type	Direct engine link (no transmission)
Hydraulic pump	
Type	Double variable displacement piston pump x 1 Gear pump x 1
Discharge volume	Piston pump 2 x <b>300 l/min (300.000 US gpm)</b> Gear pump <b>30 l/min (30.000 US gpm)</b>
Pump control method	Simultaneous output full-horsepower control
Set pressure of main relief valve	<b>34.3 MPa (4975 psi)</b> [ <b>37.3 MPa (5410 psi)</b> for pressure boost]
Set pressure of overload relief valve	<b>27.4 MPa (3974 psi)</b> (boom down) <b>39.2 MPa (5686 psi)</b> (boom up/arm/bucket)
Add-on pump (option)	
Manufacturer	KYB Corporation
Type	Gear pump x 1

INTRODUCTION

Discharge volume	62 l/min (62.000 US gpm)
Relief set pressure	20.6 MPa (2988.106 psi)

**Control valve and cylinder**

Control valve	
Model	Quadruple spool + quintuple spool x 1
Operating method	Hydraulic pilot type: Travel, swing, and operating machine
Cylinder	
	No. of cylinders x tube bore - rod diameter - stroke
Boom cylinder	2 x Ø145 mm (5.709 in) - Ø100 mm (3.937 in) - 1495 mm (58.858 in)
Arm cylinder	1 x Ø170 mm (6.693 in) - Ø120 mm (4.724 in) - 1748 mm (68.819 in)
Bucket cylinder	1 x Ø150 mm (5.906 in) - Ø105 mm (4.134 in) - 1210 mm (47.638 in)

**Filters**

**Hydraulic filters**

Suction filter (inside tank)	105 µm
Return filter (inside tank)	6 µm
Pilot line filter (inside pump chamber))	8 µm

**Fuel filters**

Main filter	2 µm
Pre-filter	5.5 µm

<https://caseih.servicemanual.com>

## General specification - Main equipment

### Lower component

#### Travel unit

Manufacturer	KYB Corporation
Motor type	Variable displacement piston motor
	Automatic 2-speed switchover with parking brake
Intake amount	<b>181.3 cm<sup>3</sup>/rev (11.06 in<sup>3</sup>/rev)</b>
Operating pressure	<b>34.3 MPa (4975 psi)</b>
Operating flow	<b>300 l/min (300.0000 US gpm)</b>
Brake torque	<b>41.285 N·m (30 lb ft) min.</b> (including reduction gear)
Relief valve set pressure	<b>35.3 MPa (5120 psi)</b>
Automatic 2-speed switch over pressure	<b>25.8 MPa (3742 psi)</b>
Reduction gear	
Reduction gear type	Planetary gear 2-stage reduction gear
Reduction ratio	65.783
Dry weight	<b>394 kg (868.621 lb)</b>

#### Take-up roller

Weight	<b>174 kg (383.6043 lb)</b>
--------	-----------------------------

#### Upper roller

Weight	<b>42 kg (92.5942 lb)</b>
--------	---------------------------

#### Lower roller

Weight	<b>61 kg (134.4820 lb)</b>
--------	----------------------------

#### Recoil spring

Item	Weight	Quantity
Yoke	<b>39.3 kg (86.6417 lb)</b>	1
Sems B <b>M16 x 50</b>	<b>0.1 kg (0.2205 lb)</b>	4
Threaded rod	<b>50.7 kg (111.7744 lb)</b>	1
Groove height N <b>M64</b>	<b>1.9 kg (4.1888 lb)</b>	1
SP pin 10 x 100	<b>0.1 kg (0.2205 lb)</b>	1
Recoil spring	<b>124.6 kg (274.6960 lb)</b>	1
Grease cylinder assembly	<b>41.1 kg (90.6100 lb)</b>	1
Sems B <b>M16 x 65</b>	<b>0.2 kg (0.4409 lb)</b>	2
Assembly (total)	<b>258.5 kg (569.9 lb)</b>	
Mounting length of spring	<b>781 mm (22.68 in)</b>	

#### Shoe

	Weight or Quantity
600 grouser	<b>2098 kg (4625.298 lb)</b>
Link	1 set
Shoe	45
Bolt	180
Nut	180
800 grouser	<b>2455 kg (5412.349 lb)</b>
Link	1 set
Shoe	45
Bolt	180
Nut	180

**Upper component****Swing unit**

Swing motor assembly		
Swing motor		
Manufacturer	Kawasaki Precision Machinery Ltd.	
Motor type	Fixed displacement piston motor	
	With parking brake	
Intake amount	<b>180.1 cm<sup>3</sup>/rev (10.99 in<sup>3</sup>/rev)</b>	
Operating pressure	<b>30.4 MPa (4410 psi)</b>	
Operating flow	<b>300 l/min (300.0000 US gpm)</b>	
Mechanical brake torque	<b>1010.8 N·m (745.528 lb ft) min.</b>	
Brake off pressure	<b>3.1 MPa (450 psi) or less</b>	
Relief valve set pressure	<b>30.4 MPa (4410 psi)</b>	
Swing reduction gear		
Reduction gear type	Planetary reduction gear	
Reduction ratio	27.143	
Dry weight	<b>437 kg (963.420 lb)</b>	
Turntable bearing		
No. of teeth	92	
Weight	<b>540 kg (1190.496 lb)</b>	
Counterweight		
Weight	<b>7400 kg (16314.207 lb)</b>	

**Engine-related****Engine**

Engine model name	Isuzu 6HK1 diesel engine
Engine type	4-cycle, water-cooled, overhead camshaft type straight cylinder, direct fuel injection type (electronic control)
Number of cylinders-bore-stroke	4 - $\varnothing$ 115 mm (4.53 in) - 125 mm (4.92 in)
Total displacement	<b>7.79 l (7.7900 US gal)</b>
Compression ratio	17.5
Rated output	<b>200 kW (271.92 Hp) / 2000 RPM</b>
Maximum torque	<b>983 N·m (725.02 lb ft) / about 1500 RPM</b>
Fuel consumption ratio	<b>*** g/kWh</b>
Engine dry weight	About <b>640 kg (1410.958 lb)</b>
Engine dimension	<b>L 1357 mm (53.4252 in) - W 995.4 mm (39.189 in) - H 1162.5 mm (45.7677 in)</b>
Cooling fan	$\varnothing$ <b>850 mm (33.465 in)</b> - suction type - 6 vanes, plastic and steel
	With bell mouth-type fan guide
Pulley ratio	0.9 (reduction)
Charging generator	<b>24 V 50 A AC type</b>
Starter motor	<b>24 V 5 kW (6.8 Hp) reduction type</b>
Coolant capacity	<b>14.5 l (14.500 US gal)</b>
Oil pan capacity	Max: <b>46 l (46.000 US gal)</b> Min: <b>36 l (36.000 US gal)</b> KSH 10440
Direction of rotation	Right (viewed from fan side)
	Compliant with JISD 0006-2010

**Muffler**

Manufacturer	Sankei Giken Kogyo Co., Ltd.
Type	$\varnothing$ <b>283.2 mm (11.1496 in) x 780 l (780.000 US gal)</b>
Maximum displacement	<b>45300 L/min (11967.0 US gpm)</b>
Weight	<b>19 kg (41.8878 lb)</b>