

caseih.servicemanual.com

CX800B
Crawler Excavator

SERVICE MANUAL

Part number 48020292

English

June 2016

© 2016 CNH Industrial Italia S.p.A. All Rights Reserved.

CASE
CONSTRUCTION



SERVICE MANUAL

CX800B CX800B RTC MASS EXC

caseih.servicemanual.com

Contents

INTRODUCTION

Machine completion and equipment.....	05
[05.200] Product shipment	05.1
Engine.....	10
[10.501] Exhaust Gas Recirculation (EGR) exhaust treatment.....	10.1
[10.001] Engine and crankcase	10.2
[10.102] Pan and covers	10.3
[10.106] Valve drive and gears	10.4
[10.101] Cylinder heads	10.5
[10.105] Connecting rods and pistons.....	10.6
[10.103] Crankshaft and flywheel.....	10.7
[10.216] Fuel tanks	10.8
[10.206] Fuel filters	10.9
[10.218] Fuel injection system.....	10.10
[10.202] Air cleaners and lines	10.11
[10.250] Turbocharger and lines.....	10.12
[10.254] Intake and exhaust manifolds and muffler	10.13
[10.400] Engine cooling system	10.14
[10.414] Fan and drive	10.15
[10.310] Aftercooler.....	10.16
[10.304] Engine lubrication system.....	10.17
[10.408] Oil cooler and lines.....	10.18
Hydraulic systems.....	35
[35.000] Hydraulic systems.....	35.1
[35.300] Reservoir, cooler, and filters.....	35.2
[35.104] Fixed displacement pump.....	35.3

[35.106] Variable displacement pump	35.4
[35.102] Pump control valves.....	35.5
[35.359] Main control valve	35.6
[35.357] Pilot system	35.7
[35.752] Hydraulic fan drive cooling system.....	35.8
[35.355] Hydraulic hand control	35.9
[35.356] Hydraulic foot control.....	35.10
[35.352] Hydraulic swing system	35.11
[35.353] Hydraulic travel system	35.12
[35.354] Hydraulic central joint	35.13
[35.736] Boom hydraulic system	35.14
[35.737] Dipper hydraulic system.....	35.15
[35.738] Excavator and backhoe bucket hydraulic system.....	35.16
[35.360] Hammer and rotating bucket hydraulic system	35.17
Frames and ballasting	39
[39.140] Ballasts and supports	39.1
Tracks and track suspension.....	48
[48.130] Track frame and driving wheels.....	48.1
[48.100] Tracks	48.2
[48.134] Track tension units	48.3
[48.138] Track rollers	48.4
Cab climate control	50
[50.100] Heating.....	50.1
[50.200] Air conditioning.....	50.2
Electrical systems	55
[55.000] Electrical system	55.1
[55.100] Harnesses and connectors.....	55.2
[55.525] Cab engine controls.....	55.3

[55.015] Engine control system.....	55.4
[55.201] Engine starting system.....	55.5
[55.301] Alternator.....	55.6
[55.302] Battery.....	55.7
[55.202] Cold start aid.....	55.8
[55.011] Fuel tank system.....	55.9
[55.010] Fuel injection system.....	55.10
[55.014] Engine intake and exhaust system.....	55.11
[55.989] Exhaust Gas Recirculation (EGR) electrical system.....	55.12
[55.012] Engine cooling system.....	55.13
[55.013] Engine oil system.....	55.14
[55.640] Electronic modules.....	55.15
[55.512] Cab controls.....	55.16
[55.035] Remote control valve electric control.....	55.17
[55.036] Hydraulic system control.....	55.18
[55.051] Cab Heating, Ventilation, and Air-Conditioning (HVAC) controls.....	55.19
[55.050] Heating, Ventilation, and Air-Conditioning (HVAC) control system.....	55.20
[55.416] Swing control system.....	55.21
[55.417] Travel control system.....	55.22
[55.518] Wiper and washer system.....	55.23
[55.404] External lighting.....	55.24
[55.514] Cab lighting.....	55.25
[55.408] Warning indicators, alarms, and instruments.....	55.26
[55.992] Anti-theft system.....	55.27
[55.DTC] FAULT CODES.....	55.28
Booms, dippers, and buckets.....	84
[84.910] Boom.....	84.1
[84.912] Dipper arm.....	84.2
[84.100] Bucket.....	84.3

Platform, cab, bodywork, and decals	90
[90.150] Cab	90.1
[90.156] Cab windshield and windows	90.2
[90.120] Mechanically-adjusted operator seat	90.3
[90.100] Engine hood and panels	90.4

caseih.servicemanual.com

caseihservicemanual .cc



INTRODUCTION

caseihservicemanual.com

Contents

INTRODUCTION

Foreword - Important notice regarding equipment servicing	3
Safety rules	4
Safety rules - General information	5
Safety rules - Personal safety	6
Safety rules - Cab protective structure	8
Safety rules - Ecology and the environment	9
Torque - Bolt and nut	10
Torque - Special torque setting	11
Basic instructions - Shop and assembly	14
Hydraulic contamination	16
General specification	17
General specification - Main equipment	21
Weight	28
Dimension	30
Conversion factors	34
Consumables	46
Abbreviation	51
Product identification	54
Product identification - Machine orientation	56

caseihservicemanual.com

Foreword - Important notice regarding equipment servicing

All repair and maintenance work listed in this manual must be carried out only by qualified dealership personnel, strictly complying with the instructions given, and using, whenever possible, the special tools.

Anyone who performs repair and maintenance operations without complying with the procedures provided herein shall be responsible for any subsequent damages.

The manufacturer and all the organizations of its distribution chain, including - without limitation - national, regional, or local dealers, reject any responsibility for damages caused by parts and/or components not approved by the manufacturer, including those used for the servicing or repair of the product manufactured or marketed by the manufacturer. In any case, no warranty is given or attributed on the product manufactured or marketed by the manufacturer in case of damages caused by parts and/or components not approved by the manufacturer.

The manufacturer reserves the right to make improvements in design and changes in specifications at any time without notice and without incurring any obligation to install them on units previously sold. Specifications, descriptions, and illustrative material herein are as accurate as known at time of publication but are subject to change without notice.

In case of questions, refer to your CASE CONSTRUCTION Sales and Service Networks.

caseihservicemanual.cc

Safety rules

Personal safety





This is the safety alert symbol. It is used to alert you to potential personal injury hazards. Obey all safety messages that follow this symbol to avoid possible death or injury.

Throughout this manual you will find the signal words DANGER, WARNING, and CAUTION followed by special instructions. These precautions are intended for the personal safety of you and those working with you.

Read and understand all the safety messages in this manual before you operate or service the machine.

 DANGER indicates a hazardous situation that, if not avoided, will result in death or serious injury.

 WARNING indicates a hazardous situation that, if not avoided, could result in death or serious injury.

 CAUTION indicates a hazardous situation that, if not avoided, could result in minor or moderate injury.

FAILURE TO FOLLOW DANGER, WARNING, AND CAUTION MESSAGES COULD RESULT IN DEATH OR SERIOUS INJURY.

Machine safety

NOTICE: Notice indicates a situation that, if not avoided, could result in machine or property damage.

Throughout this manual you will find the signal word Notice followed by special instructions to prevent machine or property damage. The word Notice is used to address practices not related to personal safety.

Information

NOTE: Note indicates additional information that clarifies steps, procedures, or other information in this manual.

Throughout this manual you will find the word Note followed by additional information about a step, procedure, or other information in the manual. The word Note is not intended to address personal safety or property damage.

Safety rules - General information

Cleaning

Clean the metal parts with cleaning solution that meets the standard and steam cleaning. (except for bearings)

After cleaning, dry well, and inject oil in all parts.

Also inject oil into the bearings after drying.

Inspection

When disassembling parts, check all the parts.

If there are any worn or damaged parts, replace them.

Inspect carefully to prevent initial breakdowns.

Bearing

Replace any loose bearings.

Air dry bearings before installing them.

Needle bearing

When inserting needle bearings, be very careful not to damage them.

Apply grease to the section where the needle bearing will be inserted.

Gear

Check that there is no wear and no damage.

Oil seal, O-ring, gasket

Always install new oil seals, O-rings, and gaskets.

Apply grease to sections where oil seals and O-rings will be inserted.

Shaft

Check that there is no wear and no damage.

Check the bearings and check for damaged oil seals on the shaft.

Service parts

Install CASE CONSTRUCTION genuine service parts.

When placing an order, check the parts catalog. It contains the CASE CONSTRUCTION genuine part numbers.

Any breakdowns arising from the installation of non-genuine parts are not covered by the warranty.

Lubricants (fuel, hydraulic oil)

Use the oil from the specified company or specified in the operator's manual or service Manual.

Any breakdowns arising from any fuel or hydraulic oil other than those specified are not covered by the warranty.

Safety rules - Personal safety

 **WARNING:**

This symbol indicates a precaution.
It gives information concerning the safety of the operator and those in the surroundings.
Read and understand these precautions thoroughly before performing the work.

Always comply with warnings and precautions so as to avoid any accidents.

This section covers information related to overall safety.

Check whether all warning labels are in place.

Additional labels can be ordered from Service Parts.

 **WARNING:**

Read the operator's manual to gain a thorough understanding of machine control operations.

 **WARNING:**

Perform any machine operations from the seating position.
Any other method may cause severe injuries.

 **WARNING:**

Only the one operator is to ride on the machine. No one else is to ride on it.

 **WARNING:**

Check the safety messages in the operator's manual before starting the engine.
Check all the warning labels on the machine.
Check that no one is within the machine's operating range.
Check the operating methods in a safe location before starting the actual work.
Understand the machine operations well, then operate in compliance with all service-related laws and regulations.
The operator's manual can be purchased at your CASE CONSTRUCTION dealer.

 **WARNING:**

Working with sloppy clothes or clothes with which safety cannot be ensured leads to damage to the machine and injury to the operator.
Always wear clothes that ensures safety.
In order to work more safely, it is recommended to wear additional safety equipment.
Helmet, safety shoes, ear protection, goggles, work clothes, and gloves

 **WARNING:**

Pay careful attention when working with the engine running.

 **WARNING:**

Check hydraulic equipment.
Work according to the procedure.
Do not change the procedure.

INTRODUCTION



WARNING:

Check that there is no one in the surroundings before draining the pressure from hydraulic circuits during machine hydraulic cylinder inspection.



WARNING:

Use gloves when handling high-temperature parts.



WARNING:

Bring the lower parts or attachments in contact with the ground before inspecting or repairing them.



WARNING:

Check that hoses and tubes are securely connected.
If there is any damage to a hose or tube, replace it.
Do not check for oil leaks by hand. Use cardboard or wood.



WARNING:

When removing an attachment pin or other hardened pin, use a hammer that has a soft head.



WARNING:

Wear eye protection when using a hammer to install a pin or when working with a grinder.
At this time, use goggles or eye protectors that meet standards.



WARNING:

Park the machine in a safe location when repairing or inspecting it.



WARNING:

Use work site protection when repairing the machine.
Check the oil, coolant, grease, and tools.
Recover materials and parts as necessary.
Pay enough attention to safety.



WARNING:

Some of the machine's parts are extremely heavy.
Use an appropriate lifting equipment for such parts.
For weights and procedures, see the Service Manual.



WARNING:

Exhaust gases are toxic.
Always provide good ventilation when working indoors or in any other enclosed space.



WARNING:

If the electrolytic battery solution freezes, it may explode.

Safety rules - Cab protective structure

Cab protective structure

Modifying the cab main components is prohibited in order to protect the operator.

Prohibited items

- Modifications that reduce the strength of a platform that has a cab with a protective structure mounted on it. (Actions or modifications that reduce the functionality of the anchoring part at the left-rear of the cab)
- Modifications that effect the strength of the cab with a protective structure.

Modifications prohibited (red part)	All modifications (grinding, welding, drilling holes, removing, etc.) are prohibited.
Modifications permitted under conditions (gray part)	Removal of parts is prohibited. Bar welding and making holes (up to diameter 20 mm (0.787 in)) by drilling are possible.

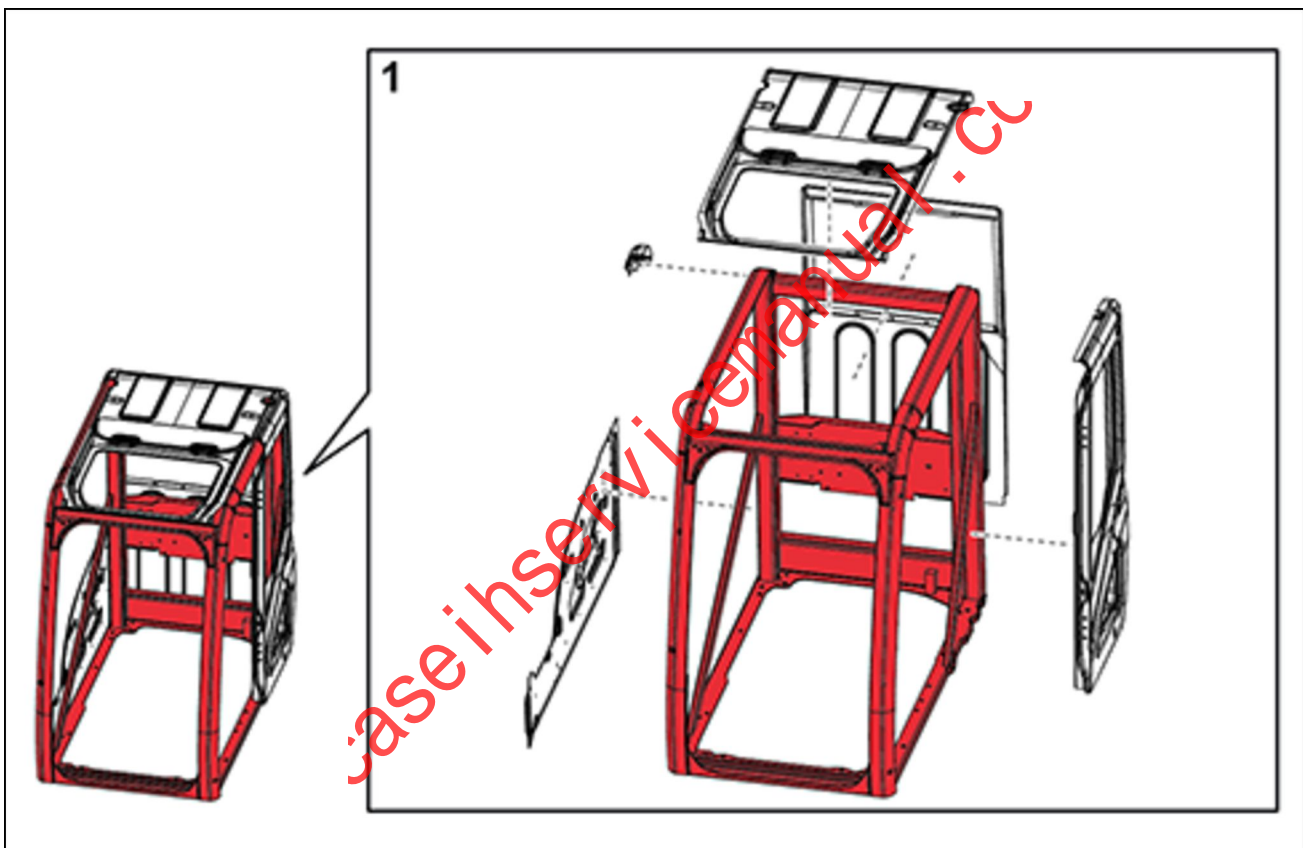

SMPH15CEX6544FA 1

Safety rules - Ecology and the environment

Soil, air, and water quality is important for all industries and life in general. When legislation does not yet rule the treatment of some of the substances that advanced technology requires, sound judgment should govern the use and disposal of products of a chemical and petrochemical nature.

Familiarize yourself with the relative legislation applicable to your country, and make sure that you understand this legislation. Where no legislation exists, obtain information from suppliers of oils, filters, batteries, fuels, anti-freeze, cleaning agents, etc., with regard to the effect of these substances on man and nature and how to safely store, use, and dispose of these substances.

Helpful hints

- Avoid the use of cans or other inappropriate pressurized fuel delivery systems to fill tanks. Such delivery systems may cause considerable spillage.
- In general, avoid skin contact with all fuels, oils, acids, solvents, etc. Most of these products contain substances that may be harmful to your health.
- Modern oils contain additives. Do not burn contaminated fuels and or waste oils in ordinary heating systems.
- Avoid spillage when you drain fluids such as used engine coolant mixtures, engine oil, hydraulic fluid, brake fluid, etc. Do not mix drained brake fluids or fuels with lubricants. Store all drained fluids safely until you can dispose of the fluids in a proper way that complies with all local legislation and available resources.
- Do not allow coolant mixtures to get into the soil. Collect and dispose of coolant mixtures properly.
- The air-conditioning system contains gases that should not be released into the atmosphere. Consult an air-conditioning specialist or use a special extractor to recharge the system properly.
- Repair any leaks or defects in the engine cooling system or hydraulic system immediately.
- Do not increase the pressure in a pressurized circuit as this may lead to a component failure.
- Protect hoses during welding. Penetrating weld splatter may burn a hole or weaken hoses, allowing the loss of oils, coolant, etc.

Battery recycling

Batteries and electric accumulators contain several substances that can have a harmful effect on the environment if the batteries are not properly recycled after use. Improper disposal of batteries can contaminate the soil, groundwater, and waterways. CASE CONSTRUCTION strongly recommends that you return all used batteries to a CASE CONSTRUCTION dealer, who will dispose of the used batteries or recycle the used batteries properly. In some countries, this is a legal requirement.



Mandatory battery recycling

NOTE: The following requirements are mandatory in Brazil.

Batteries are made of lead plates and a sulfuric acid solution. Because batteries contain heavy metals such as lead, CONAMA Resolution 401/2008 requires you to return all used batteries to the battery dealer when you replace any batteries. Do not dispose of batteries in your household garbage.

Points of sale are obliged to:

- Accept the return of your used batteries
- Store the returned batteries in a suitable location
- Send the returned batteries to the battery manufacturer for recycling

Torque - Bolt and nut

- Tighten alternating between left and right and top and bottom so that uniform tightening force is applied.

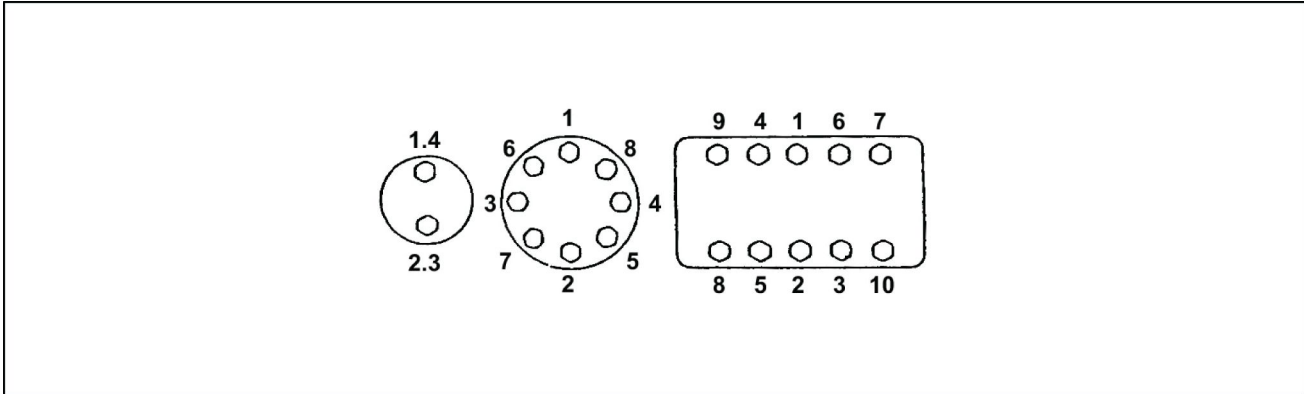

LPIL12CX00005EA 1

- If **LOCTITE®** was used on a removed bolt (there is something white sticking to the bolt when it is removed), clean the old **LOCTITE®** off with cleaning fluid, dry the bolt, then apply 2 - 3 drops of **LOCTITE®** to the thread section of the bolt.

Torque table

Bolt nominal diameter (size)		M6	M8	M10	M12	M14	M16	M18	M20
Hexagon bolt	Wrench	10 mm	13 mm	17 mm	19 mm	22 mm	24 mm	27 mm	30 mm
	Tightening torque	6.9 N·m (5.089 lb ft)	19.6 N·m (14.456 lb ft)	39.2 N·m (28.912 lb ft)	58.8 N·m (43.369 lb ft)	98.1 N·m (72.355 lb ft)	156.9 N·m (115.72 lb ft)	196.1 N·m (144.63 lb ft)	294.2 N·m (216.99 lb ft)
Hexagon socket head bolt	Wrench	5 mm	6 mm	8 mm	10 mm	12 mm	14 mm	14 mm	17 mm
	Tightening torque	8.8 N·m (6.491 lb ft)	21.6 N·m (15.931 lb ft)	42.1 N·m (31.051 lb ft)	78.5 N·m (57.899 lb ft)	117.7 N·m (86.811 lb ft)	176.5 N·m (130.18 lb ft)	245.2 N·m (180.85 lb ft)	343.2 N·m (253.13 lb ft)

Torque - Special torque setting

Code	Retightening location		Nominal bolt diameter	Wrench	Tightening torque
1*	Travel motor		M27	41 mm	1350 - 1580 N·m (996 - 1165 lb ft)
2*	Drive sprocket		M27	41 mm	1307 - 1526 N·m (964 - 1126 lb ft)
3*	Take-up roller		M20	24 mm	1307 - 1526 N·m (964 - 1126 lb ft)
4*	Upper roller		M20	30 mm	521 - 608 N·m (384.27 - 448.44 lb ft)
5*	Lower roller		M27	41 mm	1307 - 1526 N·m (964 - 1126 lb ft)
6*	Track guard		M27	41 mm	1307 - 1526 N·m (964 - 1126 lb ft)
7	Shoe		M27	41 mm	1588 - 1869 N·m (1171 - 1379 lb ft)
8	Counterweight		M42	50 mm	1862 - 2058 N·m (1373.34 - 1517.90 lb ft)
9*	Turntable bearing		M30	36 mm	952 - 1050 N·m (702.16 - 774.44 lb ft)
10*	Swing unit		M24	36 mm	900 - 1050 N·m (663.81 - 774.44 lb ft)
11*	Engine	Mount	M24	41 mm	843.4 - 980.7 N·m (622 - 723 lb ft)
12*		Front support	M14	17 mm	63.8 - 73.6 N·m (47 - 54 lb ft)
13*	Radiator		M20	24 mm	147.2 - 176.6 N·m (109 - 130 lb ft)
14*	Hydraulic pump	Plate	M12	19 mm	88 - 108 N·m (65 - 80 lb ft)
15*		Pump	M24	17 mm hexagon socket head	367 - 496 N·m (270.69 - 365.83 lb ft)
16*	Hydraulic tank		M20	24 mm	225.6 - 264.8 N·m (166 - 195 lb ft)
17*	Fuel tank		M20	24 mm	232.4 - 276 N·m (171 - 204 lb ft)
18*	Control valve		M20	30 mm	333 - 392 N·m (245.61 - 289.12 lb ft)
19*	Center joint	Lock bar	M16	24 mm	267 - 312 N·m (196.93 - 230.12 lb ft)
20*		Joint	M12	19 mm	109 - 127 N·m (80.39 - 93.67 lb ft)
21	Cab		M16	24 mm	149 - 173 N·m (109.90 - 127.60 lb ft)
22	Battery		M10	17 mm	19.6 - 29.4 N·m (14.459 - 21.688 lb ft)
23	Lower frame joint		M36	55 mm	2550 - 2942 N·m (1880.78 - 2169.91 lb ft)

NOTE: Make sure to apply **LOCTITE® 262™** or equivalent to the locations with the * mark, and tighten according to the specified torque.

Tighten the bolts and nuts for which the values are not specified in the table above as follows.

Nominal bolt diameter (Size)		M6	M8	M10	M12	M14	M16	M18	M20
Hexagon bolt	Wrench	10 mm	13 mm	17 mm	19 mm	22 mm	24 mm	27 mm	30 mm
	Tightening torque	6.9 N·m	19.6 N·m	39.2 N·m	58.8 N·m	98.1 N·m	156.9 N·m	196.1 N·m	294.2 N·m
Hexagon socket head bolt	Wrench	5 mm	6 mm	8 mm	10 mm	12 mm	14 mm	14 mm	17 mm
	Tightening torque	8.8 N·m	21.6 N·m	42.1 N·m	78.5 N·m	117.7 N·m	176.5 N·m	245.2 N·m	343.2 N·m

INTRODUCTION

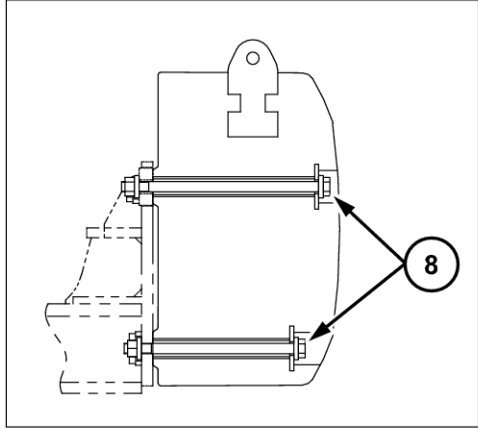
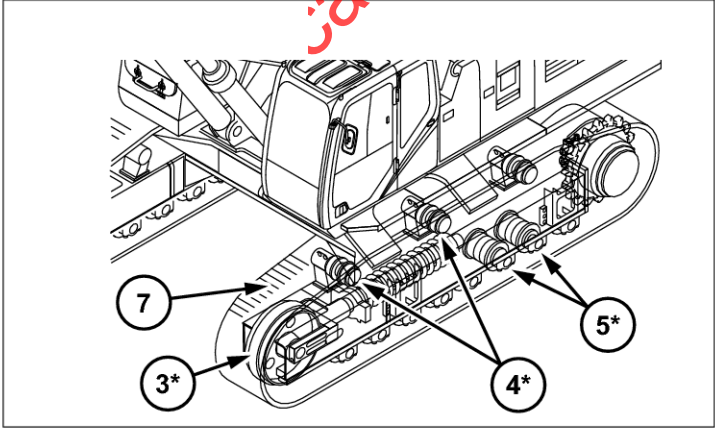
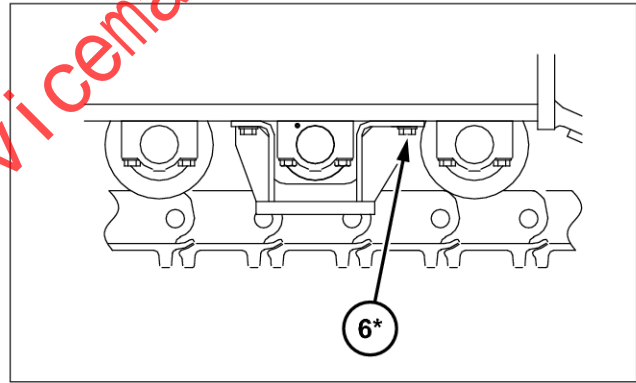
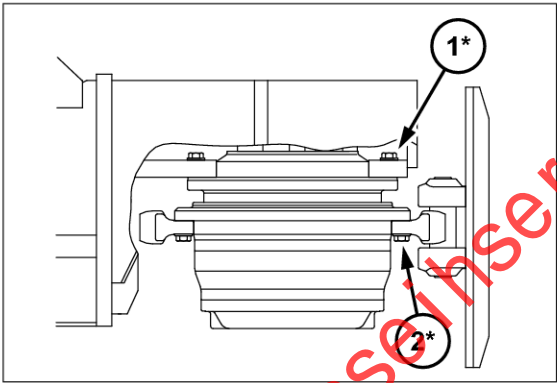
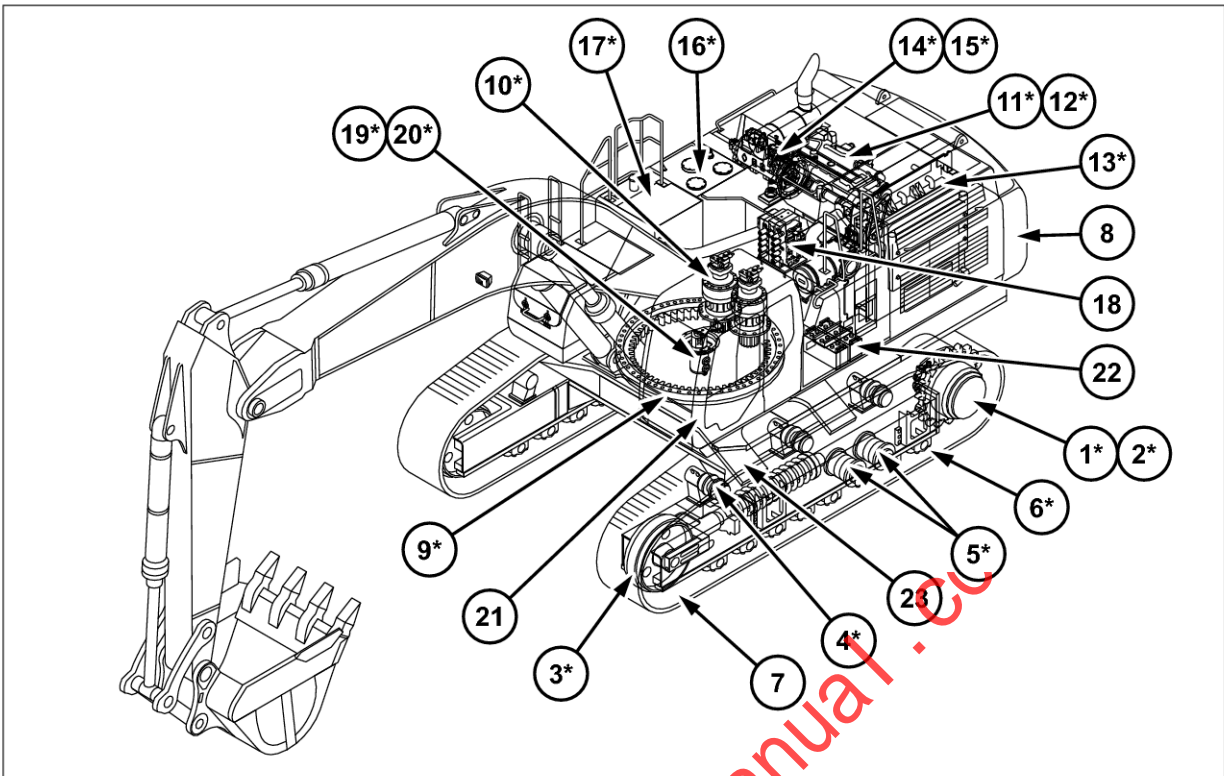

66B91CE4

66B91CE4 1

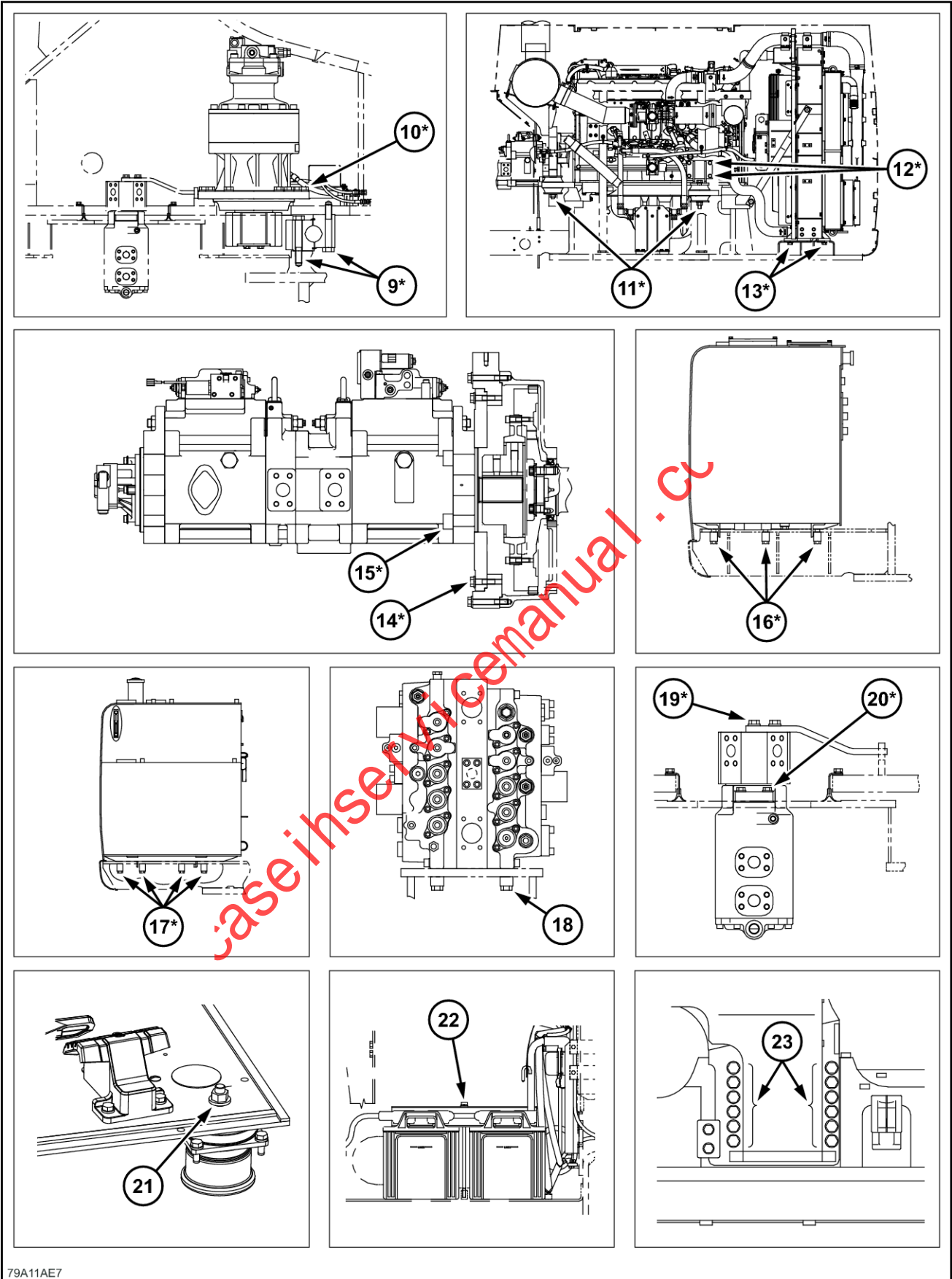

79A11AE7

79A11AE7 2

Basic instructions - Shop and assembly

Shimming

For each adjustment operation, select adjusting shims and measure the adjusting shims individually using a micrometer, then add up the recorded values. Do not rely on measuring the entire shimming set, which may be incorrect, or the rated value shown on each shim.

Rotating shaft seals

For correct rotating shaft seal installation, proceed as follows:

1. Before assembly, allow the seal to soak in the oil it will be sealing for at least thirty minutes.
2. Thoroughly clean the shaft and check that the working surface on the shaft is not damaged.
3. Position the sealing lip facing the fluid.

NOTE: *With hydrodynamic lips, take into consideration the shaft rotation direction and position the grooves so that they will move the fluid towards the inner side of the seal.*

4. Coat the sealing lip with a thin layer of lubricant (use oil rather than grease). Fill the gap between the sealing lip and the dust lip on double lip seals with grease.
5. Insert the seal in its seat and press down using a flat punch or seal installation tool. Do not tap the seal with a hammer or mallet.
6. While you insert the seal, check that the seal is perpendicular to the seat. When the seal settles, make sure that the seal makes contact with the thrust element, if required.
7. To prevent damage to the seal lip on the shaft, position a protective guard during installation operations.

O-ring seals

Lubricate the O-ring seals before you insert them in the seats. This will prevent the O-ring seals from overturning and twisting, which would jeopardize sealing efficiency.

Sealing compounds

Apply a sealing compound on the mating surfaces when specified by the procedure. Before you apply the sealing compound, prepare the surfaces as directed by the product container.

Spare parts

Only use CNH Original Parts or CASE CONSTRUCTION Original Parts.

Only genuine spare parts guarantee the same quality, duration, and safety as original parts, as they are the same parts that are assembled during standard production. Only CNH Original Parts or CASE CONSTRUCTION Original Parts can offer this guarantee.

When ordering spare parts, always provide the following information:

- Machine model (commercial name) and Product Identification Number (PIN)
- Part number of the ordered part, which can be found in the parts catalog

Protecting the electronic and/or electrical systems during charging and welding

To avoid damage to the electronic and/or electrical systems, always observe the following practices:

1. Never make or break any of the charging circuit connections when the engine is running, including the battery connections.
2. Never short any of the charging components to ground.
3. Always disconnect the ground cable from the battery before arc welding on the machine or on any machine attachment.
 - Position the welder ground clamp as close to the welding area as possible.
 - If you weld in close proximity to a computer module, then you should remove the module from the machine.
 - Never allow welding cables to lie on, near, or across any electrical wiring or electronic component while you weld.
4. Always disconnect the negative cable from the battery when charging the battery in the machine with a battery charger.

NOTICE: *If you must weld on the unit, you must disconnect the battery ground cable from the machine battery. The electronic monitoring system and charging system will be damaged if this is not done.*

5. Remove the battery ground cable. Reconnect the cable when you complete welding.

⚠ WARNING

Battery acid causes burns. Batteries contain sulfuric acid.

Avoid contact with skin, eyes or clothing. Antidote (external): Flush with water. Antidote (eyes): flush with water for 15 minutes and seek medical attention immediately. Antidote (internal): Drink large quantities of water or milk. Do not induce vomiting. Seek medical attention immediately. Failure to comply could result in death or serious injury.

W0111A

Special tools

The special tools that CASE CONSTRUCTION suggests and illustrate in this manual have been specifically researched and designed for use with CASE CONSTRUCTION machines. The special tools are essential for reliable repair operations. The special tools are accurately built and rigorously tested to offer efficient and long-lasting operation.

By using these tools, repair personnel will benefit from:

- Operating in optimal technical conditions
- Obtaining the best results
- Saving time and effort
- Working in safe conditions

Hydraulic contamination

Contamination in the hydraulic system is a major cause of the malfunction of hydraulic components. Contamination is any foreign material in the hydraulic oil.

Contamination can enter the hydraulic system in several ways:

- When you drain the oil or disconnect any line
- When you disassemble a component
- From normal wear of the hydraulic components
- From damaged seals or worn seals
- From a damaged component in the hydraulic system

All hydraulic systems operate with some contamination. The design of the components in this hydraulic system permits efficient operation with a small amount of contamination. An increase in this amount of contamination can cause problems in the hydraulic system.

The following list includes some of these problems:

- Cylinder rod seals that leak
- Control valve spools that do not return to neutral
- Movement of control valve spools is difficult
- Hydraulic oil that becomes too hot
- Pump gears, housing, and other parts that wear rapidly
- Relief valves or check valves held open by dirt
- Quick failure of components that have been repaired
- Slow cycle times are slow. The machine does not have enough power.

If your machine has any of these problems, check the hydraulic oil for contamination.

There are two types of contamination: microscopic and visible.

Microscopic contamination occurs when very fine particles of foreign material are suspended in the hydraulic oil. These particles are too small to see or feel. Microscopic contamination can be found by identification of the following problems or by testing in a laboratory.

Examples of problems caused by microscopic contamination:

- Cylinder rod seals that leak
- Control valve spools that do not return to neutral
- The hydraulic system has a high operating temperature

Visible contamination is foreign material that can be found by sight, touch, or odor. Visible contamination can cause a sudden failure of components.

Examples of problems caused by visible contamination:

- Particles of metal or dirt in the oil
- Air in the oil
- Dark or thick oil
- Oil with an odor of burned oil
- Water in the oil

If you find contamination, use a portable filter to clean the hydraulic system.

General specification

Bucket capacity

Bucket capacity 4.5 m³/ISO heaped.

Engine

Type	Water-cooled, 4-cycle diesel, 6-cylinder in line, high pressure common rail system (electric control), turbocharger with air cooled intercooler, without cooling fan	
Model	ISUZU GH-6WG1KYSS-01	
Rated flywheel horse power (ISO 14396)	(without fan-pump)	377.0 kW (512.58 Hp) at 1800 RPM
	(with fan-pump)	349.0 kW (474.51 Hp) at 1800 RPM
Piston displacement	15681 cm³ (957 in³)	
Maximum torque	(ISO 14396)	2031 N·m (1498 lb ft) at 1500 RPM (without fan-pump)
Bore and stroke	147 mm (5.787 in) x 154 mm (6.063 in)	
Voltage	24 V	
Alternator	50 A	
Starter	24 V 7.0 kW	
Cooling system		
Fan	D 1016 mm (40.0 in) with 6-blades	
Radiator capacity	205.7 kW	
	fin type	Corrugated fin (wavy type)
	fin space	2 mm (0.08 in)
Long life coolant	Coolant 55 % , Water 45 %	
Oil cooler capacity	174.4 kW	
	fin type	Plate fin
	fin space	3 mm (0.12 in)
Intercooler capacity	63.3 kW	
	fin type	Straight fin
	fin space	2.0 mm (0.08 in)
Fuel cooler capacity	3.58 kW	
	fin type	Corrugated fin (wavy type)
	fin space	2.25 mm (0.09 in)

Hydraulic system

Main pumps	2 variable displacement axial piston pumps with regulating system	
Max. oil flow	2 × 500 L (105.7 US gal) at 1800 RPM	
Working circuit pressure	Boom (up)/Arm/Bucket	31.4 MPa (4555 psi)
		34.3 MPa (4975 psi) with auto power up
	Swing circuit	26.5 MPa (3844 psi)
	Travel circuit	34.3 MPa (4975 psi)
Pilot pump	1 gear pump	
Max. oil flow	27 L (7.1 US gal)	
Working circuit pressure	4.4 MPa (638 psi)	
Control valves	With Boom/Arm holding valve	
	One 4-spool valve for Right track travel, Bucket, Boom and Arm acceleration	
	One 5-spool valve for Left track travel, Auxiliary, Swing, Boom acceleration and Arm	
Swing device		
Motor	Fixed displacement axial piston motor	
Brake	Mechanical disc brake	