

<https://caseihservicemanual.com>

SRI75 / SVI85
Tier 4B (final)
Alpha Series Skid Steer Loader

SRI75 PIN NDM465633 and above; SVI85 PIN NDM466611 and above

SERVICE MANUAL

Part number 47851947

English
May 2015

Replaces part number 47712041

CASE
CONSTRUCTION



SERVICE MANUAL

SR175 TIER 4B (FINAL) [NDM465633 -]
SV185 TIER 4B (FINAL) [NDM466611 -]

<https://caseih.servicemanual.com>

Link Product / Engine

| Product | Market Product | Engine |
|------------------------------------|----------------|---------------|
| SR175 TIER 4B Final [NDM465633 -] | North America | N4LDI-TA-50SL |
| SV185 TIER 4B Final [NDM466611 -] | North America | N4LDI-TA-45SL |

<https://caseih.servicemanual.com>

Contents

INTRODUCTION

| | |
|---|------|
| Engine..... | 10 |
| [10.001] Engine and crankcase | 10.1 |
| [10.400] Engine cooling system | 10.2 |
| [10.414] Fan and drive | 10.3 |
| Power coupling..... | 19 |
| [19.121] Pump-drive assembly | 19.1 |
| Front axle system | 25 |
| [25.450] Chain drive system..... | 25.1 |
| Rear axle system..... | 27 |
| [27.650] Chain drive system..... | 27.1 |
| Hydrostatic drive..... | 29 |
| [29.202] Hydrostatic transmission | 29.1 |
| [29.134] Two-speed assembly..... | 29.2 |
| [29.200] Mechanical control | 29.3 |
| [29.218] Pump and motor components..... | 29.4 |
| Brakes and controls | 33 |
| [33.110] Parking brake or parking lock | 33.1 |
| Hydraulic systems..... | 35 |
| [35.000] Hydraulic systems..... | 35.1 |
| [35.104] Fixed displacement pump..... | 35.2 |
| [35.300] Reservoir, cooler, and filters..... | 35.3 |
| [35.359] Main control valve..... | 35.4 |
| [35.525] Auxiliary hydraulic valves and lines | 35.5 |
| [35.600] High flow hydraulics..... | 35.6 |
| [35.701] Front loader arm hydraulic system | 35.7 |

| | |
|--|-----------|
| [35.724] Front loader hydraulic system control | 35.8 |
| [35.734] Tool quick coupler hydraulic system | 35.9 |
| Frames and ballasting | 39 |
| [39.140] Ballasts and supports | 39.1 |
| Wheels | 44 |
| [44.511] Front wheels..... | 44.1 |
| [44.520] Rear wheels..... | 44.2 |
| Cab climate control | 50 |
| [50.100] Heating..... | 50.1 |
| [50.200] Air conditioning | 50.2 |
| Electrical systems | 55 |
| [55.000] Electrical system | 55.1 |
| [55.011] Fuel tank system | 55.2 |
| [55.012] Engine cooling system | 55.3 |
| [55.014] Engine intake and exhaust system..... | 55.4 |
| [55.019] Hydrostatic drive control system..... | 55.5 |
| [55.031] Parking brake electrical system | 55.6 |
| [55.036] Hydraulic system control | 55.7 |
| [55.050] Heating, Ventilation, and Air-Conditioning (HVAC) control system..... | 55.8 |
| [55.100] Harnesses and connectors..... | 55.9 |
| [55.302] Battery..... | 55.10 |
| [55.408] Warning indicators, alarms, and instruments | 55.11 |
| [55.512] Cab controls..... | 55.12 |
| [55.640] Electronic modules..... | 55.13 |
| [55.DTC] FAULT CODES..... | 55.14 |
| Front loader and bucket..... | 82 |
| [82.100] Arm..... | 82.1 |
| [82.300] Bucket..... | 82.2 |

| | |
|---|------|
| Platform, cab, bodywork, and decals | 90 |
| [90.150] Cab..... | 90.1 |
| [90.154] Cab doors and hatches | 90.2 |

<https://caseihservicemanual.com>

<https://caseihservicemanual.com>



INTRODUCTION

<https://caseihservicemanual.com>

Contents

INTRODUCTION

| | |
|---|----|
| Foreword - Important notice regarding equipment servicing (*) | 3 |
| Safety rules (*) | 4 |
| Safety rules - Personal safety (*) | 5 |
| Safety rules - Ecology and the environment (*) | 6 |
| Safety rules (*) | 7 |
| Torque - Minimum tightening torques for normal assembly (*) | 8 |
| Torque - Standard torque data for hydraulics (*) | 13 |
| Basic instructions - Shop and assembly (*) | 15 |
| Hydraulic contamination – Contamination (*) | 17 |
| General specification - Left-hand instrument cluster (*) | 18 |
| General specification - Electronic Instrument Cluster (EIC) (*) | 20 |
| General specification - Advanced Instrument Cluster (AIC) (*) | 25 |
| General specification - Biodiesel fuels (*) | 30 |
| Capacities (*) | 33 |
| Product identification | 34 |
| Product identification - Machine orientation (*) | 36 |

<https://caseinstrumentsmanual.com>

(*) See content for specific models

Foreword - Important notice regarding equipment servicing

| | |
|-------|--|
| SR175 | |
| SV185 | |

All repair and maintenance work listed in this manual must be carried out only by qualified dealership personnel, strictly complying with the instructions given, and using, whenever possible, the special tools.

Anyone who performs repair and maintenance operations without complying with the procedures provided herein shall be responsible for any subsequent damages.

The manufacturer and all the organizations of its distribution chain, including - without limitation - national, regional, or local dealers, reject any responsibility for damages caused by parts and/or components not approved by the manufacturer, including those used for the servicing or repair of the product manufactured or marketed by the manufacturer. In any case, no warranty is given or attributed on the product manufactured or marketed by the manufacturer in case of damages caused by parts and/or components not approved by the manufacturer.

The manufacturer reserves the right to make improvements in design and changes in specifications at any time without notice and without incurring any obligation to install them on units previously sold. Specifications, descriptions, and illustrative material herein are as accurate as known at time of publication but are subject to change without notice.

In case of questions, refer to your CASE CONSTRUCTION Sales and Service Networks.

<https://caseih.servicemanual.com>

Safety rules

| | |
|-------|--|
| SR175 | |
| SV185 | |

Personal safety



This is the safety alert symbol. It is used to alert you to potential personal injury hazards. Obey all safety messages that follow this symbol to avoid possible death or injury.

Throughout this manual you will find the signal words DANGER, WARNING, and CAUTION followed by special instructions. These precautions are intended for the personal safety of you and those working with you.

Read and understand all the safety messages in this manual before you operate or service the machine.

! DANGER indicates a hazardous situation that, if not avoided, will result in death or serious injury.

! WARNING indicates a hazardous situation that, if not avoided, could result in death or serious injury.

! CAUTION indicates a hazardous situation that, if not avoided, could result in minor or moderate injury.

FAILURE TO FOLLOW DANGER, WARNING, AND CAUTION MESSAGES COULD RESULT IN DEATH OR SERIOUS INJURY.

Machine safety

NOTICE: Notice indicates a situation that, if not avoided, could result in machine or property damage.

Throughout this manual you will find the signal word Notice followed by special instructions to prevent machine or property damage. The word Notice is used to address practices not related to personal safety.

Information

NOTE: Note indicates additional information that clarifies steps, procedures, or other information in this manual.

Throughout this manual you will find the word Note followed by additional information about a step, procedure, or other information in the manual. The word Note is not intended to address personal safety or property damage.

Safety rules - Personal safety

| | |
|-------|--|
| SR175 | |
| SV185 | |

Carefully study these precautions, and those included in the external attachment operators manual, and insist that they be followed by those working with and for you.

1. Thoroughly read and understand this manual and the attachment Operator's Manual before operating this or any other equipment.
2. Be sure all people and pets are clear of the machine before starting. Sound the horn, if equipped, three times before starting engine.
3. Only the operator should be on the machine when in operation. Never allow anyone to climb on to the machine while it is in motion. If the machine is equipped with an Instructors Seat, this must only be used for training purposes. Passengers must not be allowed to use the Instructors Seat.
4. Keep all shields in place. Never work around the machine or any of the attachments while wearing loose clothing that might catch on moving parts.
5. Observe the following precautions whenever lubricating the machine or making adjustments.
 - Disengage all clutching levers or switches.
 - Lower the attachment, if equipped, to the ground or raise the attachment completely and engage the cylinder safety locks. Completing these actions will prevent the attachment from lowering unexpectedly.
 - Engage the parking brake.
 - Shut off the engine and remove the key.
 - Wait for all machine movement to stop before leaving the operators platform.
6. Always keep the machine in gear while travelling downhill.
7. The machine should always be equipped with sufficient front or rear axle weight for safe operation.
8. Under some field conditions, more weight may be required at the front or rear axle for adequate stability. This is especially important when operating in hilly conditions or/when using heavy attachments.
9. Always lower the attachment, shut off the engine, set the parking brake, engage the transmission gears, remove the key and wait for all machine movement to stop before leaving the operators platform.
10. If the attachment or machine should become obstructed or plugged; set the parking brake, shut off the engine and remove the key, engage the transmission gears, wait for all machine or attachment motion to come to a stop, before leaving the operators platform to removing the obstruction or plug.
11. Never disconnect or make any adjustments to the hydraulic system unless the machine and/or the attachment is lowered to the ground or the safety lock(s) is in the engaged position.
12. Use of the flashing lights is highly recommended when operating on a public road.
13. When transporting on a road or highway, use accessory lights and devices for adequate warning to the operators of other vehicles. In this regard, check local government regulations. Various safety lights and devices are available from your CASE CONSTRUCTION dealer.
14. Practice safety 365 days a year.
15. Keep all your equipment in safe operating condition.
16. Keep all guards and safety devices in place.
17. Always set the parking brake, shut off the engine and remove the key, engage the transmission gears, wait for all machine or attachment motion to come to a stop, before leaving the operators platform to service the machine and attachment.
18. Remember: A careful operator is the best insurance against an accident.
19. Extreme care should be taken in keeping hands and clothing away from moving parts.

Safety rules - Ecology and the environment

| | |
|-------|--|
| SR175 | |
| SV185 | |

Soil, air, and water quality is important for all industries and life in general. When legislation does not yet rule the treatment of some of the substances that advanced technology requires, sound judgment should govern the use and disposal of products of a chemical and petrochemical nature.

Familiarize yourself with the relative legislation applicable to your country, and make sure that you understand this legislation. Where no legislation exists, obtain information from suppliers of oils, filters, batteries, fuels, anti-freeze, cleaning agents, etc., with regard to the effect of these substances on man and nature and how to safely store, use, and dispose of these substances.

Helpful hints

- Avoid the use of cans or other inappropriate pressurized fuel delivery systems to fill tanks. Such delivery systems may cause considerable spillage.
- In general, avoid skin contact with all fuels, oils, acids, solvents, etc. Most of these products contain substances that may be harmful to your health.
- Modern oils contain additives. Do not burn contaminated fuels and or waste oils in ordinary heating systems.
- Avoid spillage when you drain fluids such as used engine coolant mixtures, engine oil, hydraulic fluid, brake fluid, etc. Do not mix drained brake fluids or fuels with lubricants. Store all drained fluids safely until you can dispose of the fluids in a proper way that complies with all local legislation and available resources.
- Do not allow coolant mixtures to get into the soil. Collect and dispose of coolant mixtures properly.
- The air-conditioning system contains gases that should not be released into the atmosphere. Consult an air-conditioning specialist or use a special extractor to recharge the system properly.
- Repair any leaks or defects in the engine cooling system or hydraulic system immediately.
- Do not increase the pressure in a pressurized circuit as this may lead to a component failure.
- Protect hoses during welding. Penetrating weld splatter may burn a hole or weaken hoses, allowing the loss of oils, coolant, etc.

Battery recycling

Batteries and electric accumulators contain several substances that can have a harmful effect on the environment if the batteries are not properly recycled after use. Improper disposal of batteries can contaminate the soil, groundwater, and waterways. CASE CONSTRUCTION strongly recommends that you return all used batteries to a CASE CONSTRUCTION dealer, who will dispose of the used batteries or recycle the used batteries properly. In some countries, this is a legal requirement.



Mandatory battery recycling

NOTE: The following requirements are mandatory in Brazil.

Batteries are made of lead plates and a sulfuric acid solution. Because batteries contain heavy metals such as lead, CONAMA Resolution 401/2008 requires you to return all used batteries to the battery dealer when you replace any batteries. Do not dispose of batteries in your household garbage.

Points of sale are obliged to:

- Accept the return of your used batteries
- Store the returned batteries in a suitable location
- Send the returned batteries to the battery manufacturer for recycling

Safety rules

| | |
|-------|----|
| SR175 | NA |
| SV185 | NA |

CALIFORNIA PROPOSITION 65 WARNING

Diesel engine exhaust and some of its constituents are known to the State of California to cause cancer, birth defects, and other reproductive harm.

Battery post, terminals and related accessories contain lead and lead compounds.

Wash hands after handling

BT09A213 1

<https://caseihservicemanual.com>

Torque - Minimum tightening torques for normal assembly

| | |
|-------|--|
| SR175 | |
| SV185 | |

METRIC NON-FLANGED HARDWARE

| NOM. SIZE | CLASS 8.8 BOLT and CLASS 8 NUT | | CLASS 10.9 BOLT and CLASS 10 NUT | | LOCKNUT CL.8 W/CL8.8 BOLT | LOCKNUT CL.10 W/CL10.9 BOLT |
|-----------|--------------------------------|---------------------|----------------------------------|----------------------|---------------------------|-----------------------------|
| | UNPLATED | PLATED W/ZnCr | UNPLATED | PLATED W/ZnCr | | |
| M4 | 2.2 N·m (19 lb in) | 2.9 N·m (26 lb in) | 3.2 N·m (28 lb in) | 4.2 N·m (37 lb in) | 2 N·m (18 lb in) | 2.9 N·m (26 lb in) |
| M5 | 4.5 N·m (40 lb in) | 5.9 N·m (52 lb in) | 6.4 N·m (57 lb in) | 8.5 N·m (75 lb in) | 4 N·m (36 lb in) | 5.8 N·m (51 lb in) |
| M6 | 7.5 N·m (66 lb in) | 10 N·m (89 lb in) | 11 N·m (96 lb in) | 15 N·m (128 lb in) | 6.8 N·m (60 lb in) | 10 N·m (89 lb in) |
| M8 | 18 N·m (163 lb in) | 25 N·m (217 lb in) | 26 N·m (234 lb in) | 35 N·m (311 lb in) | 17 N·m (151 lb in) | 24 N·m (212 lb in) |
| M10 | 37 N·m (27 lb ft) | 49 N·m (36 lb ft) | 52 N·m (38 lb ft) | 70 N·m (51 lb ft) | 33 N·m (25 lb ft) | 48 N·m (35 lb ft) |
| M12 | 64 N·m (47 lb ft) | 85 N·m (63 lb ft) | 91 N·m (67 lb ft) | 121 N·m (90 lb ft) | 58 N·m (43 lb ft) | 83 N·m (61 lb ft) |
| M16 | 158 N·m (116 lb ft) | 210 N·m (155 lb ft) | 225 N·m (166 lb ft) | 301 N·m (222 lb ft) | 143 N·m (106 lb ft) | 205 N·m (151 lb ft) |
| M20 | 319 N·m (235 lb ft) | 425 N·m (313 lb ft) | 440 N·m (325 lb ft) | 587 N·m (433 lb ft) | 290 N·m (214 lb ft) | 400 N·m (295 lb ft) |
| M24 | 551 N·m (410 lb ft) | 735 N·m (500 lb ft) | 762 N·m (560 lb ft) | 1016 N·m (750 lb ft) | 501 N·m (370 lb ft) | 693 N·m (510 lb ft) |

NOTE: M4 through M8 hardware torque specifications are shown in pound-inches. M10 through M24 hardware torque specifications are shown in pound-feet.

METRIC FLANGED HARDWARE

| NOM. SIZE | CLASS 8.8 BOLT and CLASS 8 NUT | | CLASS 10.9 BOLT and CLASS 10 NUT | | LOCKNUT CL.8 W/CL8.8 BOLT | LOCKNUT CL.10 W/CL10.9 BOLT |
|-----------|--------------------------------|---------------------|----------------------------------|----------------------|---------------------------|-----------------------------|
| | UNPLATED | PLATED W/ZnCr | UNPLATED | PLATED W/ZnCr | | |
| M4 | 2.4 N·m (21 lb in) | 3.2 N·m (28 lb in) | 3.5 N·m (31 lb in) | 4.6 N·m (41 lb in) | 2.2 N·m (19 lb in) | 3.1 N·m (27 lb in) |
| M5 | 4.9 N·m (43 lb in) | 6.5 N·m (58 lb in) | 7.0 N·m (62 lb in) | 9.4 N·m (83 lb in) | 4.4 N·m (39 lb in) | 6.4 N·m (57 lb in) |
| M6 | 8.3 N·m (73 lb in) | 11 N·m (96 lb in) | 12 N·m (105 lb in) | 16 N·m (141 lb in) | 7.5 N·m (66 lb in) | 11 N·m (96 lb in) |
| M8 | 20 N·m (179 lb in) | 27 N·m (240 lb in) | 29 N·m (257 lb in) | 39 N·m (343 lb in) | 18 N·m (163 lb in) | 27 N·m (240 lb in) |
| M10 | 40 N·m (30 lb ft) | 54 N·m (40 lb ft) | 57 N·m (42 lb ft) | 77 N·m (56 lb ft) | 37 N·m (27 lb ft) | 53 N·m (39 lb ft) |
| M12 | 70 N·m (52 lb ft) | 93 N·m (69 lb ft) | 100 N·m (74 lb ft) | 134 N·m (98 lb ft) | 63 N·m (47 lb ft) | 91 N·m (67 lb ft) |
| M16 | 174 N·m (128 lb ft) | 231 N·m (171 lb ft) | 248 N·m (183 lb ft) | 331 N·m (244 lb ft) | 158 N·m (116 lb ft) | 226 N·m (167 lb ft) |
| M20 | 350 N·m (259 lb ft) | 467 N·m (345 lb ft) | 484 N·m (357 lb ft) | 645 N·m (476 lb ft) | 318 N·m (235 lb ft) | 440 N·m (325 lb ft) |
| M24 | 607 N·m (447 lb ft) | 809 N·m (597 lb ft) | 838 N·m (618 lb ft) | 1118 N·m (824 lb ft) | 552 N·m (407 lb ft) | |

IDENTIFICATION

Metric Hex head and carriage bolts, classes 5.6 and up

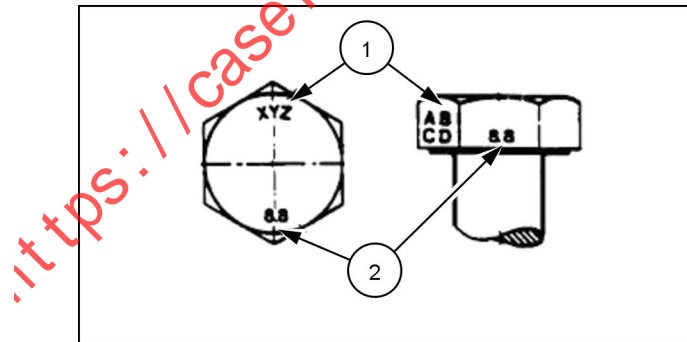

20083680 1

1. Manufacturer's Identification
2. Property Class

Metric Hex nuts and locknuts, classes 05 and up

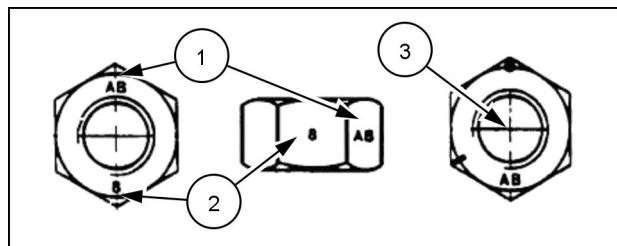

20083681 2

1. Manufacturer's Identification
2. Property Class
3. Clock Marking of Property Class and Manufacturer's Identification (Optional), i.e. marks **60 °** apart indicate Class 10 properties, and marks **120 °** apart indicate Class 8.

INCH NON-FLANGED HARDWARE

| NOMINAL SIZE | SAE GRADE 5 BOLT and NUT | | SAE GRADE 8 BOLT and NUT | | LOCKNUT GrB W/ Gr5 BOLT | LOCKNUT GrC W/ Gr8 BOLT |
|--------------|----------------------------|---------------------|----------------------------|----------------------|-------------------------|-------------------------|
| | UN-PLATED or PLATED SILVER | PLATED W/ZnCr GOLD | UN-PLATED or PLATED SILVER | PLATED W/ZnCr GOLD | | |
| 1/4 | 8 N·m (71 lb in) | 11 N·m (97 lb in) | 12 N·m (106 lb in) | 16 N·m (142 lb in) | 8.5 N·m (75 lb in) | 12.2 N·m (109 lb in) |
| 5/16 | 17 N·m (150 lb in) | 23 N·m (204 lb in) | 24 N·m (212 lb in) | 32 N·m (283 lb in) | 17.5 N·m (155 lb in) | 25 N·m (220 lb in) |
| 3/8 | 30 N·m (22 lb ft) | 40 N·m (30 lb ft) | 43 N·m (31 lb ft) | 57 N·m (42 lb ft) | 31 N·m (23 lb ft) | 44 N·m (33 lb ft) |
| 7/16 | 48 N·m (36 lb ft) | 65 N·m (48 lb ft) | 68 N·m (50 lb ft) | 91 N·m (67 lb ft) | 50 N·m (37 lb ft) | 71 N·m (53 lb ft) |
| 1/2 | 74 N·m (54 lb ft) | 98 N·m (73 lb ft) | 104 N·m (77 lb ft) | 139 N·m (103 lb ft) | 76 N·m (56 lb ft) | 108 N·m (80 lb ft) |
| 9/16 | 107 N·m (79 lb ft) | 142 N·m (105 lb ft) | 150 N·m (111 lb ft) | 201 N·m (148 lb ft) | 111 N·m (82 lb ft) | 156 N·m (115 lb ft) |
| 5/8 | 147 N·m (108 lb ft) | 196 N·m (145 lb ft) | 208 N·m (153 lb ft) | 277 N·m (204 lb ft) | 153 N·m (113 lb ft) | 215 N·m (159 lb ft) |
| 3/4 | 261 N·m (193 lb ft) | 348 N·m (257 lb ft) | 369 N·m (272 lb ft) | 491 N·m (362 lb ft) | 271 N·m (200 lb ft) | 383 N·m (282 lb ft) |
| 7/8 | 420 N·m (310 lb ft) | 561 N·m (413 lb ft) | 594 N·m (438 lb ft) | 791 N·m (584 lb ft) | 437 N·m (323 lb ft) | 617 N·m (455 lb ft) |
| 1 | 630 N·m (465 lb ft) | 841 N·m (620 lb ft) | 890 N·m (656 lb ft) | 1187 N·m (875 lb ft) | 654 N·m (483 lb ft) | 924 N·m (681 lb ft) |

NOTE: For Imperial Units, 1/4 in and 5/16 in hardware torque specifications are shown in pound-inches. 3/8 in through 1 in hardware torque specifications are shown in pound-feet.

INCH FLANGED HARDWARE

| NOM- INAL SIZE | SAE GRADE 5 BOLT and NUT | | SAE GRADE 8 BOLT and NUT | | LOCKNUT GrF W/ Gr5 BOLT | LOCKNUT GrG W/ Gr8 BOLT |
|----------------------|---------------------------------|--------------------------|---------------------------------|--------------------------|-------------------------------|-------------------------------|
| | UNPLATED or PLATED SILVER | PLATED W/ZnCr GOLD | UNPLATED or PLATED SILVER | PLATED W/ZnCr GOLD | | |
| 1/4 | 9 N·m (80 lb in) | 12 N·m (106 lb in) | 13 N·m (115 lb in) | 17 N·m (150 lb in) | 8 N·m (71 lb in) | 12 N·m (106 lb in) |
| 5/16 | 19 N·m (168 lb in) | 25 N·m (221 lb in) | 26 N·m (230 lb in) | 35 N·m (310 lb in) | 17 N·m (150 lb in) | 24 N·m (212 lb in) |
| 3/8 | 33 N·m (25 lb ft) | 44 N·m (33 lb ft) | 47 N·m (35 lb ft) | 63 N·m (46 lb ft) | 30 N·m (22 lb ft) | 43 N·m (32 lb ft) |
| 7/16 | 53 N·m (39 lb ft) | 71 N·m (52 lb ft) | 75 N·m (55 lb ft) | 100 N·m (74 lb ft) | 48 N·m (35 lb ft) | 68 N·m (50 lb ft) |
| 1/2 | 81 N·m (60 lb ft) | 108 N·m (80 lb ft) | 115 N·m (85 lb ft) | 153 N·m (113 lb ft) | 74 N·m (55 lb ft) | 104 N·m (77 lb ft) |
| 9/16 | 117 N·m (86 lb ft) | 156 N·m (115 lb ft) | 165 N·m (122 lb ft) | 221 N·m (163 lb ft) | 106 N·m (78 lb ft) | 157 N·m (116 lb ft) |
| 5/8 | 162 N·m (119 lb ft) | 216 N·m (159 lb ft) | 228 N·m (168 lb ft) | 304 N·m (225 lb ft) | 147 N·m (108 lb ft) | 207 N·m (153 lb ft) |
| 3/4 | 287 N·m (212 lb ft) | 383 N·m (282 lb ft) | 405 N·m (299 lb ft) | 541 N·m (399 lb ft) | 261 N·m (193 lb ft) | 369 N·m (272 lb ft) |
| 7/8 | 462 N·m (341 lb ft) | 617 N·m (455 lb ft) | 653 N·m (482 lb ft) | 871 N·m (642 lb ft) | 421 N·m (311 lb ft) | 594 N·m (438 lb ft) |
| 1 | 693 N·m (512 lb ft) | 925 N·m (682 lb ft) | 979 N·m (722 lb ft) | 1305 N·m (963 lb ft) | 631 N·m (465 lb ft) | 890 N·m (656 lb ft) |

IDENTIFICATION

Inch Bolts and free-spinning nuts

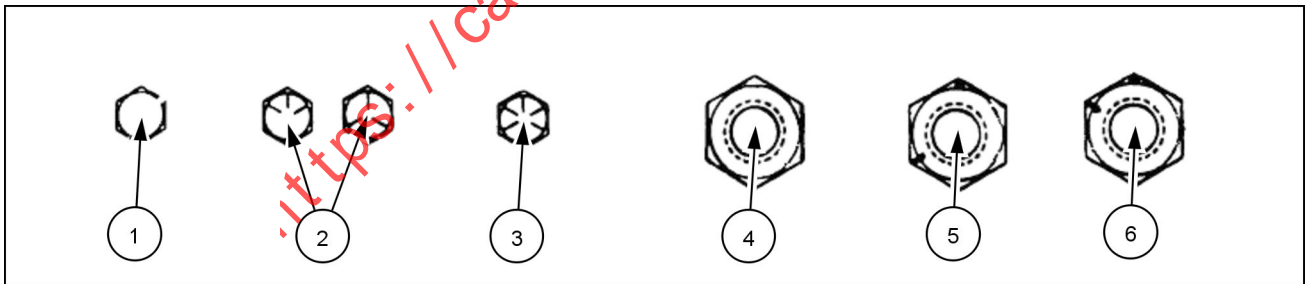

20083682 3

Grade Marking Examples

| SAE Grade Identification | | | |
|--------------------------|-----------------------|---|---------------------------------|
| 1 | Grade 2 - No Marks | 4 | Grade 2 Nut - No Marks |
| 2 | Grade 5 - Three Marks | 5 | Grade 5 Nut - Marks 120 ° Apart |
| 3 | Grade 8 - Five Marks | 6 | Grade 8 Nut - Marks 60 ° Apart |

Inch Lock Nuts, All Metal (Three optional methods)

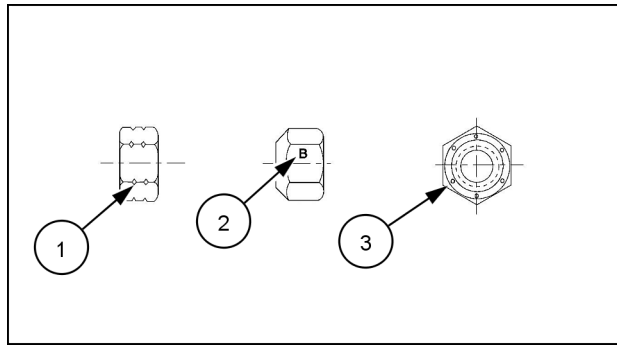

20090268 4

Grade Identification

| Grade | Corner Marking Method (1) | Flats Marking Method (2) | Clock Marking Method (3) |
|---------|-----------------------------|--------------------------|--------------------------|
| Grade A | No Notches | No Mark | No Marks |
| Grade B | One Circumferential Notch | Letter B | Three Marks |
| Grade C | Two Circumferential Notches | Letter C | Six Marks |

<https://caseihservicemanual.com>

Torque - Standard torque data for hydraulics

| | |
|-------|--|
| SR175 | |
| SV185 | |

INSTALLATION OF ADJUSTABLE FITTINGS IN STRAIGHT THREAD O RING BOSSES

1. Lubricate the O-ring by coating it with a light oil or petroleum. Install the O-ring in the groove adjacent to the metal backup washer which is assembled at the extreme end of the groove (4).
2. Install the fitting into the SAE straight thread boss until the metal backup washer contacts the face of the boss (5).

NOTE: Do not over tighten and distort the metal backup washer.

3. Position the fitting by turning out (counterclockwise) up to a maximum of one turn. Holding the pad of the fitting with a wrench, tighten the locknut and washer against the face of the boss (6).

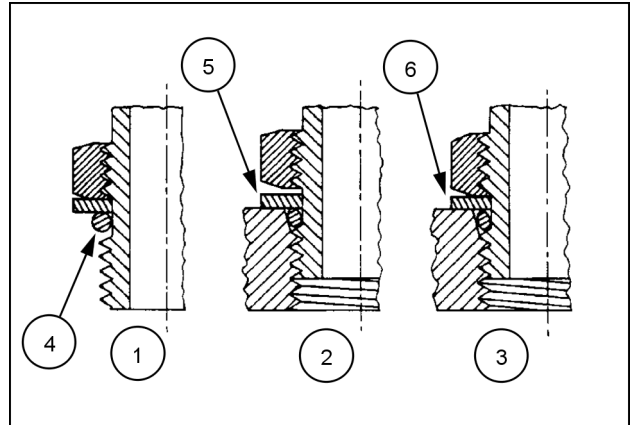

23085659 1

STANDARD TORQUE DATA FOR HYDRAULIC TUBES AND FITTINGS

| TUBE NUTS FOR 37° FLARED FITTINGS | | | | O-RING BOSS PLUGS ADJUSTABLE FITTING LOCKNUTS, SWIVEL JIC- 37° SEATS |
|-----------------------------------|--------------------|-------------|---------------------------------|---|
| SIZE | TUBING OD | THREAD SIZE | TORQUE | TORQUE |
| 4 | 6.4 mm (1/4 in) | 7/16-20 | 12 - 16 N·m (9 - 12 lb ft) | 8 - 14 N·m (6 - 10 lb ft) |
| 5 | 7.9 mm (5/16 in) | 1/2-20 | 16 - 20 N·m (12 - 15 lb ft) | 14 - 20 N·m (10 - 15 lb ft) |
| 6 | 9.5 mm (3/8 in) | 9/16-18 | 29 - 33 N·m (21 - 24 lb ft) | 20 - 27 N·m (15 - 20 lb ft) |
| 8 | 12.7 mm (1/2 in) | 3/4-16 | 47 - 54 N·m (35 - 40 lb ft) | 34 - 41 N·m (25 - 30 lb ft) |
| 10 | 15.9 mm (5/8 in) | 7/8-14 | 72 - 79 N·m (53 - 58 lb ft) | 47 - 54 N·m (35 - 40 lb ft) |
| 12 | 19.1 mm (3/4 in) | 1-1/16-12 | 104 - 111 N·m (77 - 82 lb ft) | 81 - 95 N·m (60 - 70 lb ft) |
| 14 | 22.2 mm (7/8 in) | 1-3/16-12 | 122 - 136 N·m (90 - 100 lb ft) | 95 - 109 N·m (70 - 80 lb ft) |
| 16 | 25.4 mm (1 in) | 1-5/16-12 | 149 - 163 N·m (110 - 120 lb ft) | 108 - 122 N·m (80 - 90 lb ft) |
| 20 | 31.8 mm (1-1/4 in) | 1-5/8-12 | 190 - 204 N·m (140 - 150 lb ft) | 129 - 158 N·m (95 - 115 lb ft) |
| 24 | 38.1 mm (1-1/2 in) | 1-7/8-12 | 217 - 237 N·m (160 - 175 lb ft) | 163 - 190 N·m (120 - 140 lb ft) |
| 32 | 50.8 mm (2 in) | 2-1/2-12 | 305 - 325 N·m (225 - 240 lb ft) | 339 - 407 N·m (250 - 300 lb ft) |

These torques are not recommended for tubes of 12.7 mm (1/2 in) OD and larger with wall thickness of 0.889 mm (0.035 in) or less. The torque is specified for 0.889 mm (0.035 in) wall tubes on each application individually.

Before installing and torquing 37° flared fittings, clean the face of the flare and threads with a clean solvent or Loctite cleaner and apply hydraulic sealant LOCTITE® 569 to the 37° flare and the threads.

Install fitting and torque to specified torque, loosen fitting and retorquing to specifications.

PIPE THREAD FITTING TORQUE

Before installing and tightening pipe fittings, clean the threads with a clean solvent or Loctite cleaner and apply sealant **LOCTITE® 567 PST PIPE SEALANT** for all fittings including stainless steel or **LOCTITE® 565 PST** for most metal fittings. For high filtration/zero contamination systems use **LOCTITE® 545**.

| PIPE THREAD FITTING | |
|---------------------|-------------------|
| Thread Size | Torque (Maximum) |
| 1/8-27 | 13 N·m (10 lb ft) |
| 1/4-18 | 16 N·m (12 lb ft) |
| 3/8-18 | 22 N·m (16 lb ft) |
| 1/2-14 | 41 N·m (30 lb ft) |
| 3/4-14 | 54 N·m (40 lb ft) |

INSTALLATION OF ORFS (O-RING FLAT FACED) FITTINGS

When installing ORFS fittings thoroughly clean both flat surfaces of the fittings **(1)** and lubricate the O-ring **(2)** with light oil. Make sure both surfaces are aligned properly. Torque the fitting to specified torque listed throughout the repair manual.

NOTICE: If the fitting surfaces are not properly cleaned, the O-ring will not seal properly. If the fitting surfaces are not properly aligned, the fittings may be damaged and will not seal properly.

NOTICE: Always use genuine factory replacement oils and filters to ensure proper lubrication and filtration of engine and hydraulic system oils.

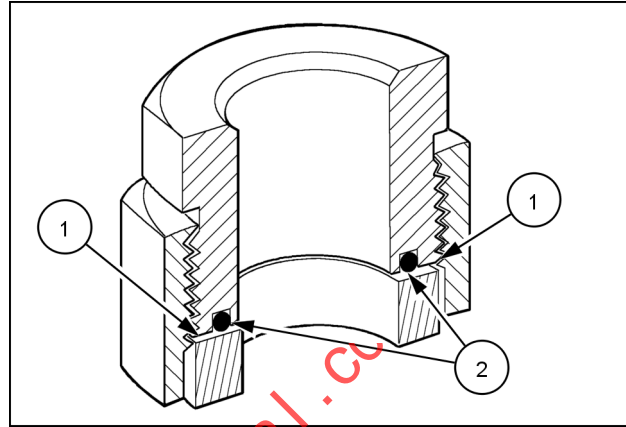

50011183 2

The use of proper oils, grease, and keeping the hydraulic system clean will extend machine and component life.

<https://caseihservicemanual.com>

Basic instructions - Shop and assembly

| | |
|-------|--|
| SR175 | |
| SV185 | |

Shimming

For each adjustment operation, select adjusting shims and measure the adjusting shims individually using a micrometer, then add up the recorded values. Do not rely on measuring the entire shimming set, which may be incorrect, or the rated value shown on each shim.

Rotating shaft seals

For correct rotating shaft seal installation, proceed as follows:

1. Before assembly, allow the seal to soak in the oil it will be sealing for at least thirty minutes.
2. Thoroughly clean the shaft and check that the working surface on the shaft is not damaged.
3. Position the sealing lip facing the fluid.

NOTE: With hydrodynamic lips, take into consideration the shaft rotation direction and position the grooves so that they will move the fluid towards the inner side of the seal.

4. Coat the sealing lip with a thin layer of lubricant (use oil rather than grease). Fill the gap between the sealing lip and the dust lip on double lip seals with grease.
5. Insert the seal in its seat and press down using a flat punch or seal installation tool. Do not tap the seal with a hammer or mallet.
6. While you insert the seal, check that the seal is perpendicular to the seat. When the seal settles, make sure that the seal makes contact with the thrust element, if required.
7. To prevent damage to the seal lip on the shaft, position a protective guard during installation operations.

O-ring seals

Lubricate the O-ring seals before you insert them in the seats. This will prevent the O-ring seals from overturning and twisting, which would jeopardize sealing efficiency.

Sealing compounds

Apply a sealing compound on the mating surfaces when specified by the procedure. Before you apply the sealing compound, prepare the surfaces as directed by the product container.

Spare parts

Only use CNH Original Parts or CASE CONSTRUCTION Original Parts.

Only genuine spare parts guarantee the same quality, duration, and safety as original parts, as they are the same parts that are assembled during standard production. Only CNH Original Parts or CASE CONSTRUCTION Original Parts can offer this guarantee.

When ordering spare parts, always provide the following information:

- Machine model (commercial name) and Product Identification Number (PIN)
- Part number of the ordered part, which can be found in the parts catalog

Protecting the electronic and/or electrical systems during charging and welding

To avoid damage to the electronic and/or electrical systems, always observe the following practices:

1. Never make or break any of the charging circuit connections when the engine is running, including the battery connections.
2. Never short any of the charging components to ground.
3. Always disconnect the ground cable from the battery before arc welding on the machine or on any machine attachment.
 - Position the welder ground clamp as close to the welding area as possible.
 - If you weld in close proximity to a computer module, then you should remove the module from the machine.
 - Never allow welding cables to lie on, near, or across any electrical wiring or electronic component while you weld.
4. Always disconnect the negative cable from the battery when charging the battery in the machine with a battery charger.

NOTICE: *If you must weld on the unit, you must disconnect the battery ground cable from the machine battery. The electronic monitoring system and charging system will be damaged if this is not done.*

5. Remove the battery ground cable. Reconnect the cable when you complete welding.

⚠ WARNING

Battery acid causes burns. Batteries contain sulfuric acid.

Avoid contact with skin, eyes or clothing. Antidote (external): Flush with water. Antidote (eyes): flush with water for 15 minutes and seek medical attention immediately. Antidote (internal): Drink large quantities of water or milk. Do not induce vomiting. Seek medical attention immediately.

Failure to comply could result in death or serious injury.

W0111A

Special tools

The special tools that CASE CONSTRUCTION suggests and illustrate in this manual have been specifically researched and designed for use with CASE CONSTRUCTION machines. The special tools are essential for reliable repair operations. The special tools are accurately built and rigorously tested to offer efficient and long-lasting operation.

By using these tools, repair personnel will benefit from:

- Operating in optimal technical conditions
- Obtaining the best results
- Saving time and effort
- Working in safe conditions

Hydraulic contamination – Contamination

| | |
|-------|--|
| SR175 | |
| SV185 | |

Contamination in the hydraulic system is a major cause of the malfunction of hydraulic components. Contamination is any foreign material in the hydraulic oil. Contamination can enter the hydraulic system in several ways.

1. When you drain the oil or disconnect any line.
2. When you disassemble a component.
3. From normal wear of the hydraulic components.
4. From damaged or worn seals.
5. From a damaged component in the hydraulic system.

All hydraulic systems operate with some contamination. The design of the components in this hydraulic system permits efficient operation with a small amount of contamination. An increase in this amount of contamination can cause problems in the hydraulic system. The following list includes some of these problems.

1. Cylinder rod seals leak.
2. Control valve spools do not return to neutral.
3. Movement of control valve spools is difficult.
4. Hydraulic oil becomes too hot.
5. Pump gears, housing, and other parts wear rapidly.
6. Relief valves or check valves held open by dirt.
7. Quick failure of components that have been repaired.
8. Cycle times are slow; machine does not have enough power.

If your machine has any of these problems, check the hydraulic oil for contamination. See types of contamination below. If you find contamination, use the Portable Filter to clean the hydraulic system.

NOTE: *There are two types of contamination, microscopic and visible.*

Microscopic contamination occurs when very fine particles of foreign material are in suspension in the hydraulic oil.

These particles are too small to see or feel. Microscopic contamination can be found by identification of the following problems or by testing in a laboratory. Examples of the problems:

1. Cylinder rod seal leak.
2. Control valve spools do not return to NEUTRAL.
3. The hydraulic system has a high operating temperature.

Visible contamination is foreign material that can be found by sight, touch, or odor. Visible contamination can cause a sudden failure of components. Examples of visible contamination:

1. Particles of metal or dirt in the oil.
2. Air in the oil.
3. The oil is dark and thick.
4. The oil has an odor of burned oil.
5. Water in the oil.