

<https://caseih.servicemanual.com>

PUMA 165

PUMA 180

PUMA 195

PUMA 210

Tractor with/without Multicontroller

SERVICE MANUAL

Part number 87628095_CNA

English

December 2010

Replaces part number 84225399

CASE IH
AGRICULTURE

Contents

INTRODUCTION

DISTRIBUTION SYSTEMS..... A

PRIMARY HYDRAULIC POWER SYSTEM.....	A.10.A
PRIMARY HYDRAULIC POWER SYSTEM Closed center mechanical remote valve	A.10.B
PRIMARY HYDRAULIC POWER SYSTEM Electro-hydraulic remote valve.....	A.10.C
PRIMARY HYDRAULIC POWER SYSTEM Electro-hydraulic remote valve.....	A.10.C
SECONDARY HYDRAULIC POWER SYSTEM.....	A.12.A
HYDRAULIC COMMAND SYSTEM.....	A.14.A
PNEUMATIC SYSTEM.....	A.20.A
ELECTRICAL POWER SYSTEM.....	A.30.A
ELECTRICAL POWER SYSTEM.....	A.30.A
ELECTRONIC SYSTEM.....	A.50.A
FAULT CODES.....	A.50.A

POWER PRODUCTION..... B

ENGINE.....	B.10.A
FUEL AND INJECTION SYSTEM.....	B.20.A
AIR INTAKE SYSTEM.....	B.30.A
EXHAUST SYSTEM.....	B.40.A
ENGINE COOLANT SYSTEM.....	B.50.A
LUBRICATION SYSTEM.....	B.60.A
STARTING SYSTEM.....	B.80.A

POWER TRAIN..... C

TRANSMISSION Powershift.....	C.20.E
ADDITIONAL REDUCERS Creeper.....	C.30.C
ADDITIONAL REDUCERS Overdrive.....	C.30.D
REAR PTO Mechanical.....	C.40.B
REAR PTO Hydraulic.....	C.40.C
FRONT PTO Hydraulic.....	C.42.C

TRAVELLING..... D

FRONT AXLE	D.10.A
REAR AXLE	D.12.A
2WD-4WD SYSTEM Hydraulic	D.14.C
STEERING Hydraulic	D.20.C
STEERING AutoPilot	D.20.E
SERVICE BRAKE Mechanical	D.30.B
SERVICE BRAKE Hydraulic	D.30.C
SERVICE BRAKE Pneumatic	D.30.E
PARKING BRAKE Mechanical	D.32.B
PARKING BRAKE Electronic	D.32.D
BRAKE CONNECTION Hydraulic	D.34.C
SUSPENSION Hydraulic	D.40.C
WHEELS AND TRACKS Wheels	D.50.C
BODY AND STRUCTURE	E
FRAME Primary frame	E.10.B
USER PLATFORM	E.34.A
ENVIRONMENT CONTROL Heating, ventilation and air-conditioning	E.40.D
WORKING ARM	H
HITCH Front hitch	H.10.B
HITCH Rear hitch	H.10.C
HITCH Electronic draft control	H.10.D
HITCH Electronic draft control	H.10.D

<https://caseihservicemanual.com>



INTRODUCTION

<https://caseihservicemanual.com>

Contents

INTRODUCTION

Safety rules	3
--------------------	---

<https://caseihservicemanual.com>

Safety rules

IMPORTANT NOTICE

All maintenance and repair operations described in this manual should be carried out exclusively by authorised workshops. All instructions should be carefully observed and special equipment where indicated should be used. Anyone who carries out service operations described without carefully observing these instructions will be directly responsible for any damage caused.

NOTES FOR EQUIPMENT

Equipment shown in this manual is:

- designed expressly for use on these tractors;
- necessary to make a reliable repair;
- accurately built and strictly tested to offer efficient and long-lasting working life.

NOTICES

The words "front", "rear", "right hand", and "left hand" refer to the different parts as seen from the operator's seat oriented to the normal direction of movement of the tractor.

SAFETY RULES

PAY ATTENTION TO THIS SYMBOL



This warning symbol points out important messages involving personal safety. Carefully read the safety rules contained herein and follow advised precautions to avoid potential hazards and safeguard your safety. In this manual you will find this symbol together with the following key-words:
 WARNING -it gives warning about improper repair operations and potential consequences affecting the service technician's personal safety.
 DANGER - it gives specific warning about potential dangers for personal safety of the operator or other persons directly or indirectly involved in the operation.



TO PREVENT ACCIDENTS

Most accidents and personal injuries taking place in workshops are due from non-observance of some essential rules and safety precautions.

The possibility that an accident might occur with any type of machines should not be disregarded, no matter how well the machine in question was designed and built.

A wise and careful service technician is the best precautions against accidents.

Careful observance of this basic precaution would be enough to avoid many severe accidents.



DANGER



Never carry out any cleaning, lubrication or maintenance operations when the engine is running.

B013

SAFETY RULES

Generalities

- Carefully follow specified repair and maintenance procedures.

INTRODUCTION

- Do not wear rings, wristwatches, jewels, unbuttoned or flapping clothing such as ties, torn clothes, scarves, open jackets or shirts with open zips which could get caught on moving parts. Use approved safety clothing such as anti-slipping footwear, gloves, safety goggles, helmets, etc.
- Wear safety glasses with side guards when cleaning parts using compressed air.
- Damaged or frayed wires and chains are unreliable. Do not use them for lifting or towing.
- Wear suitable protection such as approved eye protection, helmets, special clothing, gloves and footwear whenever welding. All persons standing in the vicinity of the welding process should wear approved eye protection. NEVER LOOK AT THE WELDING ARC IF YOUR EYES ARE NOT SUITABLY PROTECTED.
- Never carry out any repair on the machine if someone is sitting on the operator's seat, except if they are qualified operators assisting in the operation to be carried out.
- Never operate the machine or use attachments from a place other than sitting at the operator's seat or at the side of the machine when operating the fender switches.
- Never carry out any operation on the machine when the engine is running, except when specifically indicated. Stop the engine and ensure that all pressure is relieved from hydraulic circuits before removing caps, covers, valves, etc.
- All repair and maintenance operations should be carried out with the greatest care and attention.
- Disconnect the batteries and label all controls to warn that the tractor is being serviced. Block the machine and all equipment which should be raised.
- Never check or fill fuel tanks or batteries, nor use starting liquid if you are smoking or near open flames as such fluids are flammable.
- The fuel filling gun should always remain in contact with the filler neck. Maintain this contact until the fuel stops flowing into the tank to avoid possible sparks due to static electricity build-up.
- To transfer a failed tractor, use a trailer or a low loading platform or dolly if available.
- To load and unload the machine from the transportation means, select a flat area providing a firm support to the trailer or truck wheels. Firmly tie the machine to the truck or trailer platform and block wheels as required by the transporter.
- Always use lifting equipment of appropriate capacity to lift or move heavy components.
- Chains should always be safely fastened. Ensure that fastening device is strong enough to hold the load foreseen. No persons should stand near the fastening point.
- The working area should be always kept CLEAN and DRY. Immediately clean any spillage of water or oil.
- Never use gasoline, diesel oil or other flammable liquids as cleaning agents. Use non-flammable non-toxic proprietary solvents.
- Do not pile up grease or oil soaked rags, as they constitute a great fire hazard. Always place them into a metal container.

START UP

- Never run the engine in confined spaces which are not equipped with adequate ventilation for exhaust gas extraction.
- Never bring your head, body, arms, legs, feet, hands, fingers near fans or rotating belts.

ENGINE

- Always loosen the radiator cap very slowly before removing it to allow pressure in the system to dissipate. Coolant should be topped up only when the engine is stopped.
- Do not fill up fuel tank when the engine is running.
- Never adjust the fuel injection pump when the tractor is moving.
- Never lubricate the tractor when the engine is running.

ELECTRICAL SYSTEMS

- If it is necessary to use auxiliary batteries, cables must be connected at both sides as follows: (+) to (+) and (-) to (-). Avoid short-circuiting the terminals. GAS RELEASED FROM BATTERIES IS HIGHLY FLAMMABLE. During

charging, leave the battery compartment uncovered to improve ventilation. Avoid sparks or flames near the battery area. Do no smoke.

- Do not charge batteries in confined spaces.
- Always disconnect the batteries before performing any type of service on the electrical system.

HYDRAULIC SYSTEMS

- Some fluid coming out from a very small port can be almost invisible and be strong enough to penetrate the skin. For this reason, NEVER USE YOUR HANDS TO CHECK FOR LEAKS, but use a piece of cardboard or a piece of wood for this purpose. If any fluid is injected into the skin, seek medical aid immediately. Lack of immediate medical attention may result in serious infections or dermatitis.
- Always take system pressure readings using the appropriate gauges.

WHEELS AND TYRES

- Check that the tyres are correctly inflated at the pressure specified by the manufacturer. Periodically check for possible damage to the rims and tyres.
- Stay at the tyre side when inflating.
- Check the pressure only when the tractor is unloaded and tyres are cold to avoid wrong readings due to over-pressure.
- Never cut, nor weld a rim with the inflated tyre assembled.
- To remove the wheels, block both front and rear tractor wheels. Raise the tractor and install safe and stable supports under the tractor in accordance with regulations in force.
- Deflate the tyre before removing any object caught into the tyre tread.
- Never inflate tyres using flammable gases as they may generate explosions and cause injuries to bystanders.

REMOVAL AND INSTALLATION

- Lift and handle all heavy components using lifting equipment of adequate capacity. Ensure that parts are supported by appropriate slings and hooks. Use lifting eyes provided to this purpose. Take care of the persons near the loads to be lifted.

HEALTH AND SAFETY

CONTENT

Section	Description	Page
	HEALTH AND SAFETY PRECAUTIONS	4
	ACIDS AND ALKALIS	5
	ADHESIVES AND SEALERS - see Fire	5
	ANTIFREEZE - see Fire, Solvents e.g. Isopropanol, Ethylene Glycol, Methanol.	5
	ARC WELDING - see Welding.	5
	BATTERY ACIDS - see Acids and Alkalis.	5
	BRAKE AND CLUTCH FLUIDS (Polyalkylene Glycols) - see Fire.	6
	BRAZING - see Welding.	6
	CHEMICAL MATERIALS - GENERAL - see Legal Aspects.	6
	DO'S.	6
	DO NOTS.	6
	CORROSION PROTECTION MATERIALS - see Solvents, Fire.	6
	DUSTS	7
	ELECTRIC SHOCK.	7
	EXHAUST FUMES.	7
	FIBRE INSULATION - see Dusts.. . . .	7
	FIRE - see Welding, Foams, Legal Aspects.. . . .	7
	FIRST AID.	7
	FOAMS - Polyurethane - see Fire.. . . .	7

FUELS - see Fire, Legal Aspects, Chemicals - General, Solvents..	8
GAS CYLINDERS - see Fire..	8
GENERAL WORKSHOP TOOLS AND EQUIPMENT..	9
LEGAL ASPECTS..	9
LUBRICANTS AND GREASES..	9
PAINTS - see Solvents and Chemical Materials - General..	10
SOLDER - see Welding..	10
SOLVENTS - see Chemical Materials - General Fuels (Kerosene), Fire..	10
SUSPENDED LOADS..	11
WELDING - see Fire, Electric Shock, Gas Cylinders..	11

HEALTH AND SAFETY PRECAUTIONS

Many of the procedures associated with vehicle maintenance and repair involve physical hazards or other risks to health. This section lists, alphabetically, some of these hazardous operations and the materials and equipment associated with them. The precautions necessary to avoid these hazards are identified.

The list is not exhaustive and all operations and procedures and the handling of materials, should be carried out with health and safety in mind.

ACIDS AND ALKALIS

see Battery acids, e.g. caustic soda, sulphuric acid.
Used in batteries and cleaning materials.

Irritant and corrosive to the skin, eyes, nose and throat. Causes burns.

Avoid splashes to the skin, eyes and clothing. Wear suitable protective gloves and goggles. Can destroy ordinary protective clothing. Do not breathe mists.

Ensure access to water and soap is readily available for splashing accidents.

ADHESIVES AND SEALERS

see Fire

Highly Flammable, Flammable, combustible.

Generally should be stored in "No Smoking" areas; cleanliness and tidiness in use should be observed, e.g. disposable paper covering benches; should be dispensed from applicators where possible; containers, including secondary containers, should be labelled.

Solvent based Adhesives/Sealers

See Solvents.

Follow manufacturers instructions.

Water based Adhesives/Sealers

Those based on polymer emulsions and rubber lattices may contain small amounts of volatile toxic and harmful chemicals. Skin and eye contact should be avoided and adequate ventilation provided during use.

Follow manufacturers instructions.

Resin based Adhesives/Sealers

e.g. epoxide and formaldehyde resin based.

Mixing should only be carried out in well ventilated areas as harmful or toxic volatile chemicals may be released.

Skin contact with uncured resins and hardeners can result in irritation; dermatitis and absorption of toxic or harmful chemicals through the skin. Splashes can damage the eyes.

Provide adequate ventilation and avoid skin and eye contact. Follow manufacturers instructions.

Anaerobic, Cyanoacrylate and other Acrylic Adhesives

Many are irritant, sensitizing or harmful to the skin. Some are eye irritants.

Skin and eye contact should be avoided and the manufacturers instructions followed.

Cyanoacrylate adhesives (super-glues) must not contact the skin or eyes. If skin or eye tissue is bonded cover with a clean moist pad and get medical attention. do not attempt to pull tissue apart. Use in well ventilated areas as vapours can cause irritation of the nose and eyes.

For two-pack systems see Resin based adhesives/sealers.

Isocyanate (Polyurethane) Adhesives/ Sealers

see Resin based Adhesives.

Individuals suffering from asthma or respiratory allergies should not work with or near these materials as sensitivity reactions can occur.

Any spraying should preferably be carried out in exhaust ventilated booths removing vapours and spray droplets from the breathing zone. Individuals working with spray applications should wear supplied air respirators.

ANTIFREEZE

see Fire, Solvents e.g. Isopropanol, Ethylene Glycol, Methanol.

Highly Flammable, Flammable, Combustible.

Used in vehicle coolant systems, brake air pressure systems, screenwash solutions.

Vapours given off from coolant antifreeze (glycol) arise only when heated.

Antifreeze may be absorbed through the skin in toxic or harmful quantities. Antifreeze if swallowed is fatal and medical attention must be found immediately.

ARC WELDING

see Welding.

BATTERY ACIDS

see Acids and Alkalis.

Gases released during charging are explosive.

Never use naked flames or allow sparks near charging or recently charged batteries.

BRAKE AND CLUTCH FLUIDS (Polyethylene Glycols)

see Fire.

Combustible.

Splashes to the skin and eyes are slightly irritating.

Avoid skin and eye contact as far as possible.

Inhalation of vapour hazards do not arise at ambient temperatures because of the very low vapour pressure.

BRAZING

see Welding.

CHEMICAL MATERIALS - GENERAL

see Legal Aspects.

Chemical materials such as solvents, sealers, adhesives, paints, resin foams, battery acids, antifreeze, brake fluids, oils and grease should always be used with caution and stored and handled with care. They may be toxic, harmful, corrosive, irritant or highly inflammable and give rise to hazardous fumes and dusts.

The effects of excessive exposure to chemicals may be immediate or delayed; briefly experienced or permanent; cumulative; superficial; life threatening; or may reduce life-expectancy.

DO'S

Do remove chemical materials from the skin and clothing as soon as practicable after soiling. Change heavily soiled clothing and have it cleaned.

Do carefully read and observe hazard and precaution warnings given on material containers (labels) and in any accompanying leaflets, poster or other instructions. Material health and safety data sheets can be obtained from Manufacturers.

Do organise work practices and protective clothing to avoid soiling of the skin and eyes; breathing vapours/aerosols/dusts/fumes; inadequate container labelling; fire and explosion hazards.

Do wash before job breaks; before eating, smoking, drinking or using toilet facilities when handling chemical materials.

Do keep work areas clean, uncluttered and free of spills.

Do store according to national and local regulations.

Do keep chemical materials out of reach of children.

DO NOTS

Do Not mix chemical materials except under the manufacturers instructions; some chemicals can form other toxic or harmful chemicals; give off toxic or harmful fumes; be explosive when mixed together.

Do Not spray chemical materials, particularly those based on solvents, in confined spaces e.g. when people are inside a vehicle.

Do Not apply heat or flame to chemical materials except under the manufacturers' instructions. Some are highly inflammable and some may release toxic or harmful fumes.

Do Not leave containers open. Fumes given off can build up to toxic, harmful or explosive concentrations. Some fumes are heavier than air and will accumulate in confined areas, pits etc.

Do Not transfer chemical materials to unlabeled containers.

Do Not clean hands or clothing with chemical materials. Chemicals, particularly solvents and fuels will dry the skin and may cause irritation with dermatitis. Some can be absorbed through the skin in toxic or harmful quantities.

Do Not use emptied containers for other materials, except when they have been cleaned under supervised conditions.

Do Not sniff or smell chemical materials. Brief exposure to high concentrations of fumes can be toxic or harmful.

Clutch Fluids

see Brake and Clutch Fluids.

Clutch Linings and Pads

see Brake and Clutch Linings and Pads.

CORROSION PROTECTION MATERIALS

see Solvents, Fire.

Highly flammable, flammable.

These materials are varied and the manufacturers instructions should be followed. They may contain solvents, resins, petroleum products etc. Skin and eye contact should be avoided. They should only be sprayed in conditions of adequate ventilation and not in confined spaces.

Cutting

see Welding.

De-Waxing

see Solvents and Fuels (Kerosene).

DUSTS

Powder, dusts or clouds may be irritant, harmful or toxic. Avoid breathing dusts from powdery chemical materials or those arising from dry abrasion operations. Wear respiratory protection if ventilation is inadequate.

ELECTRIC SHOCK

Electric shocks can result from the use of faulty electrical equipment or from the misuse of equipment even in good condition.

Ensure that electrical equipment is maintained in good condition and frequently tested.

Ensure that flexes, cables, plugs and sockets are not frayed, kinked, cut, cracked or otherwise damaged.

Ensure that electric equipment is protected by the correct rated fuse.

Never misuse electrical equipment and never use equipment which is in any way faulty. The results could be fatal.

Use reduced voltage equipment (**110 volt**) for inspection and working lights where possible.

Ensure that the cables of mobile electrical equipment cannot get trapped and damaged, such as in a vehicle hoist. Use air operated mobile equipment where possible in preference to electrical equipment.

In cases of electrocution:-

- switch off electricity before approaching victim
- if this is not possible, push or drag victim from source of electricity using dry non-conductive material
- commence resuscitation if trained to do so
- SUMMON MEDICAL ASSISTANCE

EXHAUST FUMES

These contain asphyxiating, harmful and toxic chemicals and particles such as carbon oxides, nitrogen oxides, aldehydes, lead and aromatic hydrocarbons. Engines should only be run under conditions of adequate extraction or general ventilation and not in confined spaces.

Gasolene (Petrol) Engine

There may not be adequate warning properties of odour or irritation before immediate and delayed toxic or harmful effects arise.

Diesel Engine

Soot, discomfort and irritation usually give adequate warning of hazardous fume concentrations.

FIBRE INSULATION

see Dusts.

Used in noise and sound insulation.

The fibrous nature of surfaces and cut edges can cause skin irritation. This is usually a physical and not a chemical effect.

Precautions should be taken to avoid excessive skin contact through careful organisation of work practices and the use of gloves.

FIRE

see Welding, Foams, Legal Aspects.

Many of the materials found on or associated with the repair of vehicles are highly flammable. Some give off toxic or harmful fumes if burnt.

Observe strict fire safety when storing and handling flammable materials or solvents, particularly near electrical equipment or welding processes.

Ensure before using electrical or welding equipment that there is no fire hazard present.

Have a suitable fire extinguisher available when using welding or heating equipment.

FIRST AID

Apart from meeting any legal requirements it is desirable for someone in the workshop to be trained in first aid procedures.

Splashes in the eye should be flushed with clean water for at least ten minutes.

Soiled skin should be washed with soap and water.

Inhalation affected individuals should be removed to fresh air immediately.

If swallowed or if effects persist consult a doctor with information (label) on material used.

Do not induce vomiting (unless indicated by manufacturer).

FOAMS - Polyurethane

see Fire.

Used in sound and noise insulation. Cured foams used in seat and trim cushioning.

Follow manufacturers instructions.

Unreacted components are irritating and may be harmful to the skin and eyes. Wear gloves and goggles.

Individuals with chronic respiratory diseases, asthma, bronchial medical problems or histories of allergic diseases should not work with or near uncured materials.

The components, vapours, spray mists can cause direct irritation, sensitivity reactions and may be toxic or harmful. Vapours and spray mists must not be breathed. These materials must be applied with adequate ventilation and respiratory protection. Do not remove respirator immediately after spraying, wait until vapour/ mists have cleared.

Burning of the uncured components and the cured foams can generate toxic and harmful fumes.

Smoking, open flames or the use of electrical equipment during foaming operations and until vapours/mists have cleared should not be allowed.

Any heat cutting of cured foams or partially cured foams should be conducted with extraction ventilation (see Body Section 44 Legal and Safety Aspects).

FUELS

see Fire, Legal Aspects, Chemicals - General, Solvents.

Used as fuels and cleaning agents.

Gasolene (Petrol).

Highly flammable.

Swallowing can result in mouth and throat irritation and absorption from the stomach can result in drowsiness and unconsciousness. Small amounts can be fatal to children. Aspiration of liquid into the lungs, e.g. through vomiting, is a very serious hazard.

Gasolene dries the skin and can cause irritation and dermatitis on prolonged or repeated contact. Liquid in the eye causes severe smarting.

Motor gasolene may contain appreciable quantities of benzene, which is toxic upon inhalation and the concentrations of gasolene vapours must be kept very low. High concentrations will cause eye, nose and throat irritation, nausea, headache, depression and symptoms of drunkenness. Very high concentrations will result in rapid loss of consciousness.

Ensure there is adequate ventilation when handling and using gasolene. Great care must be taken to avoid the serious consequences of inhalation in the event of vapour build up arising from spillages in confined spaces.

Special precautions apply to cleaning and maintenance operations on gasolene storage tanks.

Gasolene should not be used as a cleaning agent. It must not be siphoned by mouth.

Kerosene (Paraffin)

Used also as heating fuel, solvent and cleaning agent.

Flammable.

Irritation of the mouth and throat may result from swallowing. The main hazard from swallowing arises if liquid aspiration into the lungs occurs. Liquid contact dries the skin and can cause irritation or dermatitis. Splashes in the eye may be slightly irritating.

In normal circumstances the low volatility does not give rise to harmful vapours. Exposure to mists and vapours from kerosene at elevated temperatures should be avoided (mists may arise in de-waxing).

Avoid skin and eye contact and ensure there is adequate ventilation.

Gas-Oil (Diesel Fuel)

see Fuels (Kerosene).

Combustible.

Gross or prolonged skin contact with high boiling gas oils may also cause serious skin disorders including skin cancer.

GAS CYLINDERS

see Fire.

Gases such as oxygen, acetylene, carbon dioxide, argon and propane are normally stored in cylinders at pressures of up to **140 bar (2000 lb/in²)** and great care should be taken in handling these cylinders to avoid mechanical damage to them or to the valve gear attached. The contents of each cylinder should be clearly identified by appropriate markings.

Cylinders should be stored in well ventilated enclosures, and protected from ice and snow, or direct sunlight. Fuel gases (e.g. acetylene and propane) should not be stored in close proximity to oxygen cylinders.

Care should be exercised to prevent leaks from gas cylinders and lines, and to avoid sources of ignition.

Only trained personnel should undertake work involving gas cylinders.

Gases

see Gas Cylinders.

Gas Shielded Welding

see Welding.

Gas Welding

see Welding.

GENERAL WORKSHOP TOOLS AND EQUIPMENT

It is essential that all tools and equipment are maintained in good condition and the correct safety equipment used where required.

Never use tools or equipment for any purpose other than that for which they were designed.

Never overload equipment such as hoists, jacks, axle and chassis stands or lifting slings. Damage caused by overloading is not always immediately apparent and may result in a fatal failure the next time that the equipment is used.

Do not use damaged or defective tools or equipment, particularly high speed equipment such as grinding wheels. A damaged grinding wheel can disintegrate without warning and cause serious injury.

Wear suitable eye protection when using grinding, chiselling or sand blasting equipment.

Wear a suitable breathing mask when using sand blasting equipment, working with asbestos based materials or using spraying equipment.

Glues

see Adhesives and Sealers.

High Pressure Air, Lubrication and Oil Test Equipment accordance with local regulations

see Lubricants and Greases.

Always keep high pressure equipment in good condition and regularly maintained, particularly at joints and unions.

Never direct a high pressure nozzle at the skin as the fluid may penetrate to the underlying tissue etc. and cause serious injury.

LEGAL ASPECTS

Many laws and regulations make requirements relating to health and safety in the use of materials and equipment in workshops. Always conform to the laws and regulations applicable to the country in which you are working.

Workshops should be familiar, in detail, with the associated laws and regulations. Consult the local factory inspectorate or appropriate authority if in any doubt.

LUBRICANTS AND GREASES

Avoid all prolonged and repeated contact with mineral oils, especially used oils. Used oils contaminated during service (e.g. routine service change sump oils) are more irritating and more likely to cause serious effects including skin cancer in the event of gross and prolonged skin contact.

Wash skin thoroughly after work involving oil. Proprietary hand cleaners may be of value provided they can be removed from the skin with water. Do not use petrol, paraffin or other solvents to remove oil from the skin.

Lubricants and greases may be slightly irritating to the eyes.

Repeated or prolonged skin contact should be avoided by wearing protective clothing if necessary. Particular care should be taken with used oils and greases containing lead. Do not allow work clothing to be contaminated with oil.

Dry clean or launder such clothing at regular intervals. Discard oil soaked shoes.

Do not employ used engine oils as lubricants or for any application where appreciable skin contact is likely to occur. Used oils may only be disposed of in accordance with local regulations.

Noise Insulation Materials

see Foams, Fibre Insulation.

PAINTS

see Solvents and Chemical Materials - General.

Highly Flammable, Flammable.

One Pack. Can contain harmful or toxic pigments, driers and other components as well as solvents. Spraying should only be carried out with adequate ventilation.

Two Pack. Can also contain harmful and toxic unreacted resins and resin hardening agents. The manufacturers instructions should be followed and the section of page 5 on resin based adhesives, isocyanate containing Adhesives and Foams should be consulted.

Spraying should preferably be carried out in exhausted ventilated booths removing vapour and spray mists from the breathing zone. Individuals working in booths should wear respiratory protection. Those doing small scale repair work in the open shop should wear supplied air respirators.

Paint Thinners

see Solvents.

Petrol

see Fuels (Gasolene).

Pressurised Equipment

see High Pressure Air, Lubrication and Oil Test Equipment.

Resistance Welding

see Welding.

Sealers

see Adhesives and Sealers.

SOLDER

see Welding.

Solders are mixtures of metals such that the melting point of the mixture is below that of the constituent metals (normally lead and tin). Solder application does not normally give rise to toxic lead fumes, provided a gas/air flame is used. Oxy-acetylene flames should not be used, as they are much hotter and will cause lead fumes to be evolved. Some fumes may be produced by the application of any flame to surfaces coated with grease etc. and inhalation of these should be avoided.

Removal of excess solder should be undertaken with care, to ensure that fine lead dust is not produced, which can give toxic effects if inhaled. Respiratory protection may be necessary.

Solder spillage and filing should be collected and removed promptly to prevent general air contamination by lead.

High standards of personal hygiene are necessary in order to avoid indigestion of lead or inhalation of solder dust from clothing.

SOLVENTS

see Chemical Materials - General Fuels (Kerosene), Fire.

e.g. Acetone, white spirit, toluene, xylene, trichlorethane.

Used in cleaning materials, de-waxing, paints, plastics, resins, thinners etc.

Highly Inflammable, Flammable.

Skin contact will degrease the skin and may result in irritation and dermatitis following repeated or prolonged contact.

Some can be absorbed through the skin in toxic or harmful quantities.

Splashes in the eye may cause severe irritation and could lead to loss of vision.

Brief exposure to high concentrations of vapours or mists will cause eye and throat irritation, drowsiness, dizziness, headaches and in the worst circumstances, unconsciousness.

Repeated or prolonged exposures to excessive but lower concentrations of vapours or mists, for which there might not be adequate warning indications, can cause more serious toxic or harmful effects.

Aspiration into the lungs (e.g. through vomiting) is the most serious consequence of swallowing.

Avoid splashes to the skin, eyes and clothing. Wear protective gloves, goggles and clothing if necessary. Ensure good ventilation when in use, avoid breathing fumes, vapours and spray mists and keep containers tightly sealed. Do not use in confined spaces. When the spraying material contains solvents, e.g. paints, adhesives, coatings, use extraction ventilation or personal respiratory protection in the absence of adequate general ventilation. Do not apply heat or flame except under specific and detailed manufacturers instructions.

Sound Insulation

see Fibre Insulation, Foams.

Spot Welding

see Welding.

SUSPENDED LOADS

There is always a danger when loads are lifted or suspended. Never work under an unsupported suspended or raised load, e.g. jacked up vehicle, suspended engine, etc. Always ensure that lifting equipment such as jacks, hoists, axle stands, slings, etc. are adequate and suitable for the job, in good condition and regularly maintained. Never improvise lifting tackle.

Underseal

see Corrosion Protection.

WELDING

see Fire, Electric Shock, Gas Cylinders. Welding processes include Resistance Welding (Spot Welding), Arc Welding and Gas Welding.

Resistance Welding

This process may cause particles of molten metal to be emitted at high velocity and the eyes and skin must be protected.

Arc Welding

This process emits a high level of ultraviolet radiation which may cause eye and skin burns to the welder and to other persons nearby. Gas-shielded welding processes are particularly hazardous in this respect. Personal protection must be worn, and screens used to shield other people.

Metal spatter will also occur and appropriate eye and skin protection is necessary.

The heat of the welding arc will produce fumes and gases from the metals being welded and from any applied coatings or contamination on the surfaces being worked on. These gases and fumes may be toxic and inhalation should always be avoided. The use of extraction ventilation to remove the fumes from the working area may be necessary, particularly in cases where the general ventilation is poor, or where considerable welding work is anticipated. In extreme cases where adequate ventilation cannot be provided, supplied air respirators may be necessary.

Gas Welding

Oxy-acetylene torches may be used for welding and cutting and special care must be taken to prevent leakage of these gases, with consequent risk of fire and explosion.

The process will produce metal spatter and eye and skin protection is necessary.

The flame is bright and eye protection should be used, but the ultra-violet emission is much less than that from arc welding, and lighter filters may be used.

The process itself produces few toxic fumes, but such fumes and gases may be produced from coatings on the work, particularly during cutting away of damaged body parts and inhalation of the fumes should be avoided.

In brazing, toxic fumes may be evolved from the metals in the brazing rod, and a severe hazard may arise if brazing rods containing cadmium are used. In this event particular care must be taken to avoid inhalation of fumes and expert advice may be required.

SPECIAL PRECAUTIONS MUST BE TAKEN BEFORE ANY WELDING OR CUTTING TAKES PLACE ON VESSELS WHICH HAVE CONTAINED COMBUSTIBLE MATERIALS, E.G. BOILING OR STEAMING OUT OF FUEL TANKS.

White Spirit

see Solvents.

ECOLOGY AND THE ENVIRONMENT

Soil, air and water are vital factors of agriculture and life in general. Where legislation does not yet rule the treatment of some of the substances which are required by advanced technology, common sense should govern the use and disposal of products of a chemical and petrochemical nature.

The following are recommendations which may be of assistance:

- Become acquainted with and ensure that you understand the relative legislation applicable to your country.
- Where no legislation exists, obtain information from suppliers of oils, filters, batteries, fuels, anti freeze, cleaning agents, etc., with regard to their effect on man and nature and how to safely store, use and dispose of these substances. Agricultural consultants will, in many cases, be able to help you as well.

HELPFUL HINTS

1. Avoid filling tanks using unsuitable containers or inappropriate pressurised fuel delivery systems which may cause considerable spillage.
2. In general, avoid skin contact with all fuels, oils, acids, solvents, etc. Most of them contain substances which can be harmful to your health.
3. Modern oils contain additives. Do not burn contaminated fuels and/or waste oils in ordinary heating systems.
4. Avoid spillage when draining off used engine coolant mixtures, engine, gearbox and hydraulic oils, brake fluids, etc. Do not mix drained brake fluids or fuels with lubricants. Store them safely until they can be disposed of in a proper way to comply with local legislation and available resources.
5. Modern coolant mixtures, i.e. antifreeze and other additives, should be replaced every two years. They should not be allowed to get into the soil but should be collected and disposed of safely.
6. Do not open the air-conditioning system yourself. It contains gases which should not be released into the atmosphere. Your dealer or air conditioning specialist has a special extractor for this purpose and will have to recharge the system anyway.
7. Repair any leaks or defects in the engine cooling or hydraulic system immediately.
8. Do not increase the pressure in a pressurised circuit as this may lead to the components exploding.
9. Protect hoses during welding as penetrating weld splatter may burn a hole or weaken them, causing the loss of oils, coolant, etc.



SERVICE MANUAL
DISTRIBUTION SYSTEMS



**PUMA 165 Multicontroller , PUMA 165 , PUMA 180 Multicontroller , PUMA 180 ,
PUMA 195 Multicontroller , PUMA 195 , PUMA 210 Multicontroller , PUMA 210**

Contents

DISTRIBUTION SYSTEMS - A

PRIMARY HYDRAULIC POWER SYSTEM	A.10.A
PUMA 165 Multicontroller , PUMA 165 , PUMA 180 Multicontroller , PUMA 180 , PUMA 195 Multicontroller , PUMA 195 , PUMA 210 Multicontroller , PUMA 210	
PRIMARY HYDRAULIC POWER SYSTEM Closed center mechanical remote valve	A.10.B
PUMA 165 , PUMA 180 , PUMA 195 , PUMA 210	
PRIMARY HYDRAULIC POWER SYSTEM Electro-hydraulic remote valve	A.10.C
PUMA 165 Multicontroller , PUMA 165 [Z7BH01001 - Z9BH40000] , PUMA 165 [Z7BH50001 - Z9BH60000] , PUMA 180 Multicontroller , PUMA 180 [Z7BH01001 - Z9BH40000] , PUMA 180 [Z7BH50001 - Z9BH60000] , PUMA 195 Multicontroller , PUMA 195 [Z7BH01001 - Z9BH40000] , PUMA 195 [Z7BH50001 - Z9BH60000] , PUMA 210 Multicontroller , PUMA 210 [Z7BH01001 - Z9BH40000] , PUMA 210 [Z7BH50001 - Z9BH60000]	
PRIMARY HYDRAULIC POWER SYSTEM Electro-hydraulic remote valve	A.10.C
PUMA 165 [Z9BH40001 -] , PUMA 165 [Z9BH60001 -] , PUMA 180 [Z9BH40001 -] , PUMA 180 [Z9BH60001 -] , PUMA 195 [Z9BH40001 -] , PUMA 195 [Z9BH60001 -] , PUMA 210 [Z9BH40001 -] , PUMA 210 [Z9BH60001 -]	
SECONDARY HYDRAULIC POWER SYSTEM	A.12.A
PUMA 165 Multicontroller , PUMA 165 , PUMA 180 Multicontroller , PUMA 180 , PUMA 195 Multicontroller , PUMA 195 , PUMA 210 Multicontroller , PUMA 210	
HYDRAULIC COMMAND SYSTEM	A.14.A
PUMA 165 Multicontroller , PUMA 165 , PUMA 180 Multicontroller , PUMA 180 , PUMA 195 Multicontroller , PUMA 195 , PUMA 210 Multicontroller , PUMA 210	
PNEUMATIC SYSTEM	A.20.A
PUMA 165 Multicontroller , PUMA 165 , PUMA 180 Multicontroller , PUMA 180 , PUMA 195 Multicontroller , PUMA 195 , PUMA 210 Multicontroller , PUMA 210	
ELECTRICAL POWER SYSTEM	A.30.A
PUMA 165 Multicontroller , PUMA 165 [Z7BH01001 - Z9BH40000] , PUMA 165 [Z7BH50001 - Z9BH60000] , PUMA 180 Multicontroller , PUMA 180 [Z7BH01001 - Z9BH40000] , PUMA 180 [Z7BH50001 - Z9BH60000] , PUMA 195 Multicontroller , PUMA 195 [Z7BH01001 - Z9BH40000] , PUMA 195 [Z7BH50001 - Z9BH60000] , PUMA 210 Multicontroller , PUMA 210 [Z7BH01001 - Z9BH40000] , PUMA 210 [Z7BH50001 - Z9BH60000]	
ELECTRICAL POWER SYSTEM	A.30.A
PUMA 165 [Z9BH40001 -] , PUMA 165 [Z9BH60001 -] , PUMA 180 [Z9BH40001 -] , PUMA 180 [Z9BH60001 -] , PUMA 195 [Z9BH40001 -] , PUMA 195 [Z9BH60001 -] , PUMA 210 [Z9BH40001 -] , PUMA 210 [Z9BH60001 -]	
ELECTRONIC SYSTEM	A.50.A
PUMA 165 Multicontroller , PUMA 165 , PUMA 180 Multicontroller , PUMA 180 , PUMA 195 Multicontroller , PUMA 195 , PUMA 210 Multicontroller , PUMA 210	
FAULT CODES	A.50.A
PUMA 165 Multicontroller , PUMA 165 , PUMA 180 Multicontroller , PUMA 180 , PUMA 195 Multicontroller , PUMA 195 , PUMA 210 Multicontroller , PUMA 210	



DISTRIBUTION SYSTEMS - A

PRIMARY HYDRAULIC POWER SYSTEM - 10.A

**PUMA 165 Multicontroller , PUMA 165 , PUMA 180 Multicontroller , PUMA 180 ,
PUMA 195 Multicontroller , PUMA 195 , PUMA 210 Multicontroller , PUMA 210**

Contents

DISTRIBUTION SYSTEMS - A

PRIMARY HYDRAULIC POWER SYSTEM - 10.A

TECHNICAL DATA

PRIMARY HYDRAULIC POWER SYSTEM

Special tools	4
Power beyond	
Torque	5
Hydraulic pump	
Variable displacement pump - General specification	6
Variable displacement pump - Torque	6
Charge pump	
General specification	8

FUNCTIONAL DATA

PRIMARY HYDRAULIC POWER SYSTEM

Static description	9
Static description	26
Hydraulic schema	28
Power beyond	
Static description	33
Hydraulic pump	
Static description	34
Overview	38
Charge pump	
Exploded view	40
Compensator	
Exploded view	41

SERVICE

Signal valve	
Pressure test	42
Power beyond	
Remove	44
Install	45
Assemble	46
Hydraulic pump	
Pressure test	47
Variable displacement pump - Remove	50
Variable displacement pump - Overhaul	55

Variable displacement pump - Assemble	59
Variable displacement pump - Install	63
Charge pump	
Overhaul	67
Compensator	
Overhaul	69
Filter	
Replace	71
DIAGNOSTIC	
PRIMARY HYDRAULIC POWER SYSTEM	
Troubleshooting	72

<https://caseihservicemanual.com>

PRIMARY HYDRAULIC POWER SYSTEM - Special tools

DESCRIPTION	PART NUMBER
Tee adaptor 11/16 ORFS female x 11/16 ORFS male x 7/16 UNF female	380000570*
Tee adaptor 7/16 JIC female x 7/16 JIC male x 7/16 UNF female	380000571*
Adaptor M10 banjo x 7/16 UNF female	380000572*
Tee adaptor 9/16 ORFS female x 9/16 ORFS male x 7/16 UNF female	380000572*
Blanking Cap 9/16 ORFS	380000573*
Blanking Cap 7/16 ORFS	380000575*
Adaptor 7/16 UNF female x 1/2 BSP male	380000576*
Adaptor 7/16 UNF female x M12 x 1.5p male	380000577*
Adaptor 7/16 UNF female x M14 x 1.5p male	380000578*
Adaptor M14 banjo x M14 x 1.5p female	380000579*
Tee adaptor 7/16 UNF female x 1/4 BSP hose tail x 1/2 hose	380000580*
7/16 UNF male Quick release adaptor	380000492*
Adaptor M10 x 1.0p x 7/16 UNF female	380000493*
Tee adaptor 1" ORFS female x 1" ORFS male x 7/16 UNF female	380000517
Blanking Cap 11/16 ORFS	380000599*
Pressure Gauge 0–10 bar	380000551#
Pressure Gauge 0–40 bar (5 off)	380000552#
Pressure Gauge 0–250 bar	380000553#
Remote valve coupling	5101741 or 380000554#
Quick release adaptor	380000543
Pressure gauge hose	380000545#
1/8 NPT fitting to attach hose 292246 to gauge	380000544#
Adaptor M10 x 1.0p x 7/16 JIC male (enables use of gauges with 7/16 JIC hoses if used)	380000494
diagnostic switch	380000488
Bypass connector	380000561
Trailer brake fitting	380000550#
Flow Meter 120 ltr/min minimum (procure locally)	
* Part of hydraulic adaptor kit	380000464
# Part of hydraulic pressure test kit	380000240
Remote Valve check valve removal tool	380002720

Power beyond - Torque

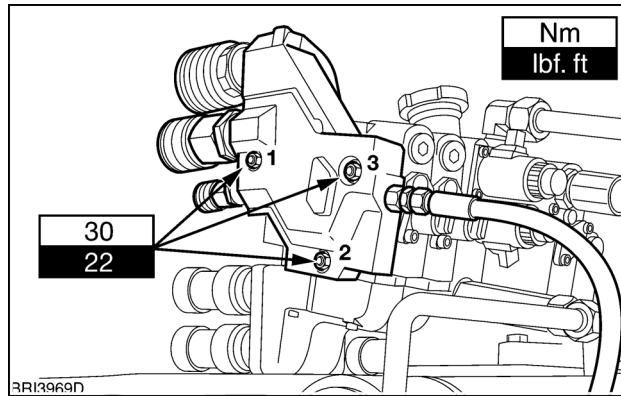

BAIL06CCM056ASA 1

Power Beyond Torque Sequence

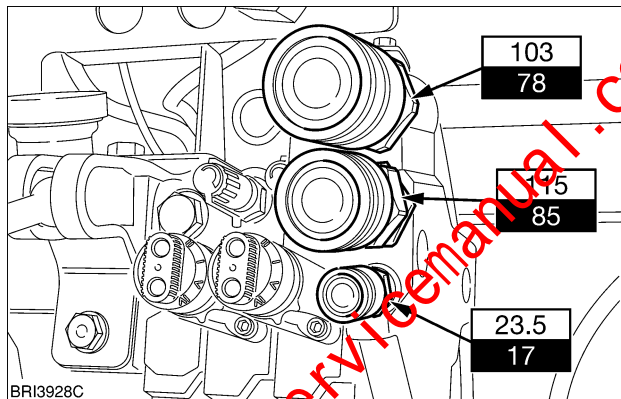

BAIL06CCM180ASA 2

Power Beyond Coupler Torques

Refer to : Power beyond - Install (A.10.A)

Hydraulic pump Variable displacement pump - General specification

Load Sensed Variable Displacement Piston Pump (**120/150 Ltr/Min**)

Type

Rotation

Pump Speed@ **2200 erpm**

Output @ 2200 erpm

Standard Flow

Output @ 2200 erpm

Hi- Flow

Standby Pressure (Low Pressure Standby)

Maximum System Pressure (High Pressure Standby)

Charge Pressure Filter Relief Valve

Charge System Pressure

Variable Flow Piston Pump
(Swash Plate Controlled)

Clockwise

2662 rpm

120 Ltr/min

26.4 Imp Galls/min

31.7 US Galls/min

150 Ltr/min

32.9 Imp Galls/min

39.6 US Galls/min

26±1 bar (377±15 lbf/in2)

210±5 bar (3046±73 lbf/in2)

6 bar

3 bar

<https://caseihservicemanual.com>

Hydraulic pump Variable displacement pump - Torque

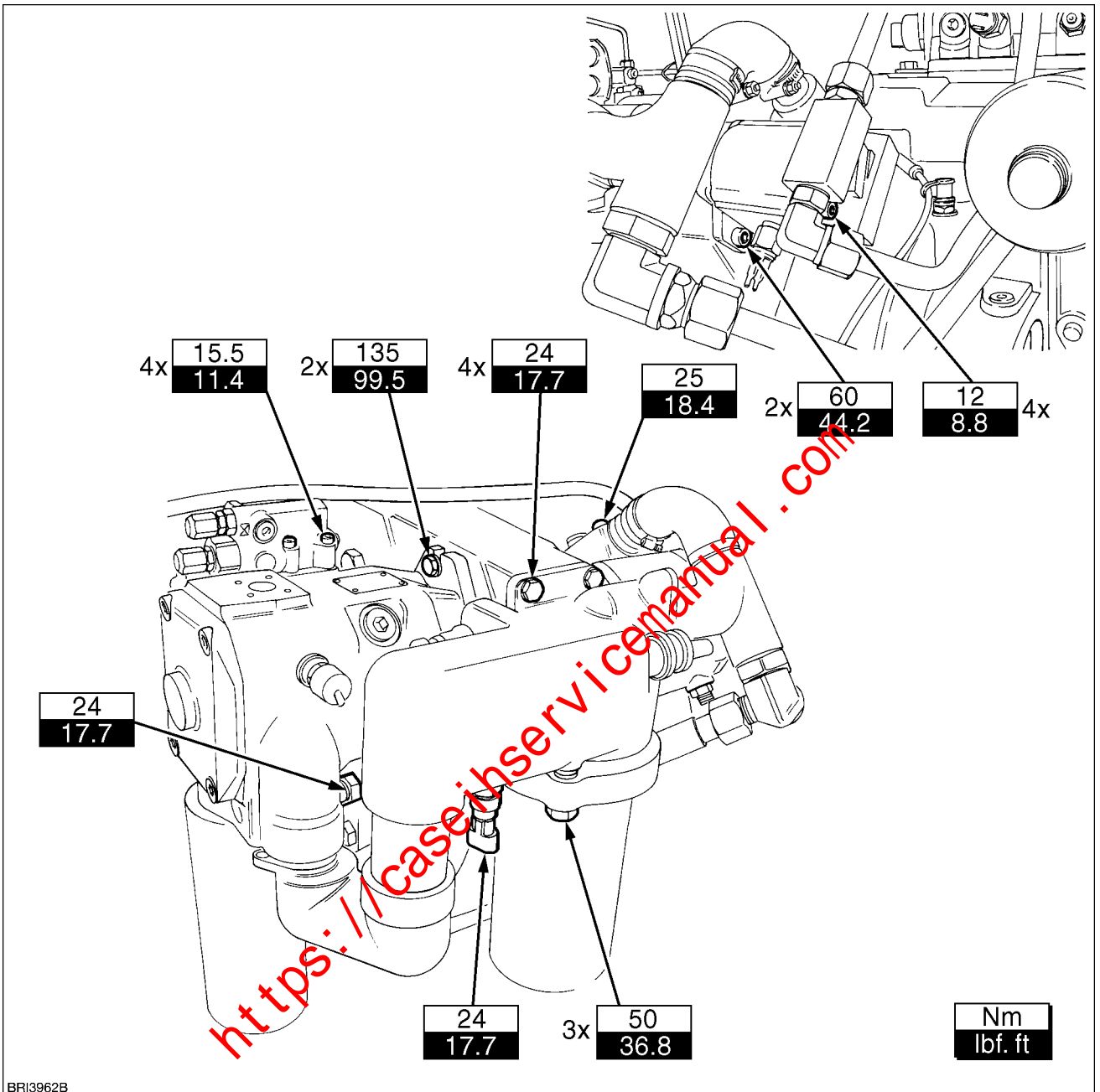

BRI3962B

BAIL06CCM041GSA 1

Charge pump - General specification

Charge Pump (**106 Ltr/Min**)

Type

Charge Pressure Filter Dump Valve

Charge Pressure

Charge Pressure Switch

Gear Type Pump

Crack open @ **6.9 bar (100 lbf/in²)**

Fully Open @ **12.4 bar (180 lbf/in²)**

Minimum **1.6 - 3.4 bar (23 - 50**

lbf/in²)

@ **2100 rev/min** and variable flow
piston pump 'On Load'

Close @ **0.55 - 0.82 bar (8 - 12**

lbf/in²)

Making charge pressure warning light
flash

<https://caseihservicemanual.com>

PRIMARY HYDRAULIC POWER SYSTEM - Static description

The hydraulic system comprises the following oil circuits:-

High pressure circuit

Hydraulic rear powerlift
 Remote valves
 Trailer brake system (where fitted)
 Front axle suspension (where fitted)

Oil circuit of the steering hydraulics

Steering pump and steering cylinder
 Control valve of the Turn Assist (where fitted)

Low pressure circuit

Engine PTO
 Differential lock
 All wheel drive
 Actuation of transmission couplings and synchroniser units
 Front axle servobrake
 Engagement of the crawler gear
 Servo-actuated main brake cylinder
 Front PTO (where fitted)

Layout of the lubrication system

PTO coupling
 Transmission coupling
 Transmission shaft pressure lubrication
 Bearing of the pump drive pinion
 Lifting shaft of the hydraulic powerlift

The high pressure circuit is a closed Load Sensing system and is configured differently according to the variants in equipment for each tractor model.

Steering circuit, low pressure and lubrication circuits are configured as an open system.

VARIATIONS IN EQUIPMENT IN THE TRACTOR HYDRAULICS				
Transmission	High pressure hydraulic system	Hydraulic pump	Hydraulic powerlift	Remote valves
Full powershift transmission	Closed system	120 L/min CCLS variable displacement pump 150 L/min "Hi Flow" axial piston variable displacement pump	Electronic powerlift control	Closed system

CCLS axial piston variable displacement pump (1).
Figure 1 2

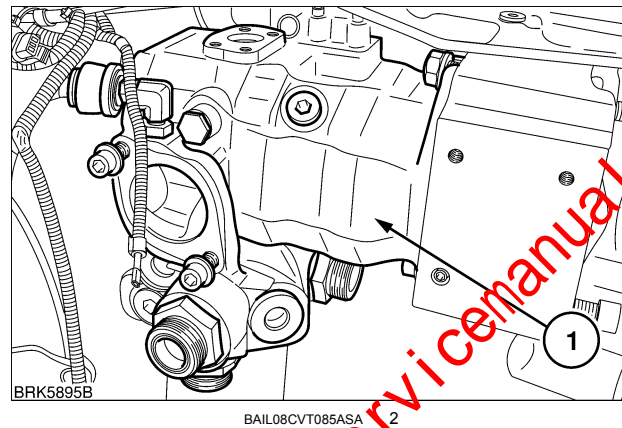
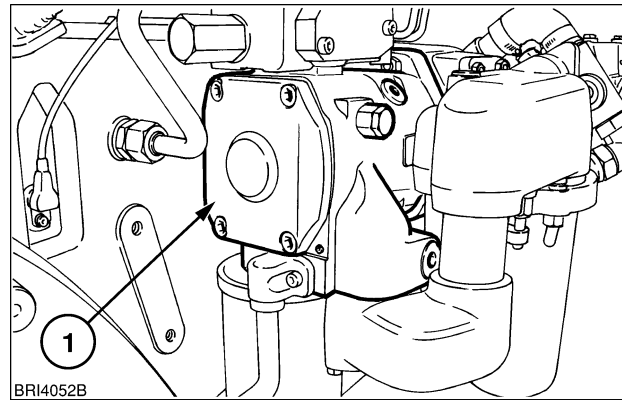

The high-pressure hydraulic pumps in the Load Sensing version with closed circuit can be differentiated by the serial numbers on the plate above the pump:-

Figure 3 shows the rating plate of the **150 l/min (39.6 US gpm)** pump.



Figure 4 shows the rating plate of the **120 l/min (31.7 US gpm)** pump.