

<https://caseih.servicemanual.com>

FARMALL® I10U
FARMALL® I20U
Tier 4B (final)
Tractor

SERVICE MANUAL

Part number 51487919

1st edition English

July 2018





SERVICE MANUAL

Farmall® 110U With 16x16 Semi-Powershift transmission
Farmall® 120U With 16x16 Semi-Powershift transmission

<https://caseihservicemanual.com>

Link Product / Engine

Product	Market Product	Engine
Farmall® 110U With 16x16 Semi-Powershift transmission	North America	F5GFL413V*C001
Farmall® 120U With 16x16 Semi-Powershift transmission	North America	F5GFL413U*C002

<https://caseih.servicemanual.com>

Contents

INTRODUCTION

Engine.....	10
[10.001] Engine and crankcase	10.1
[10.216] Fuel tanks	10.2
[10.206] Fuel filters	10.3
[10.202] Air cleaners and lines	10.4
[10.254] Intake and exhaust manifolds and muffler	10.5
[10.500] Selective Catalytic Reduction (SCR) exhaust treatment.....	10.6
[10.501] Exhaust Gas Recirculation (EGR) exhaust treatment.....	10.7
[10.400] Engine cooling system	10.8
[10.414] Fan and drive	10.9
[10.310] Aftercooler.....	10.10
[10.218] Fuel injection system.....	10.11
Clutch	18
[18.100] Clutch mechanical release control	18.1
[18.112] Slip clutch or flywheel damper	18.2
Transmission.....	21
[21.111] Semi-Powershift transmission	21.1
[21.133] Semi-Powershift transmission external controls	21.2
[21.103] Semi-Powershift transmission hydraulic components.....	21.3
[21.152] Semi-Powershift transmission internal components	21.4
[21.160] Creeper	21.5
[21.109] Transmission cooler and lines.....	21.6
Four-Wheel Drive (4WD) system	23
[23.202] Electro-hydraulic control	23.1
[23.314] Drive shaft.....	23.2

Front axle system	25
[25.100] Powered front axle	25.1
[25.102] Front bevel gear set and differential	25.2
[25.108] Final drive hub, steering knuckles, and shafts	25.3
[25.122] Axle suspension control	25.4
Rear axle system	27
[27.100] Powered rear axle	27.1
[27.106] Rear bevel gear set and differential	27.2
[27.120] Planetary and final drives	27.3
Power Take-Off (PTO)	31
[31.104] Rear electro-hydraulic control	31.1
[31.114] Two-speed rear Power Take-Off (PTO)	31.2
[31.116] Three-speed rear Power Take-Off (PTO)	31.3
[31.142] Front Power Take-Off (PTO) control	31.4
[31.146] Front Power Take-Off (PTO)	31.5
Brakes and controls	33
[33.202] Hydraulic service brakes	33.1
[33.110] Parking brake or parking lock	33.2
[33.220] Trailer brake hydraulic control	33.3
[33.224] Trailer brake pneumatic control	33.4
Hydraulic systems	35
[35.000] Hydraulic systems	35.1
[35.304] Combination pump units	35.2
[35.322] Regulated/Low pressure system	35.3
[35.204] Remote control valves	35.4
[35.100] Main lift system	35.5
[35.114] Three-point hitch control valve	35.6
[35.116] Three-point hitch cylinder	35.7

[35.160] Front hitch controls and lines	35.8
[35.162] Front hitch cylinders and lines	35.9
[35.300] Reservoir, cooler, and filters.....	35.10
[35.350] Safety and main relief valves	35.11
Hitches, drawbars, and implement couplings.....	37
[37.100] Drawbars and towing hitches	37.1
[37.110] Rear three-point hitch	37.2
[37.120] Rear three-point hitch linkage.....	37.3
[37.162] Front hitch.....	37.4
[37.166] Front hitch linkage.....	37.5
Frames and ballasting	39
[39.140] Ballasts and supports	39.1
Steering.....	41
[41.101] Steering control	41.1
[41.106] Tie rods.....	41.2
[41.200] Hydraulic control components.....	41.3
[41.216] Cylinders	41.4
Wheels	44
[44.511] Front wheels.....	44.1
[44.520] Rear wheels.....	44.2
Cab climate control	50
[50.100] Heating.....	50.1
[50.104] Ventilation	50.2
[50.200] Air conditioning.....	50.3
Electrical systems	55
[55.100] Harnesses and connectors.....	55.1
[55.525] Cab engine controls.....	55.2

[55.015] Engine control system.....	55.3
[55.201] Engine starting system.....	55.4
[55.301] Alternator.....	55.5
[55.302] Battery.....	55.6
[55.202] Cold start aid.....	55.7
[55.011] Fuel tank system.....	55.8
[55.010] Fuel injection system.....	55.9
[55.014] Engine intake and exhaust system.....	55.10
[55.988] Selective Catalytic Reduction (SCR) electrical system.....	55.11
[55.989] Exhaust Gas Recirculation (EGR) electrical system.....	55.12
[55.012] Engine cooling system.....	55.13
[55.013] Engine oil system.....	55.14
[55.640] Electronic modules.....	55.15
[55.513] Cab transmission controls.....	55.16
[55.024] Transmission control system.....	55.17
[55.020] Transmission speed sensors.....	55.18
[55.021] Transmission pressure sensors and switches.....	55.19
[55.022] Transmission temperature sensors.....	55.20
[55.040] Four-Wheel Drive (4WD) control system.....	55.21
[55.045] Front axle control system.....	55.22
[55.046] Rear axle control system.....	55.23
[55.522] Cab Power Take-Off (PTO) controls.....	55.24
[55.048] Rear Power Take-Off (PTO) control system.....	55.25
[55.049] Front Power Take-Off (PTO) control system.....	55.26
[55.519] Cab brake controls.....	55.27
[55.031] Parking brake electrical system.....	55.28
[55.032] Trailer brake electrical system.....	55.29
[55.512] Cab controls.....	55.30
[55.035] Remote control valve electric control.....	55.31

[55.051] Cab Heating, Ventilation, and Air-Conditioning (HVAC) controls.....	55.32
[55.050] Heating, Ventilation, and Air-Conditioning (HVAC) control system.....	55.33
[55.523] Cab hitch controls	55.34
[55.130] Rear three-point hitch electronic control system	55.35
[55.785] Precision farming system	55.36
[55.911] Satellite navigation systems.....	55.37
[55.680] Autopilot/Autoguidance	55.38
[55.518] Wiper and washer system.....	55.39
[55.404] External lighting	55.40
[55.405] External lighting switches and relays	55.41
[55.408] Warning indicators, alarms, and instruments	55.42
[55.905] ISOBUS components	55.43
[55.DTC] FAULT CODES.....	55.44
Front loader and bucket.....	82
[82.100] Arm.....	82.1
Accessories	88
[88.100] Accessories	88.1
Platform, cab, bodywork, and decals.....	90
[90.150] Cab.....	90.1
[90.151] Cab interior.....	90.2
[90.160] Cab interior trim and panels.....	90.3
[90.154] Cab doors and hatches	90.4
[90.156] Cab windshield and windows	90.5
[90.118] Protections and footboards.....	90.6
[90.120] Mechanically-adjusted operator seat.....	90.7
[90.124] Pneumatically-adjusted operator seat.....	90.8
[90.100] Engine hood and panels	90.9
[90.102] Engine shields, hood latches, and trims	90.10

<https://caseihservicemanual.com>



INTRODUCTION

<https://caseih.servicemanual.com>

Contents

INTRODUCTION

Foreword - Important notice regarding equipment servicing	3
Note to the Owner WARNINGS FOR AIR CONDITIONING SYSTEM REPAIR OPERATIONS	4
Safety rules	5
Safety rules	6
Safety rules - Ecology and the environment	9
Personal safety CAB AIR CONDITIONING SYSTEM	10
Basic instructions - Shop and assembly	11
Capacities	13
Consumables	14
Hydraulic contamination	15
Product identification - Serial Number (17 Digit PIN)	16

<https://caseihservicemanual.com>

Foreword - Important notice regarding equipment servicing

All repair and maintenance work listed in this manual must be carried out only by qualified dealership personnel, strictly complying with the instructions given, and using, whenever possible, the special tools.

Anyone who performs repair and maintenance operations without complying with the procedures provided herein shall be responsible for any subsequent damages.

The manufacturer and all the organizations of its distribution chain, including - without limitation - national, regional, or local dealers, reject any responsibility for damages caused by parts and/or components not approved by the manufacturer, including those used for the servicing or repair of the product manufactured or marketed by the manufacturer. In any case, no warranty is given or attributed on the product manufactured or marketed by the manufacturer in case of damages caused by parts and/or components not approved by the manufacturer.

The manufacturer reserves the right to make improvements in design and changes in specifications at any time without notice and without incurring any obligation to install them on units previously sold. Specifications, descriptions, and illustrative material herein are as accurate as known at time of publication but are subject to change without notice.

In case of questions, refer to your CASE IH Sales and Service Networks.

<https://caseihservicemanual.com>

Note to the Owner WARNINGS FOR AIR CONDITIONING SYSTEM REPAIR OPERATIONS

Starting the system at low temperatures can damage the compressor. Only operate the air conditioner when the engine is hot and the temperature inside the cab is at least **20 °C (68.00 °F)**.

When disconnecting the hoses, close the ends with plastic caps to prevent foreign matter and humidity from getting inside the hoses.

Handle the thermostatic sensor carefully to avoid damage that may prevent efficient system operation.

Always use two spanners to unscrew the hose fittings to avoid twisting the fitting.

Do not use any type of engine oil to lubricate the compressor and the system.

Never leave the compressor oil container open, always make sure that it is tightly closed. If left exposed the oil will absorb humidity from the air and may, subsequently, damage the system.

Do not transfer compressor oil from the original container to another container.

Do not introduce any additives to the compressor oil. Any additional substances could contain elements which are incompatible with the chemical base of the refrigerant and thus alter its characteristics.

Check that the thermostatic sensor is correctly inserted in the fins on the evaporator to ensure efficient system operation.

<https://caseihservicemanual.com>

Safety rules

Personal safety





This is the safety alert symbol. It is used to alert you to potential personal injury hazards. Obey all safety messages that follow this symbol to avoid possible death or injury.

Throughout this manual you will find the signal words DANGER, WARNING, and CAUTION followed by special instructions. These precautions are intended for the personal safety of you and those working with you.

Read and understand all the safety messages in this manual before you operate or service the machine.

 DANGER indicates a hazardous situation that, if not avoided, will result in death or serious injury.

 WARNING indicates a hazardous situation that, if not avoided, could result in death or serious injury.

 CAUTION indicates a hazardous situation that, if not avoided, could result in minor or moderate injury.

FAILURE TO FOLLOW DANGER, WARNING, AND CAUTION MESSAGES COULD RESULT IN DEATH OR SERIOUS INJURY.

Machine safety

NOTICE: Notice indicates a situation that, if not avoided, could result in machine or property damage.

Throughout this manual you will find the signal word Notice followed by special instructions to prevent machine or property damage. The word Notice is used to address practices not related to personal safety.

Information

NOTE: Note indicates additional information that clarifies steps, procedures, or other information in this manual.

Throughout this manual you will find the word Note followed by additional information about a step, procedure, or other information in the manual. The word Note is not intended to address personal safety or property damage.

Safety rules

ACCIDENT PREVENTION

Most accidents or injuries that occur in workshops are the result of non-observance of simple and fundamental safety regulations.

For this reason, IN MOST CASES THESE ACCIDENTS CAN BE AVOIDED: by foreseeing possible causes and consequently acting with the necessary caution and care.

Accidents may occur with all types of machine, regardless of how well the machine in question was designed and built.

A careful and prudent mechanic is the best insurance against any accident.

Precise observance of the most basic safety rule is normally sufficient to avoid many serious accidents.

DANGER: Never carry out any cleaning, lubrication or maintenance operations when the engine is running.

GENERALITIES

- Carefully follow specified repair and maintenance procedures.
- Do not wear rings, wristwatches, jewellery, unbuttoned or loose articles of clothing such as: ties, torn clothing, scarves, open jackets or shirts with open zips that may remain entangled in moving parts.
It is advised to wear approved safety clothing, e.g: non-slip footwear, gloves, safety goggles, helmets, etc.
- Do not carry out repair operations with someone sitting in the driver's seat, unless the person is a trained technician who is assisting with the operation in question.
- Operate the vehicle and use the implements exclusively from the driver's seat.
- Do not carry out operations on the vehicle with the engine running, unless specifically indicated.
- Stop the engine and ensure that all pressure is relieved from hydraulic circuits before removing caps, covers, valves, etc.
- All repair and maintenance operations must be carried out with the greatest care and attention.
- Service stairs and platforms used in a workshop or in the field should be built in compliance with the safety rules in force.
- Disconnect the batteries and label all controls to indicate that the vehicle is being serviced. Block the machine and all equipment which should be raised.
- Do not check or fill fuel tanks, accumulator batteries, nor use starting liquid when smoking or near naked flames, as these fluids are inflammable.
- Brakes are inoperative if manually released for repair or maintenance purposes.
In such cases, the machine should be kept constantly under control using blocks or similar devices.
- The fuel nozzle should always be in contact with the filling aperture. Maintain this position until filling operations are completed in order to avoid possible sparks caused by the accumulation of static electricity.
- Only use specified towing points for towing the tractor. Connect the parts carefully and make sure that all pins and/or locks are secured in position before applying traction.
Never remain near the towing bars, cables or chains that are operating under load
- To move a disabled machine, use a trailer or a low-boy, if available.
- When loading or unloading the vehicle from the trailer, or other means of transport, select a flat area capable of sustaining the trailer or truck wheels, firmly secure the tractor to the truck or trailer and lock the wheels in the position.
- For electrical heaters, battery-chargers and similar equipment use exclusive auxiliary power supplies with a efficient ground to avoid electrical shock hazard.
- Always use lifting equipment and similar of appropriate capacity to lift or move heavy components.
- Take extra care if bystanders are present.
- Never pour gasoline or diesel oil into open, wide and low containers.
- Never use gasoline, diesel oil or other inflammable liquids as cleaning agents. Use non-flammable non-toxic proprietary solvents.
- Wear safety goggles with side guards when cleaning parts with compressed air.

INTRODUCTION

- Limit the air pressure to a maximum of **2.1 bar (30.5 psi)**, according to local regulations.
- Do not run the engine in confined spaces without suitable ventilation.
- Do not smoke, use naked flames, or cause sparks in the area when fuel filling or handling highly inflammable liquids.
- Never use naked flames for lighting when working on the machine or checking for leaks.
- All movements must be carried out carefully when working under, on or near the vehicle and wear protective equipment: helmets, goggles and special footwear.
- When carrying out checks with the engine running, request the assistance of an operator in the driver's seat. The operator must maintain visual contact with the service technician at all times.
- If operating outside the workshop, position the machine on a flat surface and lock in position. If working on a slope, lock the vehicle in position and move to a flat area as soon as possible in order to ensure a safety position.
- Damaged or bent chains or cables are unreliable. Do not use them for lifting or trailing.
Always use suitable protective gloves when handling chains or cables.
- Chains should always be safely secured. Ensure that the connection is strong enough to hold the expected load. No persons should stop near the fastening point, trailing chains or cables.
- Maintenance and repair operations must be carried out in a CLEAN and DRY area, eliminate any water or oil spillage immediately.
- Do not create piles of oil or grease--soaked rags as they represent a serious fire hazard; store them in a closed metal container.
Before starting the vehicle or implements, make sure that the driver's seat is locked in position and always check that the area is free of persons or obstacles.
- Empty pockets of all objects that may unintentionally fall into the vehicle parts when disassembled.
- In the presence of protruding metal parts, use protective goggles or goggles with side guards, helmets, special footwear and gloves.
- Handle all parts carefully, do not put your hands or fingers between moving parts, wear suitable safety clothing -- safety goggles, gloves and shoes.

WELDING OPERATIONS

- When welding, use protective safety devices: tinted safety goggles, helmets, special overalls, gloves and footwear. All persons present in the area where welding is taking place must wear tinted goggles.
DO NOT LOOK AT ARC WITHOUT PROPER EYE PROTECTION.
- Where possible, remove the part or tool that requires arc welding from the tractor.
- Disconnect both cables from the battery. Isolate the cable ends to avoid contact with each other and the tractor.
- Position the welder ground clamp as near as possible to the area where welding is taking place.
- Remove the electronic control units located on the tractor if welding is to be carried out near these control units.
- Never allow welding cables to lay on, near or across any electrical wiring or electronic component while welding is in progress.
- Metal cables tend to fray with repeated use. Always use suitable protective devices (gloves, goggles, etc.) when handling cables.

START UP

- Never start the engine in confined spaces that are not equipped with adequate ventilation for exhaust gas extraction.
- Never bring your head, body, arms, legs, feet, hands, fingers near fans or rotating belts.

MOTOR

- Always loosen the radiator cap slowly before removing it to allow any remaining pressure in the system to be discharged. Coolant should be topped up only when the engine is stopped or idle if hot.
- Never fill up with fuel when the engine is running, especially if hot, in order to prevent the outbreak of fire as a result of fuel spillage
- Never check or adjust fan belt tension when the engine is running.

Never adjust the fuel injection pump when the vehicle is moving.

- Never lubricate the vehicle when the engine is running.

ELECTRICAL SYSTEMS

- If it is necessary to use auxiliary batteries, the cables must be connected at both sides as follows: (+) with (+) and (-) with (-).
- Avoid short-circuiting the terminals. GAS RELEASED FROM BATTERIES IS HIGHLY INFLAMMABLE.
- During charging, leave the battery compartment uncovered to improve ventilation.
- Do not check charge by placing metal articles across battery terminals.
- Avoid sparks or flames near the battery zone to prevent explosion hazards.
- Before servicing operations, check for fuel or current leaks. Eliminate any eventual leaks before starting work.
- Never charge batteries in confined spaces. Make sure that there is adequate ventilation in order to prevent accidental explosion hazards as a result of the accumulation of gases released during charging operations.
- Always disconnect the battery before performing any kind of servicing on the electrical system.

HYDRAULIC SYSTEMS

- Some fluid slowly coming out from a very small port can be almost invisible and be strong enough to penetrate the skin. Check for leaks using a piece of cardboard, NEVER USE HANDS.
- If any liquid penetrates skin tissue, call for medical aid immediately
- Serious skin infections may result if medical attention is not given.
- Use the specific tools when checking pressure values on the hydraulic system.

WHEELS AND TYRES

- Make certain that tires are correctly inflated to the pressure indicated by the Manufacturer. Periodically check possible damages to the rims and tires.
- Stand away from (at the side of) the tyre when checking inflation pressure.
- Only check pressure when the vehicle is unloaded and the tyres are cold, to avoid incorrect readings as a result of over-pressure.
- Do not re-use parts of recovered wheels as incorrect welding or brazing may heat the material, causing it to weaken and eventually damage or break the wheel.
- Never cut, nor weld a rim with the inflated tire assembled.
- When removing the wheels, lock both the front and rear vehicle wheels.
- Always position support stands when raising the vehicle, in order to conform to current safety regulations.
- Deflate the tyre before removing any object caught into the tyre tread.
- Never inflate tyres using inflammable gases; this could cause an explosion and put operator safety at risk.

REMOVAL AND RE-FITTING

- Lift and handle all heavy parts using suitable lifting equipment and make sure that all slings and hooks are correctly secured.
- Handle all parts carefully during lifting operations, be careful to personnel working near the load to be lifted. Never insert hands or fingers between parts, always wear approved accident prevention clothing (goggles, gloves and work boots).
- Avoid twisting chains or metal cables and always wear safety gloves when handling cables or chains.

Safety rules - Ecology and the environment

Soil, air, and water quality is important for all industries and life in general. When legislation does not yet rule the treatment of some of the substances that advanced technology requires, sound judgment should govern the use and disposal of products of a chemical and petrochemical nature.

Familiarize yourself with the relative legislation applicable to your country, and make sure that you understand this legislation. Where no legislation exists, obtain information from suppliers of oils, filters, batteries, fuels, anti-freeze, cleaning agents, etc., with regard to the effect of these substances on man and nature and how to safely store, use, and dispose of these substances.

Helpful hints

- Avoid the use of cans or other inappropriate pressurized fuel delivery systems to fill tanks. Such delivery systems may cause considerable spillage.
- In general, avoid skin contact with all fuels, oils, acids, solvents, etc. Most of these products contain substances that may be harmful to your health.
- Modern oils contain additives. Do not burn contaminated fuels and or waste oils in ordinary heating systems.
- Avoid spillage when you drain fluids such as used engine coolant mixtures, engine oil, hydraulic fluid, brake fluid, etc. Do not mix drained brake fluids or fuels with lubricants. Store all drained fluids safely until you can dispose of the fluids in a proper way that complies with all local legislation and available resources.
- Do not allow coolant mixtures to get into the soil. Collect and dispose of coolant mixtures properly.
- The air-conditioning system contains gases that should not be released into the atmosphere. Consult an air-conditioning specialist or use a special extractor to recharge the system properly.
- Repair any leaks or defects in the engine cooling system or hydraulic system immediately.
- Do not increase the pressure in a pressurized circuit as this may lead to a component failure.
- Protect hoses during welding. Penetrating weld splatter may burn a hole or weaken hoses, allowing the loss of oils, coolant, etc.

Battery recycling

Batteries and electric accumulators contain several substances that can have a harmful effect on the environment if the batteries are not properly recycled after use. Improper disposal of batteries can contaminate the soil, groundwater, and waterways. CASE IH strongly recommends that you return all used batteries to a CASE IH dealer, who will dispose of the used batteries or recycle the used batteries properly. In some countries, this is a legal requirement.



Mandatory battery recycling

NOTE: The following requirements are mandatory in Brazil.

Batteries are made of lead plates and a sulfuric acid solution. Because batteries contain heavy metals such as lead, CONAMA Resolution 401/2008 requires you to return all used batteries to the battery dealer when you replace any batteries. Do not dispose of batteries in your household garbage.

Points of sale are obliged to:

- Accept the return of your used batteries
- Store the returned batteries in a suitable location
- Send the returned batteries to the battery manufacturer for recycling

Personal safety CAB AIR CONDITIONING SYSTEM

SAFETY REGULATIONS

- The refrigerant must be handled with great care in order to avoid personal injury; always use safety goggles and gloves.
- Liquid refrigerant can cause freezing of the skin and serious damage to the eyes, sometimes resulting in permanent blindness.
- Keep the refrigerant container away from heat sources. Heat will cause an increase in pressure of the refrigerant and could cause the container to explode.
- If refrigerant comes into contact with a naked flame or a hot metal surface it produces a toxic gas, which is dangerous if inhaled.
- In order to avoid accidents follow the simple precautions described below.
- The operation of emptying and charging the system must be carried out in a well-ventilated area, well away from any naked flames.
- During the charging and emptying operations, take the necessary precautions to protect the face and above all the eyes from accidental contact with refrigerant.
- In the event of an accident, proceed as follows:
 - if refrigerant splashes into the eyes, wash immediately with a few drops of mineral oil, then wash them thoroughly with a solution of boric acid and water (one spoonful of acid in 1/4 cup of water) and seek medical assistance immediately.
 - freezing of the skin caused by contact with liquid refrigerant may be treated by gradually warming the injured area with cold water, followed by the application of a greasy cream. Request medical assistance.
 - the air conditioning system contains a mixture of refrigerant and oil under high pressure; under no circumstances loosen pipe fittings/unions or work on the pipes without having first drained the system.
 - do not loosen or remove the compressor oil level check cap with the system pressurized.
 - do not heat the refrigerant container. If the temperature exceeds **50 °C (122.00 °F)** the pressure will increase very rapidly.
 - keep the air conditioning system away from heat sources to prevent explosions as a result of an increase in pressure in the system piping.
- When transferring refrigerant from one container to another, only use homologated liquid refrigerant containers equipped with safety valves.
- Never fill liquid refrigerant containers over **80% (80.0%)** of their maximum capacity.
- Do not modify the settings of safety valves and the control devices.
- Never connect the recovery/recycling and evacuation/charging stations to electrical power outlets with voltages other than those specified; do not leave the stations powered up unless they are to be used immediately.

Basic instructions - Shop and assembly

Shimming

For each adjustment operation, select adjusting shims and measure the adjusting shims individually using a micrometer, then add up the recorded values. Do not rely on measuring the entire shimming set, which may be incorrect, or the rated value shown on each shim.

Rotating shaft seals

For correct rotating shaft seal installation, proceed as follows:

1. Before assembly, allow the seal to soak in the oil it will be sealing for at least thirty minutes.
2. Thoroughly clean the shaft and check that the working surface on the shaft is not damaged.
3. Position the sealing lip facing the fluid.

NOTE: *With hydrodynamic lips, take into consideration the shaft rotation direction and position the grooves so that they will move the fluid towards the inner side of the seal.*

4. Coat the sealing lip with a thin layer of lubricant (use oil rather than grease). Fill the gap between the sealing lip and the dust lip on double lip seals with grease.
5. Insert the seal in its seat and press down using a flat punch or seal installation tool. Do not tap the seal with a hammer or mallet.
6. While you insert the seal, check that the seal is perpendicular to the seat. When the seal settles, make sure that the seal makes contact with the thrust element, if required.
7. To prevent damage to the seal lip on the shaft, position a protective guard during installation operations.

O-ring seals

Lubricate the O-ring seals before you insert them in the seats. This will prevent the O-ring seals from overturning and twisting, which would jeopardize sealing efficiency.

Sealing compounds

Apply a sealing compound on the mating surfaces when specified by the procedure. Before you apply the sealing compound, prepare the surfaces as directed by the product container.

Spare parts

Only use CNH Original Parts or CASE IH Original Parts.

Only genuine spare parts guarantee the same quality, duration, and safety as original parts, as they are the same parts that are assembled during standard production. Only CNH Original Parts or CASE IH Original Parts can offer this guarantee.

When ordering spare parts, always provide the following information:

- Machine model (commercial name) and Product Identification Number (PIN)
- Part number of the ordered part, which can be found in the parts catalog

Protecting the electronic and/or electrical systems during charging and welding

To avoid damage to the electronic and/or electrical systems, always observe the following practices:

1. Never make or break any of the charging circuit connections when the engine is running, including the battery connections.
2. Never short any of the charging components to ground.
3. Always disconnect the ground cable from the battery before arc welding on the machine or on any machine attachment.
 - Position the welder ground clamp as close to the welding area as possible.
 - If you weld in close proximity to a computer module, then you should remove the module from the machine.
 - Never allow welding cables to lie on, near, or across any electrical wiring or electronic component while you weld.
4. Always disconnect the negative cable from the battery when charging the battery in the machine with a battery charger.

NOTICE: *If you must weld on the unit, you must disconnect the battery ground cable from the machine battery. The electronic monitoring system and charging system will be damaged if this is not done.*

5. Remove the battery ground cable. Reconnect the cable when you complete welding.

⚠ WARNING

Battery acid causes burns. Batteries contain sulfuric acid.

Avoid contact with skin, eyes or clothing. Antidote (external): Flush with water. Antidote (eyes): flush with water for 15 minutes and seek medical attention immediately. Antidote (internal): Drink large quantities of water or milk. Do not induce vomiting. Seek medical attention immediately. Failure to comply could result in death or serious injury.

W0111A

Special tools

The special tools that CASE IH suggests and illustrate in this manual have been specifically researched and designed for use with CASE IH machines. The special tools are essential for reliable repair operations. The special tools are accurately built and rigorously tested to offer efficient and long-lasting operation.

By using these tools, repair personnel will benefit from:

- Operating in optimal technical conditions
- Obtaining the best results
- Saving time and effort
- Working in safe conditions

Capacities

	QUANTITY
Engine (cooling)	16.0 L (4.2 US gal)
Windshield washer reservoir	2 L (0.5 US gal)
Fuel tank	165.0 L (43.6 US gal)
tank DEF/AdBlue®	12.0 L (3.2 US gal)
Engine (lubrication)	8.5 L (2 US gal)
Braking system	0.7 L (0.18 US gal)
Front axle	4.5 L (1.2 US gal)
Front axle side reduction gears (each)	1.0 L (0.3 US gal)
Transmission	63.0 L (16.6 US gal)
Hydraulic system	0.4 L (0.1 US gal)
Front Power Take-Off	0.4 L (0.1 US gal)
Various grease nipples	As necessary
Refrigerant of the air-conditioning system	650 g (22.9 oz)
Air-conditioning system lubrication oil	190 cm³ (11.6 in³)

<https://caseih.servicemanual.com>

Consumables

SYSTEMS OR COMPONENTS	RECOMMENDED CASE IH PRODUCTS	SPECIFICATION CASE IH	international specification
Engine (cooling)	CASE IH AKCELA ACTIFULL™ OT EXTENDED LIFE COOLANT (If the premixed coolant is not available, mix the concentrate with 50% distilled water)	MAT3624	ASTM 6210
Engine (lubrication)	CASE IH AKCELA UNITEK NO. 1™ SSL CJ-4 SAE 0W-40 or CASE IH AKCELA UNITEK NO. 1™ SBL CJ-4 SAE 10W-40	MAT3521	API CJ-4
	CASE IH AKCELA NO. 1™ ENGINE OIL CJ-4 SAE 15W-40	MAT3522	API CJ-4
Braking system	CASE IH AKCELA LHM FLUID		ISO 7308
Transmission Hydraulic System Front axle Front axle final drives Front Power Take-Off	CASE IH AKCELA NEXPLORE™ FLUID	MAT3525	API GL4 ISO 32/46 SAE 10W-30
Various grease nipples	CASE IH AKCELA 251H EP MULTI-PURPOSE GREASE	251H EP	NLGI 2
Refrigerant of the air conditioning system	R134A	—	—
Lubrication oil of the air conditioning system	SANDEN SP-10 LUBRICANT	—	PAGE-46

Hydraulic contamination

Contamination in the hydraulic system is a major cause of the malfunction of hydraulic components. Contamination is any foreign material in the hydraulic oil.

Contamination can enter the hydraulic system in several ways:

- When you drain the oil or disconnect any line
- When you disassemble a component
- From normal wear of the hydraulic components
- From damaged seals or worn seals
- From a damaged component in the hydraulic system

All hydraulic systems operate with some contamination. The design of the components in this hydraulic system permits efficient operation with a small amount of contamination. An increase in this amount of contamination can cause problems in the hydraulic system.

The following list includes some of these problems:

- Cylinder rod seals that leak
- Control valve spools that do not return to neutral
- Movement of control valve spools is difficult
- Hydraulic oil that becomes too hot
- Pump gears, housing, and other parts that wear rapidly
- Relief valves or check valves held open by dirt
- Quick failure of components that have been repaired
- Slow cycle times are slow. The machine does not have enough power.

If your machine has any of these problems, check the hydraulic oil for contamination.

There are two types of contamination: microscopic and visible.

Microscopic contamination occurs when very fine particles of foreign material are suspended in the hydraulic oil. These particles are too small to see or feel. Microscopic contamination can be found by identification of the following problems or by testing in a laboratory.

Examples of problems caused by microscopic contamination:

- Cylinder rod seals that leak
- Control valve spools that do not return to neutral
- The hydraulic system has a high operating temperature

Visible contamination is foreign material that can be found by sight, touch, or odor. Visible contamination can cause a sudden failure of components.

Examples of problems caused by visible contamination:

- Particles of metal or dirt in the oil
- Air in the oil
- Dark or thick oil
- Oil with an odor of burned oil
- Water in the oil

If you find contamination, use a portable filter to clean the hydraulic system.

Product identification - Serial Number (17 Digit PIN)

17 DIGIT Product Identification Number (PIN)

The Product Identification Number (PIN), also displayed as Vehicle Identification Number (VIN) on the Identification Plate of the tractor, is made by the following fields:

① HLR	② FU100	③ C	④ F	⑤ LP	⑥ 00001
-----------------	-------------------	---------------	---------------	----------------	-------------------

MOIL17TR02126GA 1

1	DIGIT # 1, 2, 3	PLANT CODE: HLR = Jesi
2	DIGIT # 4, 5, 6, 7, 8	MODEL IDENTIFICATION: FU100 = FARMALL 100U FU110 = FARMALL 110U FU120 = FARMALL 120U
3	DIGIT # 9	CHECK CODE: Alphabetic Letters from A to Z
4	DIGIT # 10	PRODUCTION YEAR:: F=2015 G=2016 H=2017 ect.
5	DIGIT # 11, 12	HOMOLOGATION TYPE: LP = Case IH
6	DIGIT # 13, 14, 15, 16, 17	INCREMENTAL CODE: 00001, 00002, 00003, ect

For further identification information refer to **Product identification** plates of the tractor.



SERVICE MANUAL

Engine

Farmall® 110U With 16x16 Semi-Powershift transmission
Farmall® 120U With 16x16 Semi-Powershift transmission

<https://caseihservicemanual.com>

Contents

Engine - 10

[10.001] Engine and crankcase	10.1
[10.216] Fuel tanks	10.2
[10.206] Fuel filters	10.3
[10.202] Air cleaners and lines	10.4
[10.254] Intake and exhaust manifolds and muffler	10.5
[10.500] Selective Catalytic Reduction (SCR) exhaust treatment	10.6
[10.501] Exhaust Gas Recirculation (EGR) exhaust treatment	10.7
[10.400] Engine cooling system	10.8
[10.414] Fan and drive	10.9
[10.310] Aftercooler	10.10
[10.218] Fuel injection system	10.11

<https://caseihservicemanual.com>



Engine - 10

Engine and crankcase - 001

<https://caseihservicemanual.com>
Farmall® 110U With 16x16 Semi-Powershift transmission
Farmall® 120U With 16x16 Semi-Powershift transmission

Contents

Engine - 10

Engine and crankcase - 001

TECHNICAL DATA

Engine	
Torque	3

SERVICE

Engine	
Remove	4
Install	14
Check - Oil level	24
Replace - Oil and filter	25

<https://caseihservicemanual.com>

Engine - Torque

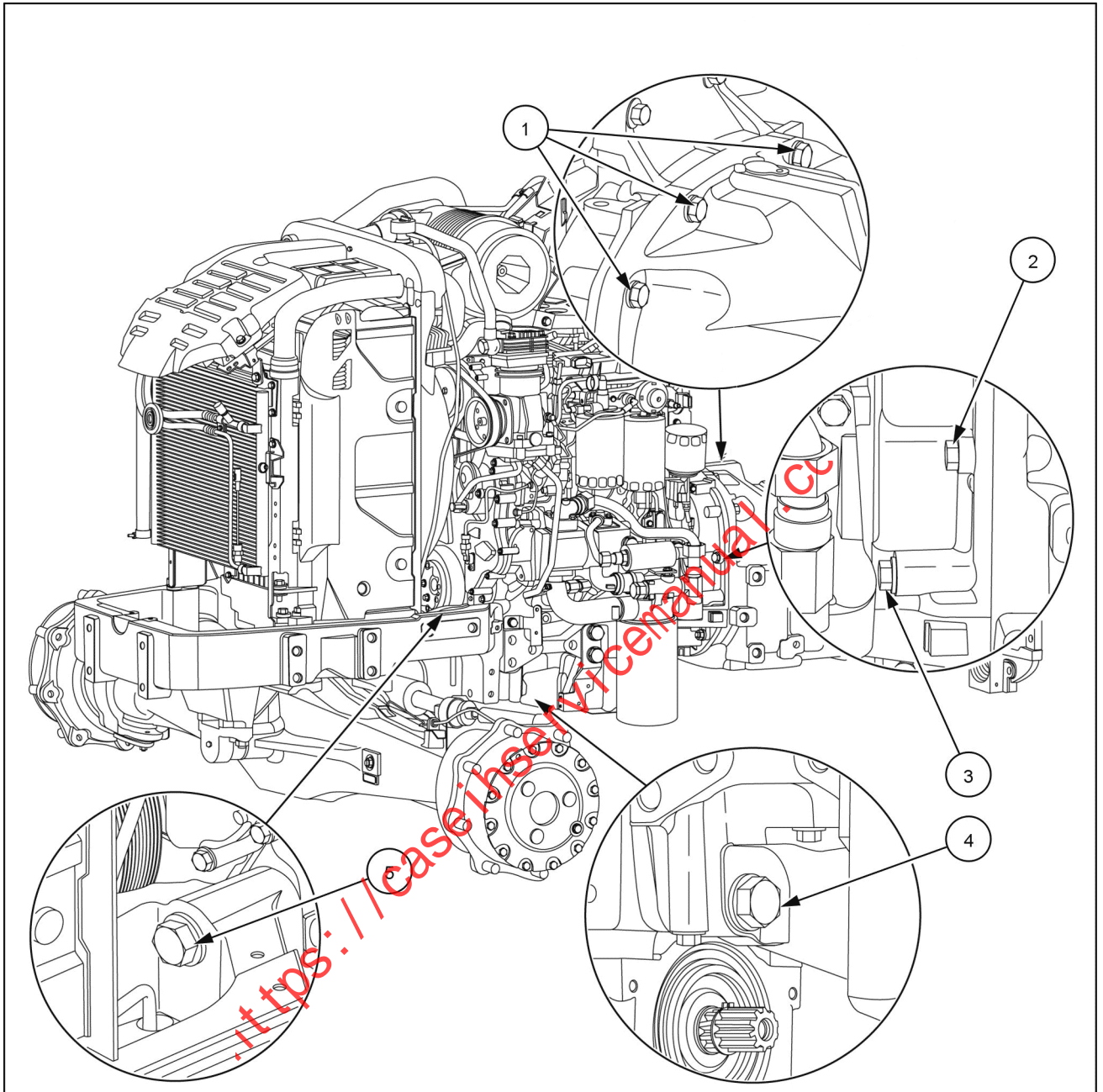

MOIL17TR00673GA 1

Part to tighten	Thread	Tighten torque
Bolt (5) securing the front axle to the engine block	M20 x 1.5 x 130	587 N·m (432.95 lb ft)
Bolt (4) securing the engine block to the front axle	M20 x 1.5 x 110	587 N·m (432.95 lb ft)
Bolt (1) securing the gearbox to the engine block	M12 x 1.25 x 50	121 N·m (89.25 lb ft)
Bolt (2) securing the engine block to the gearbox	M12 x 1.25 x 50	121 N·m (89.25 lb ft)
Bolt (3) securing the engine block to the gearbox	M12 x 1.25 x 90	121 N·m (89.25 lb ft)