

<https://caseih.servicemanual.com>

OPTUM[®] 270 CVT
OPTUM[®] 300 CVT
TIER 4B (FINAL)
Tractor

PIN ZFEM01001 and above

SERVICE MANUAL

Part number 48193161

English

November 2017

© 2017 CNH Industrial Österreich GmbH. All Rights Reserved.

CASE IH
AGRICULTURE



SERVICE MANUAL

OPTUM® 270 CVT - [ZFEM01001 - ZGEM02931], OPTUM® 270 CVT - [ZGEM02932 - ZGEM04528], OPTUM® 270 CVT - [ZGEM04529 -], OPTUM® 300 CVT - [ZFEM01001 - ZGEM02931], OPTUM® 300 CVT - [ZGEM02932 - ZGEM04528], OPTUM® 300 CVT - [ZGEM04529 -]

<https://caseihservicemanual.com>

Link Product / Engine

Product	Market Product	Engine
OPTUM® 270 CVT - [ZFEM01001 - ZGEM02931]	North America	F4DFE617M*B001
OPTUM® 270 CVT - [ZGEM02932 - ZGEM04528]	North America	F4DFE617M*B001
OPTUM® 270 CVT - [ZGEM04529 -]	North America	F4DFE617M*B001
OPTUM® 300 CVT - [ZFEM01001 - ZGEM02931]	North America	F4DFE617L*B002
OPTUM® 300 CVT - [ZGEM02932 - ZGEM04528]	North America	F4DFE617L*B002
OPTUM® 300 CVT - [ZGEM04529 -]	North America	F4DFE617L*B002

<https://caseih.servicemanual.com>

Contents

INTRODUCTION

Engine.....	10
[10.001] Engine and crankcase	10.1
[10.216] Fuel tanks	10.2
[10.202] Air cleaners and lines	10.3
[10.254] Intake and exhaust manifolds and muffler	10.4
[10.500] Selective Catalytic Reduction (SCR) exhaust treatment.....	10.5
[10.400] Engine cooling system	10.6
[10.414] Fan and drive	10.7
[10.310] Aftercooler.....	10.8
Clutch	18
[18.112] Slip clutch or flywheel damper	18.1
Transmission.....	21
[21.504] Continuously Variable Transmission (CVT)	21.1
[21.505] Continuously Variable Transmission (CVT) external controls.....	21.2
[21.506] Continuously Variable Transmission (CVT) hydraulic components	21.3
[21.507] Continuously Variable Transmission (CVT) internal components.....	21.4
Four-Wheel Drive (4WD) system	23
[23.202] Electro-hydraulic control	23.1
[23.314] Drive shaft.....	23.2
Front axle system	25
[25.100] Powered front axle	25.1
[25.102] Front bevel gear set and differential	25.2
[25.108] Final drive hub, steering knuckles, and shafts	25.3
[25.122] Axle suspension control.....	25.4
Rear axle system.....	27

[27.100] Powered rear axle.....	27.1
[27.106] Rear bevel gear set and differential.....	27.2
[27.120] Planetary and final drives	27.3
Power Take-Off (PTO).....	31
[31.104] Rear electro-hydraulic control.....	31.1
[31.119] Four-speed rear Power Take-Off (PTO).....	31.2
[31.142] Front Power Take-Off (PTO) control	31.3
[31.146] Front Power Take-Off (PTO)	31.4
Brakes and controls	33
[33.202] Hydraulic service brakes	33.1
[33.110] Parking brake or parking lock	33.2
[33.240] Emergency brake	33.3
[33.220] Trailer brake hydraulic control.....	33.4
[33.224] Trailer brake pneumatic control	33.5
[33.204] Front axle brake	33.6
[33.200] Brake cooling.....	33.7
[33.350] Anti-lock Brake System (ABS).....	33.8
Hydraulic systems.....	35
[35.000] Hydraulic systems.....	35.1
[35.300] Reservoir, cooler, and filters.....	35.2
[35.106] Variable displacement pump	35.3
[35.230] Priority valves	35.4
[35.204] Remote control valves	35.5
[35.220] Auxiliary hydraulic pump	35.6
[35.114] Three-point hitch control valve	35.7
[35.116] Three-point hitch cylinder	35.8
[35.124] Three-point hitch hydraulic adjustment	35.9
[35.160] Front hitch controls and lines	35.10

[35.162] Front hitch cylinders and lines	35.11
Hitches, drawbars, and implement couplings.....	37
[37.100] Drawbars and towing hitches	37.1
[37.106] Automatic pickup hitch	37.2
[37.162] Front hitch	37.3
Frames and ballasting	39
[39.100] Frame	39.1
[39.140] Ballasts and supports	39.2
Steering.....	41
[41.101] Steering control	41.1
[41.106] Tie rods.....	41.2
[41.200] Hydraulic control components.....	41.3
[41.216] Cylinders	41.4
[41.432] Autoguidance steering	41.5
Wheels	44
[44.511] Front wheels.....	44.1
[44.520] Rear wheels	44.2
Cab climate control.....	50
[50.100] Heating	50.1
[50.104] Ventilation	50.2
[50.200] Air conditioning.....	50.3
Electrical systems	55
[55.045] Front axle control system	55.1
[55.000] Electrical system	55.2
[55.100] Harnesses and connectors.....	55.3
[55.015] Engine control system.....	55.4
[55.301] Alternator.....	55.5

[55.302] Battery.....	55.6
[55.988] Selective Catalytic Reduction (SCR) electrical system	55.7
[55.640] Electronic modules	55.8
[55.513] Cab transmission controls.....	55.9
[55.024] Transmission control system	55.10
[55.020] Transmission speed sensors.....	55.11
[55.021] Transmission pressure sensors	55.12
[55.022] Transmission temperature sensors	55.13
[55.023] Transmission position sensors and switches	55.14
[55.048] Rear Power Take-Off (PTO) control system	55.15
[55.049] Front Power Take-Off (PTO) control system	55.16
[55.519] Cab brake controls	55.17
[55.031] Parking brake electrical system	55.18
[55.512] Cab controls.....	55.19
[55.035] Remote control valve electric control	55.20
[55.051] Cab Heating, Ventilation, and Air-Conditioning (HVAC) controls.....	55.21
[55.050] Heating, Ventilation, and Air-Conditioning (HVAC) control system.....	55.22
[55.047] Steering control system	55.23
[55.130] Rear three-point hitch electronic control system	55.24
[55.160] Front hitch electronic control system.....	55.25
[55.911] Satellite navigation systems.....	55.26
[55.404] External lighting	55.27
[55.510] Cab or platform harnesses and connectors.....	55.28
[55.408] Warning indicators, alarms, and instruments	55.29
[55.550] Tire Pressure Monitoring System (TPMS)	55.30
[55.350] Anti-lock Brake System (ABS) electrical system.....	55.31
[55.DTC] FAULT CODES.....	55.32

Platform, cab, bodywork, and decals..... 90

[90.150] Cab.....	90.1
-------------------	------

[90.156] Cab windshield and windows	90.2
[90.100] Engine hood and panels	90.3

<https://caseihservicemanual.com>

<https://caseihservicemanual.com>



INTRODUCTION

<https://caseih.servicemanual.com>

Contents

INTRODUCTION

Foreword - How to use and navigate through this manual	3
Foreword - Important notice regarding equipment servicing	8
Torque	9
Torque - Standard torque data for hydraulic connections	14
Capacities	21
Consumables	22

<https://caseihservicemanual.com>

Foreword - How to use and navigate through this manual

This manual has been produced by a new technical information system. This new system is designed to deliver technical information electronically through web delivery (eTIM), DVD, and paper manuals. A coding system called SAP has been developed to link the technical information to other Product Support functions, e.g., Warranty.

Technical information is written to support the maintenance and service of the functions or systems on a customer's machine. When a customer has a concern on their machine it is usually because a function or system on their machine is not working at all, is not working efficiently, or is not responding correctly to their commands. When you refer to the technical information in this manual to resolve that customer's concern, you will find all the information classified using the SAP coding, according to the functions or systems on that machine. Once you have located the technical information for that function or system, you will then find all the mechanical, electrical or hydraulic devices, components, assemblies, and sub assemblies for that function or system. You will also find all the types of information that have been written for that function or system: the technical data (specifications), the functional data (how it works), the diagnostic data (fault codes and troubleshooting), and the service data (remove, install adjust, etc.).

By integrating SAP coding into technical information, you will be able to search and retrieve just the right piece of technical information you need to resolve that customer's concern on his machine. This is made possible by attaching 3 categories to each piece of technical information during the authoring process.

The first category is the Location, the second category is the Information Type and the third category is the Product:

- LOCATION - the component or function on the machine, that the piece of technical information is going to describe (e.g., Fuel tank).
- INFORMATION TYPE - the piece of technical information that has been written for a particular component or function on the machine (e.g., Capacity would be a type of Technical Data describing the amount of fuel held by the fuel tank).
- PRODUCT - the model for which the piece of technical information is written.

Every piece of technical information will have those three categories attached to it. You will be able to use any combination of those categories to find the right piece of technical information you need to resolve that customer's concern on their machine.

That information could be:

- the procedure for how to remove the cylinder head
- a table of specifications for a hydraulic pump
- a fault code
- a troubleshooting table
- a special tool

Manual content

This manual is divided into Sections. Each Section is then divided into Chapters. Contents pages are included at the beginning of the manual, then inside every Section and inside every Chapter. An alphabetical Index is included at the end of each Chapter. Page number references are included for every piece of technical information listed in the Chapter Contents or Chapter Index.

Each Chapter is divided into four Information types:

- Technical Data (specifications) for all the mechanical, electrical or hydraulic devices, components, assemblies or sub-assemblies.
- Functional Data (how it works) for all the mechanical, electrical or hydraulic devices, components, assemblies or sub-assemblies.
- Diagnostic Data (fault codes, electrical and hydraulic troubleshooting) for all the mechanical, electrical or hydraulic devices, components, assemblies or sub-assemblies.
- Service Data (remove disassemble, assemble, install) for all the mechanical, electrical or hydraulic devices, components, assemblies or sub-assemblies.

Sections

Sections are grouped according to the main functions or a systems on the machine. Each Section is identified by a number (00, 35, 55, etc.). The Sections included in the manual will depend on the type and function of the machine that the manual is written for. Each Section has a Contents page listed in alphabetic/numeric order. This table illustrates which Sections could be included in a manual for a particular product.

SECTION	PRODUCT				
	Tractors				
	Vehicles with working arms: backhoes, excavators, skid steers,				
	Combines, forage harvesters, balers,				
	Seeding, planting, floating, spraying equipment,				
	Mounted equipment and tools,				
00 - Maintenance	X	X	X	X	X
05 - Machine completion and equipment	X	X	X	X	X
10 - Engine	X	X	X	X	
14 - Main gearbox and drive	X	X	X	X	
18 - Clutch	X	X	X		
21 - Transmission	X	X	X	X	
23 - Four wheel drive (4WD) system	X	X	X	X	
25 - Front axle system	X	X	X	X	
27 - Rear axle system	X	X	X	X	
29 - Hydrostatic drive	X	X	X	X	
31 - Power Take-Off (PTO)	X		X		
33 - Brakes and controls	X	X	X	X	
35 - Hydraulic systems	X	X	X	X	
36 - Pneumatic system	X	X	X	X	
37 - Hitches, drawbars and implement couplings	X		X	X	
39 - Frames and ballasting	X	X	X	X	X
41 - Steering	X	X	X	X	
44 - Wheels	X	X	X	X	
46 - Steering clutches					
48 - Tracks and track suspension	X	X	X		
50 - Cab climate control	X	X	X	X	
55 - Electrical systems	X	X	X	X	X
56 - Grape harvester shaking					
58 - Attachments/headers			X		
60 - Product feeding			X		

INTRODUCTION

61 - Metering system				X	
62 - Pressing - Bale formation			X		
63 - Chemical applicators				X	
64 - Chopping			X		
66 - Threshing			X		
68 - Tying/Wrapping/Twisting			X		
69 - Bale wagons					
70 - Ejection			X		
71 - Lubrication system	X	X	X	X	X
72 - Separation			X		
73 - Residue handling			X		
74 - Cleaning			X		
75 - Soil preparation/Finishing					
76 - Secondary cleaning / Destemmer					
77 - Seeding				X	
78 - Spraying				X	
79 - Planting				X	
80 - Crop storage / Unloading			X		
82 - Front loader and bucket	X	X			
83 - Telescopic single arm	X	X			
84 - Booms, dippers and buckets	X	X			
86 - Dozer blade and arm	X	X			
88 - Accessories	X	X	X	X	X
89 - Tools	X	X	X	X	X
90 - Platform, cab, bodywork and decals	X	X	X	X	

<https://caseih.servicematerial.com>

Chapters

Each Chapter is identified by a number e.g. Engine - Engine and crankcase - 10.001. The first number is identical to the Section number i.e. Chapter 10.001 is inside Section 10, Engine. The second number is representative of the Chapter contained within the Section.

CONTENTS

The Chapter Contents lists all the technical data (specifications), functional data (how it works), diagnostic data (fault codes and troubleshooting), and service data (remove, install, adjust, etc.), that have been written in that Chapter for that function or system on the machine.

Contents

ENGINE

ENGINE - Engine and crankcase – 10.001

TECHNICAL DATA

ENGINE - Engine and crankcase - General specification (10.001 - D.40.A.10)	4
--	---

FUNCTIONAL DATA

ENGINE - Engine and crankcase - Dynamic description (10.001 - C.30.A.10)	6
--	---

SERVICE

ENGINE - Engine and crankcase - Remove (10.001 -F.10.A.10)	8
--	---

DIAGNOSTIC

ENGINE - Engine and crankcase - Troubleshooting (10.001 - G.40.A.10)	10
--	----

INDEX

The Chapter Index lists in alphabetical order all the types of information (called information units) that have been written in that Chapter for that function or system on the machine.

Index

ENGINE - 10

ENGINE

ENGINE - Engine and crankcase - Dynamic description (10.001 - C.30.A.10)	6
--	---

ENGINE - Engine and crankcase - General specification (10.001 - D.40.A.10)	4
--	---

ENGINE - Engine and crankcase - Remove (10.001 -F.10.A.10)	8
--	---

ENGINE - Engine and crankcase - Troubleshooting (10.001 - G.40.A.10)	10
--	----

Information units and information search

Each chapter is composed of information units. Each information unit has the SAP code shown in parentheses. This indicates the function and type of information in that information unit. Each information unit has a page reference within that Chapter. The information units provide a quick and easy way to find just the right piece of technical information you are looking for.

Example information unit	Engine block cover - Front – Remove (10.102.AP.01 - F.10.A.10)					
Information Unit SAP code	10	102	AK	01	F	10.A.10
SAP code classification	Engine	Pan and covers	Engine block cover	Front	Service data	Remove

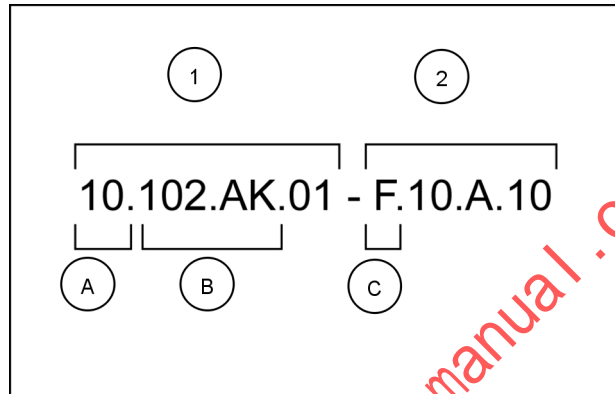

NHIL12GEN0070A 1

Navigate to the correct information unit you are searching for by identifying the function and information type from the SAP code.

- **(1)** Location and **(2)** Information type.
- **(A)** corresponds to the sections of the service manual.
(B) corresponds to the chapters of the service manual. After **(B)** there may be some additional information. In this case it shows “.01”, which represents the “Front” block cover. These options may be front/rear, left/right, hydraulic/mechanical etc.
(C) corresponds to the type of information listed in the chapter contents: Technical Data, Functional Data, Diagnostic, or Service.
(A) and **(B)** are also shown in the page numbering on the page footer.
THE REST OF THE CODING IS NOT LISTED IN ALPHANUMERIC ORDER IN THIS MANUAL.
- You will find a table of contents at the beginning and end of each section and chapter.
You will find an alphabetical index at the end of each chapter.
- By referring to **(A)**, **(B)** and **(C)** of the coding, you can follow the contents or index (page numbers) and quickly find the information you are looking for.

Page header and footer

The page header will contain the following references:

- Section and Chapter description

The page footer will contain the following references:

- Publication number for that Manual.
- Version reference for that publication.
- Publication date
- Section, chapter, and page reference e.g. 10.102 / 9

Foreword - Important notice regarding equipment servicing

All repair and maintenance work listed in this manual must be carried out only by qualified dealership personnel, strictly complying with the instructions given, and using, whenever possible, the special tools.

Anyone who performs repair and maintenance operations without complying with the procedures provided herein shall be responsible for any subsequent damages.

The manufacturer and all the organizations of its distribution chain, including - without limitation - national, regional, or local dealers, reject any responsibility for damages caused by parts and/or components not approved by the manufacturer, including those used for the servicing or repair of the product manufactured or marketed by the manufacturer. In any case, no warranty is given or attributed on the product manufactured or marketed by the manufacturer in case of damages caused by parts and/or components not approved by the manufacturer.

The manufacturer reserves the right to make improvements in design and changes in specifications at any time without notice and without incurring any obligation to install them on units previously sold. Specifications, descriptions, and illustrative material herein are as accurate as known at time of publication but are subject to change without notice.

In case of questions, refer to your CASE IH Sales and Service Networks.

<https://caseihservicemanual.com>

Torque

NOTE: In the metric tables, nominal sizes M4 through M8 hardware torque specifications are shown as a Newton meters (pound-inches) numerical value.

Nominal sizes M10 through M24 hardware torque specifications are shown as a Newton meters (pound-feet) numerical value.

Metric hex head (non-flange) hardware

Plain (PLN) – an unplated hardware finish with residual manufacturing oils

Zinc-dichromate (ZND) – a yellow colored chemical plating formula yellow applied to the hardware

Nominal size	Class (CL) 8.8 bolt and Class (CL) 8 nut	Class (CL) 10.9 bolt and Class (CL) 10 nut	Locknut CL 8 w/CL 8.8 bolt	Locknut CL 10 w/CL 10.9 bolt
	PLN and ZND	PLN and ZND	ZND	ZND
	N·m (lb in)	N·m (lb in)	N·m (lb in)	N·m (lb in)
M4	3.5 (31)	5.0 (44)	1.4 (13)	2.8 (25)
M5	7.0 (62)	10 (88)	2.9 (26)	5.5 (49)
M6	11.8 (104)	17 (150)	4.9 (43)	9.4 (83)
M8	28.8 (255)	41.3 (366)	11.9 (105)	23 (204)
	N·m (lb ft)	N·m (lb ft)	N·m (lb ft)	N·m (lb ft)
M10	57 (42)	82 (60)	24 (17)	45 (33)
M12	100 (74)	143 (105)	41 (30)	79 (38)
M14	159 (117)	227 (168)	66 (48)	125 (92)
M16	248 (183)	354 (261)	102 (75)	195 (144)
M18	352 (260)	487 (359)	145 (107)	268 (198)
M20	500 (369)	690 (509)	206 (152)	380 (280)
M24	865 (638)	1195 (882)	357 (263)	657 (485)

Metric flange head hardware

Plain (PLN) – an unplated hardware finish with residual manufacturing oils

Zinc-dichromate (ZND) – a yellow colored chemical plating formula yellow applied to the hardware

Nominal size	Class (CL) 8.8 bolt and Class (CL) 8 nut	Class (CL) 10.9 bolt and Class (CL) 10 nut	Flange locknut CL 8 w/CL 8.8 bolt	Flange locknut CL 10 w/CL 10.9 bolt
	PLN and ZND	PLN and ZND	ZND	ZND
	N·m (lb in)	N·m (lb in)	N·m (lb in)	N·m (lb in)
M4	3.8 (34)	5.5 (49)	4.2 (37)	6.1 (54)
M5	7.7 (68)	11 (97)	8.5 (75)	12 (106)
M6	13 (115)	18.7 (166)	14.3 (127)	20.6 (182)
M8	31.7 (281)	45.5 (403)	35 (310)	50 (443)
	N·m (lb ft)	N·m (lb ft)	N·m (lb ft)	N·m (lb ft)
M10	63 (47)	90 (66)	69 (51)	99 (73)
M12	110 (81)	157 (116)	121 (89)	173 (128)
M14	175 (129)	250 (184)	193 (142)	275 (202)
M16	272 (201)	389 (287)	299 (221)	428 (316)
M18	387 (286)	535 (395)	426 (315)	589 (435)
M20	550 (406)	759 (560)	605 (447)	835 (616)
M24	951 (702)	1315 (970)	1046 (772)	1447 (1067)

Identification markings

Metric hex head, flange hex head and carriage bolts, Classes (CL) 5.6 and upward

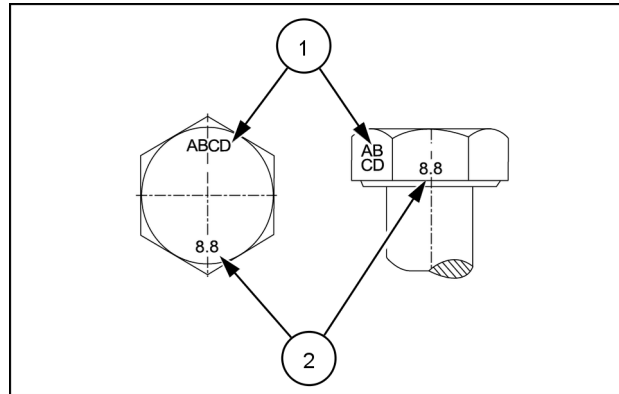

NHIL14RB00662AA 1

Metric bolt identification markings

1. Manufacturer's identification
2. Property class

Metric hex nuts and locknuts, Classes (CL) 05 and upward

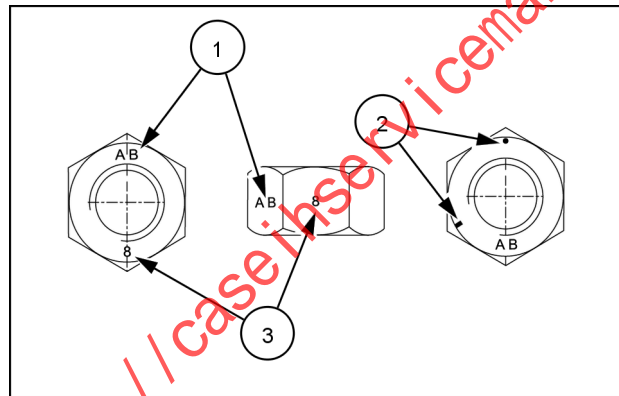

NHIL14RB00663AA 2

Metric hex nut identification markings

- **(1)** – Manufacturer's identification
- **(3)** – Property class
- **(2)** – Clockwise type markings indicate property class and may include manufacturer identification (if applied), Example: property marks **240°** apart (shown) at the eight o'clock position indicate a Class 8 property, and marks **300°** apart at the ten o'clock position indicate a Class 10 property.

INTRODUCTION

NOTE: In the Imperial units tables, the nominal sizes, **1/4 (0.25) in (inch)** and **5/16 (0.3125) in (inch)** hardware torque specifications are shown as a Newton meters (pound-inches) numerical value.
Nominal sizes **3/8 (0.375) in (inch)** through **1 (1.0) in (inch)** hardware torque specifications are shown as a Newton meters (pound-feet) numerical value.

Inch hex head (non-flange) hardware

Plain (PLN) – an unplated hardware finish with residual manufacturing oils

Zinc-dichromate (ZND) – a yellow colored chemical plating formula yellow applied to the hardware

Nominal size	SAE Grade (GR) 5 bolt and nut	SAE Grade (GR) 8 bolt and nut	Locknut GR B w/ GR 5 bolt	Locknut GR C w/ GR 8 bolt
	PLN and ZND	PLN and ZND	ZND	ZND
	N·m (lb in)	N·m (lb in)	N·m (lb in)	N·m (lb in)
1/4 (0.25) in	13 (115)	18 (159)	7.2 (64)	10 (89)
5/16 (0.3125) in	27 (239)	38 (336)	14.9 (132)	21 (186)
	N·m (lb ft)	N·m (lb ft)	N·m (lb ft)	N·m (lb ft)
3/8 (0.375) in	47 (35)	67 (49)	26 (19)	37 (27)
7/16 (0.4375) in	76 (56)	107 (79)	42 (31)	59 (44)
1/2 (0.50) in	116 (85)	164 (121)	64 (47)	90 (67)
9/16 (0.5625) in	167 (123)	236 (174)	92 (68)	130 (96)
5/8 (0.625) in	231 (170)	326 (240)	127 (94)	179 (132)
3/4 (0.75) in	410 (302)	578 (426)	226 (166)	318 (234)
7/8 (0.875) in	660 (486)	931 (687)	363 (267)	512 (378)
1 (1.0) in	989 (729)	1396 (1030)	544 (401)	768 (567)

Inch flange head hardware

Plain (PLN) – an unplated hardware finish with residual manufacturing oils









Zinc-dichromate (ZND) – a yellow colored chemical plating formula yellow applied to the hardware

Nominal size	SAE Grade (GR) 5 bolt and nut	SAE Grade (GR) 8 bolt and nut	Flange locknut GR F w/ GR 5 bolt	Flange locknut GR G w/ GR 8 bolt
	PLN and ZND	PLN and ZND	ZND	ZND
	N·m (lb in)	N·m (lb in)	N·m (lb in)	N·m (lb in)
1/4 (0.25) in	14 (124)	20 (177)	15.4 (136)	22 (195)
5/16 (0.3125) in	29 (257)	42 (372)	32 (283)	46 (407)
	N·m (lb ft)	N·m (lb ft)	N·m (lb ft)	N·m (lb ft)
3/8 (0.375) in	52 (38)	74 (54)	57 (42)	81 (9)
7/16 (0.4375) in	84 (62)	118 (87)	92 (68)	130 (96)
1/2 (0.50) in	127 (94)	180 (133)	140 (103)	198 (146)
9/16 (0.5625) in	184 (136)	259 (191)	202 (150)	285 (210)
5/8 (0.625) in	254 (187)	358 (264)	279 (206)	394 (290)
3/4 (0.75) in	450 (332)	636 (469)	495 (365)	700 (516)
7/8 (0.875) in	725 (535)	1024 (755)	798 (589)	1126 (831)
1 (1.0) in	1088 (802)	1536 (1133)	1197 (882)	1690 (1246)

Identification marking

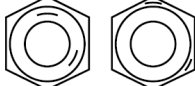
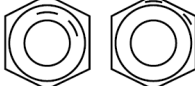
Grades of inch bolts and free-spinning nuts







SAE (J995) bolt head and nut grade identification

Grade identification marking	Grade Marking description
	Grade 2 No line marks
	Grade 5 Three line marks
	Grade 8 Six line marks
	Grade 2 No circumferential line marks
	Grade 5 Two circumferential line marks located 120° apart
	Grade 2 Two circumferential line marks located 60° apart
	Grade 2 No circumferential line marks
	Grade 5 Two circumferential line marks located 120° apart
	Grade 8 Two circumferential line marks located 60° apart

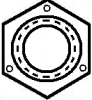
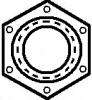
Grades of inch prevailing torque locknuts, all metal (three common marking methods)

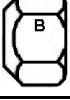
On prevailing torque locknuts, the grade of nut is identified by one of three different sets of markings that denote the strength level and manufacturer.

Common prevailing torque locknut grade identification markings

Grade identification marking	Grade Marking description
	<p>Grade A No marks</p>
	<p>Grade B (hex nut) and Grade F (flange nut) Three raised or indented dot marks (Marks do not have to be in corners.)</p>
	<p>Grade C (hex nut) and Grade F (flange nut) Six raised or indented dot marks (Marks do not have to be in corners.)</p>
	<p>Grade A No letter mark on side flat</p>
	<p>Grade B Letter B on side flat</p>
	<p>Grade C Letter C on side flat</p>
	<p>Grade A No notches</p>
	<p>Grade B One circumferential notch on all six corners</p>
	<p>Grade C Two circumferential notches on all six corners</p>

Torque - Standard torque data for hydraulic connections

General information

- Hydraulic connections require a minimum assembly torque in order to provide zero leakage at rated pressure with adequate fatigue resistance. Over-torquing of a hydraulic connection can also lead to leakage or failure. For some connections, CASE IH requires a different torque value than is listed in the ISO and SAE standards.
- The torque values in this document should be used whenever possible or applicable.

NOTICE: Always follow the instructions in this manual for specific torque values when you service components. The information in this section is for general guidance only when a procedure contains no specific torque value.

Tolerance

- The tolerance for all torque values is $\pm 10\%$. This tolerance must include all assembly variation, not only the torque wrench repeatability.

Lubrication

Application of grease or other lubricants to hydraulic connectors should be avoided. If clean hydraulic oil is already on the connection, it is not required to remove the oil. Generally, application of grease:

- May cause a significant change in the torque required to properly tighten the connection.
- May reduce the connection's resistance to vibration.
- Excessive grease may displace an elastomer seal during tightening.
- Grease extrusion when connection is tightened may be mistaken for leakage.

CASE IH products generally use O-Ring Boss (ORB) connectors that have Teflon™-coated O-rings, eliminating the need for O-ring lubrication during installation. For connections which are made into aluminum manifolds or with stainless steel connectors, it may be required to apply a lubricant to prevent galling.

Use of **LOCTITE®** and other thread-locking compounds is prohibited. These compounds:

- May cause a significant change in the torque required to properly tighten the connections.
- Reduce the serviceability of the joint.
- May prevent the O-ring from properly sealing if the compound gets on the O-ring.

Torque values for metric O-Ring Boss (ORB) port connections

Metric thread	S-Series *		L-Series **	
	Ferrous N·m (lb ft) ± 10%	Non-Ferrous N·m (lb ft) ± 10%	Ferrous N·m (lb ft) ± 10%	Non-Ferrous N·m (lb ft) ± 10%
M8 x 1	10.5 (7.7)	6.3 (4.6)	8.5 (6.3)	5 (3.7)
M10 x 1	21 (15.5)	12.5 (9.2)	15.5 (11.4)	9.3 (6.9)
M12 x 1.5	37 (27.3)	22 (16.2)	27 (19.9)	16 (11.8)
M14 x 1.5	47 (34.7)	28 (20.7)	37 (27.3)	22 (16.2)
M16 x 1.5	58 (42.8)	35 (25.8)	42 (31)	25 (18.4)
M18 x 1.5	74 (54.6)	44 (32.5)	47 (34.7)	28 (20.7)
M22 x 1.5	105 (77.4)	63 (46.5)	63 (46.5)	38 (28)
M27 x 2	178 (131.3)	107 (78.9)	105 (77.4)	63 (46.5)
M30 x 2	225 (166)	135 (99.6)	136 (100.3)	82 (60.5)
M33 x 2	325 (239.7)	195 (143.8)	168 (123.9)	101 (74.5)
M42 x 2	345 (254.5)	207 (152.7)	220 (162.3)	132 (97.4)
M48 x 2	440 (324.5)	264 (194.7)	273 (201.4)	164 (121)
M60 x 2	525 (387.2)	315 (232.3)	330 (243.4)	198 (146)

* S-Series connectors are used with O-Ring Face Seals (ORFS).

** L-Series connectors are used with 37° flare.

Torque values for metric O-Ring Boss (ORB) port plugs

Metric thread	Ferrous		Non-ferrous N·m (lb ft) ± 10%
	Internal hex N·m (lb ft) ± 10%	External hex N·m (lb ft) ± 10%	
M8 x 1	8.5 (6.3)	10.5 (7.7)	6.3 (4.6)
M10 x 1	16 (11.8)	21 (15.5)	12.5 (9.2)
M12 x 1.5	23 (17)	37 (27.3)	22 (16.2)
M14 x 1.5	47 (34.7)	47 (34.7)	28 (20.7)
M16 x 1.5	58 (42.8)	58 (42.8)	35 (25.8)
M18 x 1.5	74 (54.6)	74 (54.6)	44 (32.5)
M22 x 1.5	105 (77.4)	105 (77.4)	63 (46.5)
M27 x 2	178 (131.3)	178 (131.3)	107 (78.9)
M30 x 2	225 (166)	225 (166)	135 (99.6)
M33 x 2	325 (239.7)	325 (239.7)	195 (143.8)
M42 x 2	345 (254.5)	345 (254.5)	207 (152.7)
M48 x 2	440 (324.5)	440 (324.5)	264 (194.7)
M60 x 2	525 (387.2)	525 (387.2)	315 (232.3)

INTRODUCTION

Torque values for port connections (British Standard Pipe Parallel (BSPP) thread ports and stud ends)

BSPP thread G- Gas; A- medium coarse threads	Metric tube Outside Diameter (OD) mm (in)		Ferrous		Non-Ferrous	
	S-Series *	L-Series **	S-Series N·m (lb ft) ± 10%	L-Series N·m (lb ft) ± 10%	S-Series N·m (lb ft) ± 10%	L-Series N·m (lb ft) ± 10%
G 1/8 A	–	6 (0.236)	–	21 (15.5)	–	12.5 (9.2)
G 1/4 A	6 (0.236) or 8 (0.315)	8 (0.315) or 10 (0.394)	63 (46.5)	53 (39.1)	38 (28)	32 (23.6)
G 3/8 A	10 (0.394) or 12 (0.472)	12 (0.472)	95 (70.1)	84 (62)	57 (42)	50 (36.9)
G 1/2 A	16 (0.630)	15 (0.591) or 18 (0.709)	136 (100.3)	105 (77.4)	82 (60.5)	63 (46.5)
G 3/4 A	20 (0.787)	22 (0.866)	210 (154.9)	210 (154.9)	126 (92.9)	126 (92.9)
G 1 A	25 (0.984)	28 (1.102)	400 (295)	400 (295)	240 (177)	240 (177)
G 1 1/4 A	30 (1.181)	35 (1.378)	525 (387.2)	525 (387.2)	315 (232.3)	315 (232.3)
G 1 1/2 A	38 (1.496)	42 (1.654)	660 (486.8)	660 (486.8)	396 (292.1)	396 (292.1)

* S-Series connectors are used with O-Ring Face Seals (ORFS).

** L-Series connectors are used with 37° flare.

Torque values for metric port connections (Metric face-seal ports and stud ends)

Metric thread	Metric tube Outside Diameter (OD) mm (in)		Ferrous		Non-Ferrous	
	S-Series *	L-Series **	S-Series N·m (lb ft) ± 10%	L-Series N·m (lb ft) ± 10%	S-Series N·m (lb ft) ± 10%	L-Series N·m (lb ft) ± 10%
M10 x 1	–	4 (0.157)	–	21 (15.5)	–	12.5 (9.2)
M12 x 1.5	4 (0.157)	6 (0.236)	47 (34.7)	32 (23.6)	28 (20.7)	19 (14)
M14 x 1.5	5 (0.197)	7 (0.276)	63 (46.5)	53 (39.1)	38 (28)	32 (23.6)
M16 x 1.5	7 (0.276)	9 (0.354)	84 (62)	63 (46.5)	50 (36.9)	38 (28)
M18 x 1.5	8 (0.315)	11 (0.433)	105 (77.4)	84 (62)	63 (46.5)	50 (36.9)
M20 x 1.5	10 (0.394)	–	147 (108.4)	–	88 (64.9)	–
M22 x 1.5	12 (0.472)	14 (0.551)	158 (116.5)	147 (108.4)	95 (70.1)	88 (64.9)
M26 x 1.5	–	18 (0.709)	–	210 (154.9)	–	126 (92.9)
M27 x 1.2	16 (0.630)	–	210 (154.9)	–	126 (92.9)	–
M33 x 2	20 (0.787)	23 (0.906)	400 (295)	400 (295)	240 (177)	240 (177)
M42 x 2	25 (0.984)	30 (1.181)	525 (387.2)	525 (387.2)	315 (232.3)	315 (232.3)
M48 x 2	32 (1.260)	36 (1.417)	630 (464.7)	630 (464.7)	396 (292.1)	396 (292.1)

* S-Series connectors are used with O-Ring Face Seals (ORFS).

** L-Series connectors are used with 37° flare.

Torque values for Inch O-Ring Boss (ORB) port non-adjustable connections

SAE dash size	UN/UNF thread size	Inch tube OD mm (in)	S-Series *		L-Series **	
			Ferrous N·m (lb ft) ± 10%	Non-Ferrous N·m (lb ft) ± 10%	Ferrous N·m (lb ft) ± 10%	Non-Ferrous N·m (lb ft) ± 10%
2	5/16-24	3.18 (0.125)	–	–	8.5 (6.3)	5 (3.7)
3	3/8-24	4.76 (0.187)	15.5 (11.4)	9.3 (6.9)	10.5 (7.7)	6.3 (4.6)
4	7/16-20	6.35 (0.250)	37 (27.3)	22 (16.2)	19 (14)	11.5 (8.5)
5	1/2-20	7.94 (0.313)	42 (31)	25 (18.4)	26 (19.2)	15.5 (11.4)
6	9/16-18	9.52 (0.375)	47 (34.7)	28 (20.7)	32 (23.6)	19 (14)
8	3/4-16	12.7 (0.500)	89 (65.6)	53 (39.1)	53 (39.1)	32 (23.6)
10	7/8-14	15.88 (0.625)	121 (89.2)	73 (53.8)	63 (46.5)	38 (28)
12	1-1/16-12	19.05 (0.750)	178 (131.3)	107 (78.9)	100 (73.8)	60 (44.3)
14	1-3/16-12	22.22 (0.875)	225 (166)	135 (99.6)	131 (96.6)	79 (58.3)
16	1-5/16-12	25.4 (1.000)	283 (208.7)	170 (125.4)	156 (115.1)	94 (69.3)
20	1-5/8-12	31.75 (1.250)	300 (221.3)	180 (132.8)	210 (154.9)	126 (92.9)
24	1-7/8-12	38.1 (1.500)	388 (286.2)	233 (171.9)	220 (162.3)	132 (97.4)
32	2-1/2-12	50.8 (2.000)	388 (286.2)	233 (171.9)	315 (232.3)	189 (139.4)

* S-Series connectors are used with O-Ring Face Seals (ORFS).

** L-Series connectors are used with 37° flare.

Torque values for inch O-Ring Boss (ORB) port adjustable connections

SAE dash size	UN/UNF thread size	Inch tube OD mm (in)	S-Series *		L-Series **	
			Ferrous N·m (lb ft) ± 10%	Non-Ferrous N·m (lb ft) ± 10%	Ferrous N·m (lb ft) ± 10%	Non-Ferrous N·m (lb ft) ± 10%
2	5/16-24	3.18 (0.125)	–	–	8.5 (6.3)	5 (3.7)
3	3/8-24	4.76 (0.187)	10.5 (7.7)	9.3 (6.9)	10.5 (7.7)	6.3 (4.6)
4	7/16-20	6.35 (0.250)	21 (15.5)	21 (15.5)	19 (14)	11.5 (8.5)
5	1/2-20	7.94 (0.313)	42 (31)	25 (18.4)	26 (19.2)	15.5 (11.4)
6	9/16-18	9.52 (0.375)	47 (34.7)	28 (20.7)	32 (23.6)	19 (14)
8	3/4-16	12.7 (0.500)	89 (65.6)	53 (39.1)	53 (39.1)	32 (23.6)
10	7/8-14	15.88 (0.625)	121 (89.2)	73 (53.8)	63 (46.5)	38 (28)
12	1-1/16-12	19.05 (0.750)	178 (131.3)	107 (78.9)	100 (73.8)	60 (44.3)
14	1-3/16-12	22.22 (0.875)	225 (166)	135 (99.6)	131 (96.6)	79 (58.3)
16	1-5/16-12	25.4 (1.000)	285 (210.2)	170 (125.4)	156 (115.1)	94 (69.3)
20	1-5/8-12	31.75 (1.250)	300 (221.3)	180 (132.8)	210 (154.9)	126 (92.9)
24	1-7/8-12	38.1 (1.500)	388 (286.2)	233 (171.9)	220 (162.3)	132 (97.4)
32	2-1/2-12	50.8 (2.000)	388 (286.2)	233 (171.9)	315 (232.3)	189 (139.4)

* S-Series connectors are used with O-Ring Face Seals (ORFS).

** L-Series connectors are used with 37° flare.

INTRODUCTION

Torque values for inch O-Ring Boss (ORB) port plugs

SAE dash size	UN/UNF thread size	Ferrous		Non-Ferrous
		Internal hex N·m (lb ft) ± 10%	External hex N·m (lb ft) ± 10%	N·m (lb ft) ± 10%
2	5/16-24	7.5 (5.5)	12.5 (9.2)	7.5 (5.5)
3	3/8-24	14.5 (10.7)	21 (15.5)	12.5 (9.2)
4	7/16-20	21 (15.5)	37 (27.3)	22 (16.2)
5	1/2-20	28 (20.7)	42 (31)	25 (18.4)
6	9/16-18	47 (34.7)	47 (34.7)	28 (20.7)
8	3/4-16	89 (65.6)	89 (65.6)	53 (39.1)
10	7/8-14	116 (85.6)	116 (85.6)	70 (51.6)
12	1-1/16-12	176 (129.8)	176 (129.8)	106 (78.2)
14	1-3/16-12	247 (182.2)	247 (182.2)	148 (109.2)
16	1-5/16-12	284 (209.5)	284 (209.5)	170 (125.4)
20	1-5/8-12	357 (263.3)	357 (263.3)	214 (157.8)
24	1-7/8-12	441 (325.3)	441 (325.3)	265 (195.5)
32	2-1/2-12	536 (395.3)	536 (395.3)	322 (237.5)

Torque values for four-bolt flange connections (Metric Screws, Class 10.9)

Metric size mm	Imperial size in	Screw code 61	Code 61 N·m (lb ft) ± 10%	Screw code 62	Code 62 N·m (lb ft) ± 10%
13	1/2	M8 x 1.25	34 (25.1)	M8 x 1.25	34 (25.1)
19	3/4	M10 x 1.5	74 (54.6)	M10 x 1.5	74 (54.6)
25	1	M10 x 1.5	74 (54.6)	M12 x 1.75	137 (101)
32	1-1/4	M10 x 1.5	74 (54.6)	M12 x 1.75	137 (101)
				M14 x 1.5	189 (139.4)
38	1-1/2	M12 x 1.75	137 (101)	M16 x 2	310 (228.6)
51	2	M12 x 1.75	137 (101)	M20 x 2.5	575 (424.1)
64	2-1/2	M12 x 1.75	137 (101)	M24 x 3	575 (424.1)
76	3	M16 x 2	310 (228.6)	M30 x 3.5	680 (501.5)
89	3-1/2	M16 x 2	310 (228.6)	–	–
102	4	M16 x 2	310 (228.6)	–	–
127	5	M16 x 2	310 (228.6)	–	–

Torque values for four-bolt flange connections (Metric Screws, Class 8.8)

Metric size mm	Imperial size in	Screw code 61	Code 61 N·m (lb ft) ± 10%	Screw code 62	Code 62 N·m (lb ft) ± 10%
13	1/2	M8 x 1.25	29 (21.4)	M8 x 1.25	29 (21.4)
19	3/4	M10 x 1.5	57(42)	M10 x 1.5	57(42)
25	1	M10 x 1.5	57(42)	M12 x 1.75	100 (73.8)
32	1-1/4	M10 x 1.5	57(42)	M12 x 1.75	100 (73.8)
				M14 x 1.5	160 (118)
38	1-1/2	M12 x 1.75	100 (73.8)	M16 x 2	250 (184.4)
51	2	M12 x 1.75	100 (73.8)	M20 x 2.5	500 (368.8)
64	2-1/2	M12 x 1.75	100 (73.8)	M24 x 3	575 (424.1)
76	3	M16 x 2	250 (184.4)	M30 x 3.5	680 (501.5)
89	3-1/2	M16 x 2	250 (184.4)	–	–
102	4	M16 x 2	250 (184.4)	–	–
127	5	M16 x 2	250 (184.4)	–	–

INTRODUCTION

Torque values for four-bolt flange connections (Inch Screws, Grade 8)

Metric size mm	Imperial size in	Screw code 61	Code 61 N·m (lb ft) ± 10%	Screw code 62	Code 62 N·m (lb ft) ± 10%
13	1/2	5/16-18	34 (25.1)	5/16-18	34 (25.1)
19	3/4	3/8-16	63 (46.5)	3/8-16	63 (46.5)
25	1	3/8-16	63 (46.5)	7/16-14	97 (71.5)
32	1-1/4	7/16-14	97 (71.5)	1/2-13	158 (116.5)
38	1-1/2	1/2-13	158 (116.5)	5/8-11	310 (228.6)
51	2	1/2-13	158 (116.5)	3/4-10	473 (348.9)
64	2-1/2	1/2-13	158 (116.5)	–	–
76	3	5/8-11	310 (228.6)	–	–
89	3-1/2	5/8-11	310 (228.6)	–	–
102	4	5/8-11	310 (228.6)	–	–
127	5	5/8-11	310 (228.6)	–	–

Tapered thread connection tightening

British Standard Pipe Taper (BSPT) thread size (inch)	National Pipe Thread Fuel (NPTF) thread size (inch)	Turns from finger tight
1/8-28	1/8-27	2 - 3
1/4-19	1/4-18	2 - 3
3/8-19	3/8-18	2 - 3
1/2-14	1/2-14	2 - 3
3/4-14	3/4-14	2 - 3
1-11	1-11 1/2	1.5 - 2.5
1-1/4-11	1-1/4-11 1/2	1.5 - 2.5
1-1/2-11	1-1/2-11 1/2	1.5 - 2.5
2-11	2-11 1/2	1.5 - 2.5

Torque values for banjo bolt connections (Copper washer style)

Bolt thread (metric)	Hex size (mm)	Torque N·m (lb ft) ± 10%
M8 x 1.25	13	13 (9.6)
M10 x 1.25	17	16 (11.8)
M12 x 1.5	17	40 (29.5)
M14 x 1.5	19	45 (33.2)
M16 x 1.5	22	48 (35.4)
M18 x 1.5	24	50 (36.9)
M20 x 1.5	27	73 (53.8)
M22 x 1.5	32	73 (53.8)
M24 x 1.5	32	73 (53.8)

INTRODUCTION

Torque values for O-Ring Face Seals (ORFS) connections

SAE dash size	UN/UNF thread size	Inch tube OD (mm)	Metric tube OD (mm)	Hex size (mm) (Reference only)	* Swivel nut torque N·m (lb ft) ± 10%	** Swivel nut torque N·m (lb ft) ± 10%
4	9/16-18	6.35	6	17	27 (19.9)	27 (19.9)
5	5/8-18	7.94	8	19	34 (25.1)	34 (25.1)
6	11/16-16	9.52	10	22	44 (32.5)	44 (32.5)
8	13/16-16	12.7	12	24	65 (47.9)	65 (47.9)
10	1-14	15.88	16	30	100 (73.8)	100 (73.8)
12	1-3/16-12	19.05	20	36	150 (110.6)	131 (96.6)
14	1-5/16-12	22.23	22	41	163 (120.2)	131 (96.6)
16	1-7/16-12	25.4	25	41	210 (154.9) ***	131 (96.9)
20	1-11/16-12	31.75	30	50	280 (206.5) ***	178 (131.3)
24	2-12	38.1	38	60	375 (276.6) ***	210 (154.9)

* High/Medium-pressure applications > 50 bar (725 psi).

** Low-pressure applications < 50 bar (725 psi).

*** It is recommended to use a four-bolt flange connection instead of O-Ring Face Seals (ORFS) sizes "16" and up.

Torque values for 37° flare connections - Joint Industry Council (JIC)

SAE dash size	UN/UNF thread size	Metric tube OD (mm)	Inch tube OD (mm)	Swivel nut torque N·m (lb ft) ± 10%
2	5/16-24	—	3.18	8.25 (6.1)
3	3/8-24	—	4.76	11.5 (8.5)
4	7/16-20	6	6.35	15.5 (11.4)
5	1/2-20	8	7.94	20 (14.8)
6	9/16-18	10	9.52	25 (18.4)
8	3/4-16	12	12.7	52 (38.4)
10	7/8-14	16	15.88	81 (59.7)
12	1-1/16-12	20	19.05	112 (82.6)
14	1-3/16-12	—	22.22	133 (98.1)
16	1-5/16-12	25	25.4	155 (114.3)
20	1-5/8-12	30/32	31.75	180 (132.8)
24	1-7/8-12	38	38.1	225 (166)
32	2-1/2-12	50	50.8	348 (256.7)

Torque values for 30° flare, 60° cone connections

Nominal size (mm)	British Standard Pipe Parallel (BSPP) thread size	Hex size (mm)	Swivel nut torque N·m (lb ft) ± 10%
5, 6, 6.3	G 1/4	17	25 (18.4)
8, 9, 10	G 3/8	19	34 (25.1)
12, 12.5	G 1/2	22	64 (47.2)
15, 16, 19	G 3/4	30	132 (97.4)
25	G 1	36	196 (144.6)
31.5, 32	G 1-1/4	46	225 (166)
38	G 1-1/2	50	255 (188.1)
50, 51	G 2	65	316 (223.1)

Capacities

Fuel tank	630.0 L (166.4 US gal)
DEF/AdBLUE® tank	96.0 L (25.4 US gal)
Cooling system	21.0 L (5.5 US gal)
Engine (including filter)	19.0 L (5.0 US gal)
Transmission, Rear axle, Hydraulics, Front Power Take-Off (PTO)	148.0 L (39.1 US gal)
Four-Wheel Drive (4WD) – Front axle differential	17.0 L (4.5 US gal)
Four-Wheel Drive (4WD) – Front hubs (Less brakes)	4.5 L (1.19 US gal)
Four-Wheel Drive (4WD) – Front hubs (With brakes)	5.7 L (1.51 US gal)

<https://caseih.servicemanual.com>