

<http://caseih.servicemanual.com>

Magnum™ 180 PST
Magnum™ 200 PST
Magnum™ 220 PST
Powershift Transmission (PST)
Tractor
PIN ZFRH05001 and above

SERVICE MANUAL

Part number 48015888
1st edition English
July 2016





SERVICE MANUAL

Magnum™ 180 PST TIER 4B [ZFRH05001 -]

Magnum™ 200 PST TIER 4B [ZFRH05001 -]

Magnum™ 220 PST TIER 4B [ZFRH05001 -]

<https://caseih.servicemanual.com>

Link Product / Engine

Product	Market Product	Engine
Magnum™ 180 PST TIER 4B [ZFRH05001 -]	Australia New Zealand	F4HFE613K*B002
Magnum™ 180 PST TIER 4B [ZFRH05001 -]	North America	F4HFE613K*B002
Magnum™ 200 PST TIER 4B [ZFRH05001 -]	Australia New Zealand	F4HFE613J*B005
Magnum™ 200 PST TIER 4B [ZFRH05001 -]	North America	F4HFE613J*B005
Magnum™ 220 PST TIER 4B [ZFRH05001 -]	North America	F4HFE613H*B003
Magnum™ 220 PST TIER 4B [ZFRH05001 -]	Australia New Zealand	F4HFE613H*B003

<https://caseih.servicemanual.com>

Contents

INTRODUCTION

Engine.....	10
[10.001] Engine and crankcase	10.1
[10.216] Fuel tanks	10.2
[10.218] Fuel injection system.....	10.3
[10.202] Air cleaners and lines	10.4
[10.500] Selective Catalytic Reduction (SCR) exhaust treatment.....	10.5
[10.400] Engine cooling system	10.6
[10.414] Fan and drive	10.7
[10.310] Aftercooler.....	10.8
[10.304] Engine lubrication system.....	10.9
Power coupling.....	19
[19.100] Drive shaft.....	19.1
[19.110] Flywheel damper	19.2
Transmission.....	21
[21.113] Powershift transmission	21.1
[21.135] Powershift transmission external controls.....	21.2
[21.155] Powershift transmission internal components.....	21.3
[21.160] Creeper	21.4
[21.166] Overdrive.....	21.5
[21.200] Dropbox	21.6
Four-Wheel Drive (4WD) system	23
[23.202] Electro-hydraulic control	23.1
[23.314] Drive shaft.....	23.2
Front axle system	25
[25.100] Powered front axle	25.1

[25.102] Front bevel gear set and differential	25.2
[25.108] Final drive hub, steering knuckles, and shafts	25.3
[25.122] Axle suspension control.....	25.4
Rear axle system.....	27
[27.100] Powered rear axle.....	27.1
[27.106] Rear bevel gear set and differential	27.2
Power Take-Off (PTO).....	31
[31.104] Rear electro-hydraulic control.....	31.1
[31.114] Two-speed rear Power Take-Off (PTO)	31.2
Brakes and controls	33
[33.202] Hydraulic service brakes	33.1
[33.110] Parking brake or parking lock	33.2
[33.220] Trailer brake hydraulic control.....	33.3
Hydraulic systems.....	35
[35.000] Hydraulic systems.....	35.1
[35.102] Pump control valves.....	35.2
[35.104] Fixed displacement pump.....	35.3
[35.105] Charge pump.....	35.4
[35.106] Variable displacement pump	35.5
[35.114] Three-point hitch control valve	35.6
[35.116] Three-point hitch cylinder	35.7
[35.204] Remote control valves	35.8
[35.300] Reservoir, cooler, and filters.....	35.9
Hitches, drawbars, and implement couplings.....	37
[37.110] Rear three-point hitch	37.1
Frames and ballasting	39
[39.140] Ballasts and supports	39.1
Steering.....	41

[41.101] Steering control	41.1
[41.200] Hydraulic control components.....	41.2
[41.206] Pump	41.3
[41.432] Autoguidance steering	41.4
Wheels	44
[44.520] Rear wheels	44.1
Cab climate control	50
[50.100] Heating	50.1
[50.200] Air conditioning.....	50.2
[50.300] Cab pressurizing system	50.3
Electrical systems	55
[55.010] Fuel injection system.....	55.1
[55.011] Fuel tank system	55.2
[55.014] Engine intake and exhaust system.....	55.3
[55.024] Transmission control system	55.4
[55.031] Parking brake electrical system.....	55.5
[55.045] Front axle control system.....	55.6
[55.046] Rear axle control system.....	55.7
[55.047] Steering control system	55.8
[55.050] Heating, Ventilation, and Air-Conditioning (HVAC) control system.....	55.9
[55.051] Cab Heating, Ventilation, and Air-Conditioning (HVAC) controls.....	55.10
[55.100] Harnesses and connectors.....	55.11
[55.130] Rear three-point hitch electronic control system	55.12
[55.201] Engine starting system	55.13
[55.301] Alternator	55.14
[55.302] Battery.....	55.15
[55.408] Warning indicators, alarms, and instruments	55.16
[55.512] Cab controls.....	55.17

[55.518] Wiper and washer system.....	55.18
[55.640] Electronic modules.....	55.19
[55.988] Selective Catalytic Reduction (SCR) electrical system	55.20
[55.DTC] FAULT CODES.....	55.21
Platform, cab, bodywork, and decals.....	90
[90.100] Engine hood and panels	90.1
[90.102] Engine shields, hood latches, and trims	90.2
[90.124] Pneumatically-adjusted operator seat.....	90.3
[90.150] Cab.....	90.4
[90.151] Cab interior.....	90.5
[90.160] Cab interior trim and panels.....	90.6

<https://caseihservicemanual.com>



INTRODUCTION

<https://caseih.servicemanual.com>

Contents

INTRODUCTION

Safety rules	3
Safety rules - General maintenance safety	4
Safety rules - Personal Protective Equipment (PPE)	5
Safety rules - Do Not Operate tag	6
Safety rules - Ecology and the environment	7
Torque - Minimum tightening torques for normal assembly	8
Capacities	13
Product identification	14

<https://caseihservicemanual.com>

Safety rules

Personal safety





This is the safety alert symbol. It is used to alert you to potential personal injury hazards. Obey all safety messages that follow this symbol to avoid possible death or injury.

Throughout this manual and on machine decals, you will find the signal words DANGER, WARNING, and CAUTION followed by special instructions. These precautions are intended for the personal safety of you and those working with you.

Read and understand all the safety messages in this manual before you operate or service the machine.

 **DANGER** indicates a hazardous situation which, if not avoided, will result in death or serious injury. The color associated with DANGER is RED.

 **WARNING** indicates a hazardous situation which, if not avoided, could result in death or serious injury. The color associated with WARNING is ORANGE.

 **CAUTION**, used with the safety alert symbol, indicates a hazardous situation which, if not avoided, could result in minor or moderate injury. The color associated with CAUTION is YELLOW.

FAILURE TO FOLLOW DANGER, WARNING, AND CAUTION MESSAGES COULD RESULT IN DEATH OR SERIOUS INJURY.

Machine safety

NOTICE: Notice indicates a situation which, if not avoided, could result in machine or property damage. The color associated with Notice is BLUE.

Throughout this manual you will find the signal word Notice followed by special instructions to prevent machine or property damage. The word Notice is used to address practices not related to personal safety.

Information

NOTE: Note indicates additional information which clarifies steps, procedures, or other information in this manual.

Throughout this manual you will find the word Note followed by additional information about a step, procedure, or other information in the manual. The word Note is not intended to address personal safety or property damage.

Safety rules - General maintenance safety

General maintenance safety

Keep the area used for servicing the machine clean and dry. Clean up spilled fluids.

Service the machine on a firm, level surface.

Install guards and shields after you service the machine.

Close all access doors and install all panels after servicing the machine.

Do not attempt to clean, lubricate, clear obstructions, or make adjustments to the machine while it is in motion or while the engine is running.

Always make sure that working area is clear of tools, parts, other persons and pets before you start operating the machine.

Unsupported hydraulic cylinders can lose pressure and drop the equipment, causing a crushing hazard. Do not leave equipment in a raised position while parked or during service, unless the equipment is securely supported.

Jack or lift the machine only at jack or lift points indicated in this manual.

Incorrect towing procedures can cause accidents. When you tow a disabled machine follow the procedure in this manual. Use only rigid tow bars.

Stop the engine, remove the key, and relieve pressure before you connect or disconnect fluid lines.

Stop the engine and remove the key before you connect or disconnect electrical connections.

Scalding can result from incorrect removal of coolant caps. Cooling systems operate under pressure. Hot coolant can spray out if you remove a cap while the system is hot. Allow the system to cool before you remove the cap. When you remove the cap, turn it slowly to allow pressure to escape before you completely remove the cap.

Replace damaged or worn tubes, hoses, electrical wiring, etc.

The engine, transmission, exhaust components, and hydraulic lines may become hot during operation. Take care when you service such components. Allow surfaces to cool before you handle or disconnect hot components. Wear protective equipment when appropriate.

When welding, follow the instructions in the manual. Always disconnect the battery before you weld on the machine. Always wash your hands after you handle battery components.

Safety rules - Personal Protective Equipment (PPE)

Personal Protective Equipment (PPE)

Wear Personal Protective Equipment (PPE) such as hard hat, eye protection, heavy gloves, hearing protection, protective clothing, etc.

<https://caseihservicemanual.com>

Safety rules - Do Not Operate tag

Do Not Operate tag

Before you start servicing the machine, attach a 'Do Not Operate' warning tag to the machine in an area that will be visible.

<https://caseih.servicemanual.com>

Safety rules - Ecology and the environment

Soil, air, and water are vital factors of agriculture and life in general. When legislation does not yet rule the treatment of some of the substances required by advanced technology, sound judgment should govern the use and disposal of products of a chemical and petrochemical nature.

NOTE: *The following are recommendations that may be of assistance:*

- Become acquainted with and ensure that you understand the relative legislation applicable to your country.
- Where no legislation exists, obtain information from suppliers of oils, filters, batteries, fuels, antifreeze, cleaning agents, etc., with regard to their effect on man and nature and how to safely store, use, and dispose of these substances.
- Agricultural consultants will, in many cases, be able to help you as well.

Helpful hints

- Avoid filling tanks using cans or inappropriate pressurized fuel delivery systems that may cause considerable spillage.
- In general, avoid skin contact with all fuels, oils, acids, solvents, etc. Most of them contain substances that may be harmful to your health.
- Modern oils contain additives. Do not burn contaminated fuels and or waste oils in ordinary heating systems.
- Avoid spillage when draining off used engine coolant mixtures, engine, gear box and hydraulic oils, brake fluids, etc. Do not mix drained brake fluids or fuels with lubricants. Store them safely until they can be disposed of in a proper way to comply with local legislation and available resources.
- Modern coolant mixtures, i.e. antifreeze and other additives, should be replaced every two years. They should not be allowed to get into the soil, but should be collected and disposed of properly.
- Do not open the air-conditioning system yourself. It contains gases that should not be released into the atmosphere. Your CASE IH dealer or air conditioning specialist has a special extractor for this purpose and will have to recharge the system properly.
- Repair any leaks or defects in the engine cooling or hydraulic system immediately.
- Do not increase the pressure in a pressurized circuit as this may lead to a component failure.
- Protect hoses during welding as penetrating weld splatter may burn a hole or weaken them, allowing the loss of oils, coolant, etc.

Torque - Minimum tightening torques for normal assembly

METRIC NON-FLANGED HARDWARE

NOM. SIZE	CLASS 8.8 BOLT and CLASS 8 NUT		CLASS 10.9 BOLT and CLASS 10 NUT		LOCKNUT CL.8 W/CL8.8 BOLT	LOCKNUT CL.10 W/CL10.9 BOLT
	UNPLATED	PLATED W/ZnCr	UNPLATED	PLATED W/ZnCr		
M4	2.2 N·m (19 lb in)	2.9 N·m (26 lb in)	3.2 N·m (28 lb in)	4.2 N·m (37 lb in)	2 N·m (18 lb in)	2.9 N·m (26 lb in)
M5	4.5 N·m (40 lb in)	5.9 N·m (52 lb in)	6.4 N·m (57 lb in)	8.5 N·m (75 lb in)	4 N·m (36 lb in)	5.8 N·m (51 lb in)
M6	7.5 N·m (66 lb in)	10 N·m (89 lb in)	11 N·m (96 lb in)	15 N·m (128 lb in)	6.8 N·m (60 lb in)	10 N·m (89 lb in)
M8	18 N·m (163 lb in)	25 N·m (217 lb in)	26 N·m (234 lb in)	35 N·m (311 lb in)	17 N·m (151 lb in)	24 N·m (212 lb in)
M10	37 N·m (27 lb ft)	49 N·m (36 lb ft)	52 N·m (38 lb ft)	70 N·m (51 lb ft)	33 N·m (25 lb ft)	48 N·m (35 lb ft)
M12	64 N·m (47 lb ft)	85 N·m (63 lb ft)	91 N·m (67 lb ft)	121 N·m (90 lb ft)	58 N·m (43 lb ft)	83 N·m (61 lb ft)
M16	158 N·m (116 lb ft)	210 N·m (155 lb ft)	225 N·m (166 lb ft)	301 N·m (222 lb ft)	143 N·m (106 lb ft)	205 N·m (151 lb ft)
M20	319 N·m (235 lb ft)	425 N·m (313 lb ft)	440 N·m (325 lb ft)	587 N·m (433 lb ft)	290 N·m (214 lb ft)	400 N·m (295 lb ft)
M24	551 N·m (410 lb ft)	735 N·m (500 lb ft)	762 N·m (560 lb ft)	1016 N·m (750 lb ft)	501 N·m (370 lb ft)	693 N·m (510 lb ft)

NOTE: M4 through M8 hardware torque specifications are shown in pound-inches. M10 through M24 hardware torque specifications are shown in pound-feet.

METRIC FLANGED HARDWARE

NOM. SIZE	CLASS 8.8 BOLT and CLASS 8 NUT		CLASS 10.9 BOLT and CLASS 10 NUT		LOCKNUT CL.8 W/CL8.8 BOLT	LOCKNUT CL.10 W/CL10.9 BOLT
	UNPLATED	PLATED W/ZnCr	UNPLATED	PLATED W/ZnCr		
M4	2.4 N·m (21 lb in)	3.2 N·m (28 lb in)	3.5 N·m (31 lb in)	4.6 N·m (41 lb in)	2.2 N·m (19 lb in)	3.1 N·m (27 lb in)
M5	4.9 N·m (43 lb in)	6.5 N·m (58 lb in)	7.0 N·m (62 lb in)	9.4 N·m (83 lb in)	4.4 N·m (39 lb in)	6.4 N·m (57 lb in)
M6	8.3 N·m (73 lb in)	11 N·m (96 lb in)	12 N·m (105 lb in)	16 N·m (141 lb in)	7.5 N·m (66 lb in)	11 N·m (96 lb in)
M8	20 N·m (179 lb in)	27 N·m (240 lb in)	29 N·m (257 lb in)	39 N·m (343 lb in)	18 N·m (163 lb in)	27 N·m (240 lb in)
M10	40 N·m (30 lb ft)	54 N·m (40 lb ft)	57 N·m (42 lb ft)	77 N·m (56 lb ft)	37 N·m (27 lb ft)	53 N·m (39 lb ft)
M12	70 N·m (52 lb ft)	93 N·m (69 lb ft)	100 N·m (74 lb ft)	134 N·m (98 lb ft)	63 N·m (47 lb ft)	91 N·m (67 lb ft)
M16	174 N·m (128 lb ft)	231 N·m (171 lb ft)	248 N·m (183 lb ft)	331 N·m (244 lb ft)	158 N·m (116 lb ft)	226 N·m (167 lb ft)
M20	350 N·m (259 lb ft)	467 N·m (345 lb ft)	484 N·m (357 lb ft)	645 N·m (476 lb ft)	318 N·m (235 lb ft)	440 N·m (325 lb ft)
M24	607 N·m (447 lb ft)	809 N·m (597 lb ft)	838 N·m (618 lb ft)	1118 N·m (824 lb ft)	552 N·m (407 lb ft)	

IDENTIFICATION

Metric Hex head and carriage bolts, classes 5.6 and up

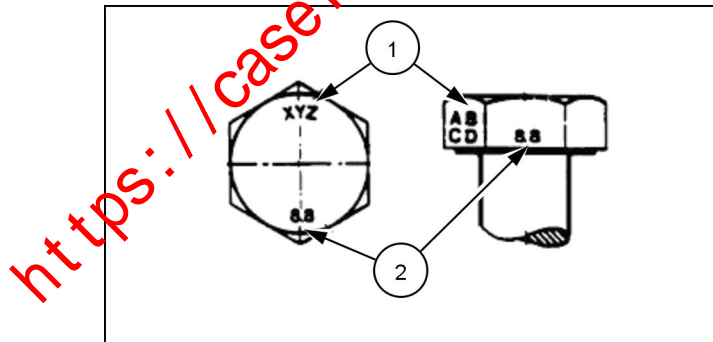

20083680 1

1. Manufacturer's Identification
2. Property Class

Metric Hex nuts and locknuts, classes 05 and up

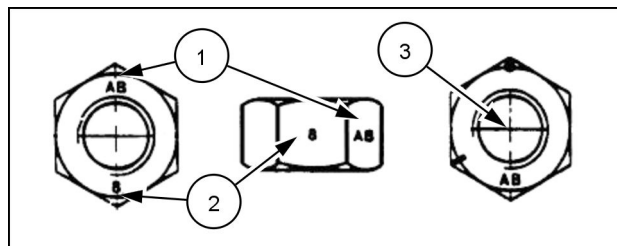

20083681 2

1. Manufacturer's Identification
2. Property Class
3. Clock Marking of Property Class and Manufacturer's Identification (Optional), i.e. marks **60 °** apart indicate Class 10 properties, and marks **120 °** apart indicate Class 8.

INCH NON-FLANGED HARDWARE

NOMINAL SIZE	SAE GRADE 5 BOLT and NUT		SAE GRADE 8 BOLT and NUT		LOCKNUT GrB W/ Gr5 BOLT	LOCKNUT GrC W/ Gr8 BOLT
	UN-PLATED or PLATED SILVER	PLATED W/ZnCr GOLD	UN-PLATED or PLATED SILVER	PLATED W/ZnCr GOLD		
1/4	8 N·m (71 lb in)	11 N·m (97 lb in)	12 N·m (106 lb in)	16 N·m (142 lb in)	8.5 N·m (75 lb in)	12.2 N·m (109 lb in)
5/16	17 N·m (150 lb in)	23 N·m (204 lb in)	24 N·m (212 lb in)	32 N·m (283 lb in)	17.5 N·m (155 lb in)	25 N·m (220 lb in)
3/8	30 N·m (22 lb ft)	40 N·m (30 lb ft)	43 N·m (31 lb ft)	57 N·m (42 lb ft)	31 N·m (23 lb ft)	44 N·m (33 lb ft)
7/16	48 N·m (36 lb ft)	65 N·m (48 lb ft)	68 N·m (50 lb ft)	91 N·m (67 lb ft)	50 N·m (37 lb ft)	71 N·m (53 lb ft)
1/2	74 N·m (54 lb ft)	98 N·m (73 lb ft)	104 N·m (77 lb ft)	139 N·m (103 lb ft)	76 N·m (56 lb ft)	108 N·m (80 lb ft)
9/16	107 N·m (79 lb ft)	142 N·m (105 lb ft)	150 N·m (111 lb ft)	201 N·m (148 lb ft)	111 N·m (82 lb ft)	156 N·m (115 lb ft)
5/8	147 N·m (108 lb ft)	196 N·m (145 lb ft)	208 N·m (153 lb ft)	277 N·m (204 lb ft)	153 N·m (113 lb ft)	215 N·m (159 lb ft)
3/4	261 N·m (193 lb ft)	348 N·m (257 lb ft)	369 N·m (273 lb ft)	491 N·m (362 lb ft)	271 N·m (200 lb ft)	383 N·m (282 lb ft)
7/8	420 N·m (310 lb ft)	561 N·m (413 lb ft)	594 N·m (438 lb ft)	791 N·m (584 lb ft)	437 N·m (323 lb ft)	617 N·m (455 lb ft)
1	630 N·m (465 lb ft)	841 N·m (620 lb ft)	890 N·m (656 lb ft)	1187 N·m (875 lb ft)	654 N·m (483 lb ft)	924 N·m (681 lb ft)

NOTE: For Imperial Units, 1/4 in and 5/16 in hardware torque specifications are shown in pound-inches. 3/8 in through 1 in hardware torque specifications are shown in pound-feet.

INCH FLANGED HARDWARE

NOM- INAL SIZE	SAE GRADE 5 BOLT and NUT		SAE GRADE 8 BOLT and NUT		LOCKNUT GrF W/ Gr5 BOLT	LOCKNUT GrG W/ Gr8 BOLT
	UNPLATED or PLATED SILVER	PLATED W/ZnCr GOLD	UNPLATED or PLATED SILVER	PLATED W/ZnCr GOLD		
1/4	9 N·m (80 lb in)	12 N·m (106 lb in)	13 N·m (115 lb in)	17 N·m (150 lb in)	8 N·m (71 lb in)	12 N·m (106 lb in)
5/16	19 N·m (168 lb in)	25 N·m (221 lb in)	26 N·m (230 lb in)	35 N·m (310 lb in)	17 N·m (150 lb in)	24 N·m (212 lb in)
3/8	33 N·m (25 lb ft)	44 N·m (33 lb ft)	47 N·m (35 lb ft)	63 N·m (46 lb ft)	30 N·m (22 lb ft)	43 N·m (32 lb ft)
7/16	53 N·m (39 lb ft)	71 N·m (52 lb ft)	75 N·m (55 lb ft)	100 N·m (74 lb ft)	48 N·m (35 lb ft)	68 N·m (50 lb ft)
1/2	81 N·m (60 lb ft)	108 N·m (80 lb ft)	115 N·m (85 lb ft)	153 N·m (113 lb ft)	74 N·m (55 lb ft)	104 N·m (77 lb ft)
9/16	117 N·m (86 lb ft)	156 N·m (115 lb ft)	165 N·m (122 lb ft)	221 N·m (163 lb ft)	100 N·m (78 lb ft)	157 N·m (116 lb ft)
5/8	162 N·m (119 lb ft)	216 N·m (159 lb ft)	228 N·m (168 lb ft)	304 N·m (225 lb ft)	147 N·m (108 lb ft)	207 N·m (153 lb ft)
3/4	287 N·m (212 lb ft)	383 N·m (282 lb ft)	405 N·m (299 lb ft)	541 N·m (399 lb ft)	261 N·m (193 lb ft)	369 N·m (272 lb ft)
7/8	462 N·m (341 lb ft)	617 N·m (455 lb ft)	653 N·m (482 lb ft)	871 N·m (642 lb ft)	421 N·m (311 lb ft)	594 N·m (438 lb ft)
1	693 N·m (512 lb ft)	925 N·m (682 lb ft)	979 N·m (722 lb ft)	1305 N·m (963 lb ft)	631 N·m (465 lb ft)	890 N·m (656 lb ft)

IDENTIFICATION

Inch Bolts and free-spinning nuts

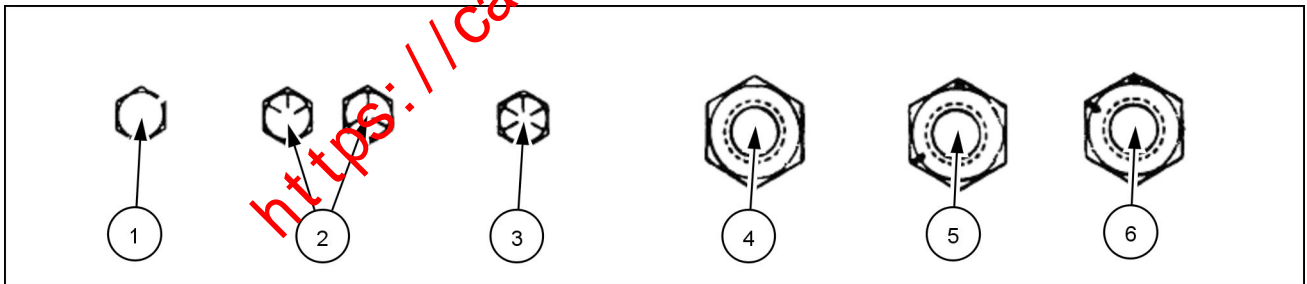

20083682 3

Grade Marking Examples

SAE Grade Identification			
1	Grade 2 - No Marks	4	Grade 2 Nut - No Marks
2	Grade 5 - Three Marks	5	Grade 5 Nut - Marks 120 ° Apart
3	Grade 8 - Five Marks	6	Grade 8 Nut - Marks 60 ° Apart

Inch Lock Nuts, All Metal (Three optional methods)

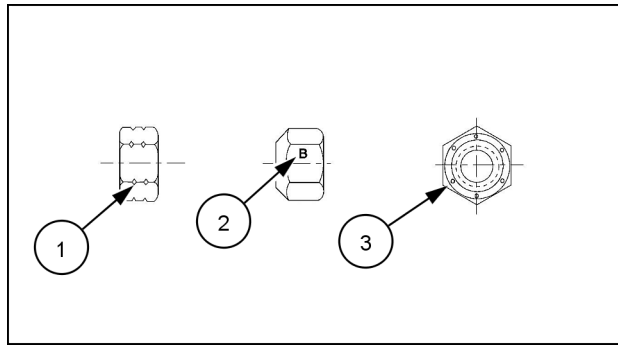

20090268 4

Grade Identification

Grade	Corner Marking Method (1)	Flats Marking Method (2)	Clock Marking Method (3)
Grade A	No Notches	No Mark	No Marks
Grade B	One Circumferential Notch	Letter B	Three Marks
Grade C	Two Circumferential Notches	Letter C	Six Marks

<https://caseihservicemanual.com>

Capacities

Magnum 180, 200, 220 and 240



System	Metric	U.S.	Imperial
Engine Oil — CASE IH AKCELA UNITEK NO. 1™ SBL CJ-4 or CASE IH AKCELA NO. 1™ ENGINE OIL			
No filter change	16 l	4.23 US gal	3.52 UK gal
With filter change	16.5 l	4.36 US gal	3.63 UK gal
Cooling system	23.65 l	6.25 US gal	5.2 UK gal
Transmission/hydraulic system — CASE IH AKCELA HY-TRAN® ULTRACTION			
Full Powershift	85 l	22.5 US gal	18.7 UK gal
Continuous Variable Transmission (CVT)	100 l	26.4 US gal	22.0 UK gal
Mechanical Front Drive (MFD) — TUTELA HYPOIDE EP GEAR LUBE or CASE IH AKCELA GEAR 135 H EP 85W-140			
Case IH 4.0 fixed front axle			
Differential	11 l	11.6 US qt	21.6 UK pt
Planetary (each)	2.3 l	2.4 US qt	2.0 UK qt
Case IH 4.75 saddle suspended front axle			
Differential	17.5 l	18.5 US qt	30.8 UK pt
Planetary (each)	4.3 l	4.5 US qt	7.5 UK qt
Mechanical Front Drive (MFD) gearbox — TUTELA HYPOIDE EP GEAR LUBE SAE 85W-140			
	275 mL	9.3 US fl oz	9.7 UK fl oz
Fuel tank	586.7 l	155 US gal	129 UK gal
DEF/AdBlue® tank	88.2 l	23.1 US gal	19.4 UK gal

<https://caseih.servicemanual.com>

Product identification

Tractor model and Product Identification Number (PIN)

Write your model number, Product Identification Number (PIN) or serial number of major components on the lines provided. If needed, give these numbers to your dealer when you need parts or information for your machine.

 CNH Industrial America LLC Racine, WI 53404 U.S.A. Made In U.S.A.		Year of Construction 3	Model Year 4	 MP04
Type 1	EEC Number 2	Product Identification Number 5		
• Total Permissible Mass (*): 6 kg • Permissible Front Axle Load (*): 7 kg • Permissible Rear Axle Load (*): 8 kg (* Depending on the Tires 9)		Permissible Towable Mass: • Unbraked Towable Mass: 10 kg • Independently-Braked Towable Mass: 11 kg • Inertia-Braked Towable Mass: 12 kg • Towable Mass Fitted with an Assisted Braking System: (Hydraulic or Pneumatic): 13 kg		

RAIL14TR02078EA 1

1. Type	8. Permissible rear axle load (*)
2. EEC number	9. (*) Depending on the tires
3. Year of construction	Permissible towable mass:
4. Model year	• 10. Unbraked towable mass:
5. Product identification number	• 11. Independently braked towable mass:
6. Total permissible mass (*):	• 12. Inertia braked towable mass:
7. Permissible front axle load (*):	• 13. Towable mass fitted with an assisted braking system: (hydraulic or pneumatic)

Model :

PIN

NOTE: Located on right hand front frame casting.

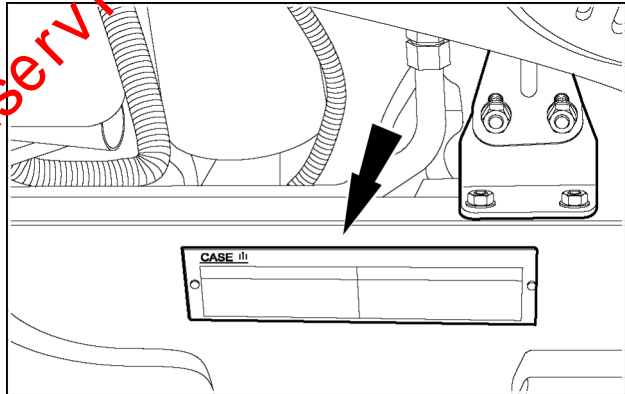

RCPH08CCH625AAB 2

Roll Over Protective Structure (ROPS) serial number

NOTE: Located on the right hand cab floor.

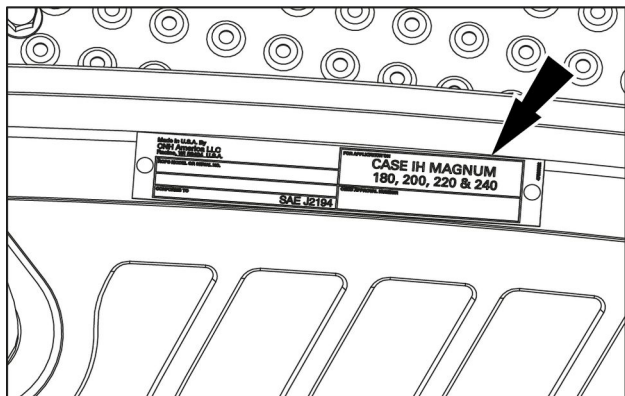

RAIL13TR04461AA 3

Engine serial number

NOTE: Located on the right hand side of the engine on the casting. A serial number decal is also located on the top of the valve cover.

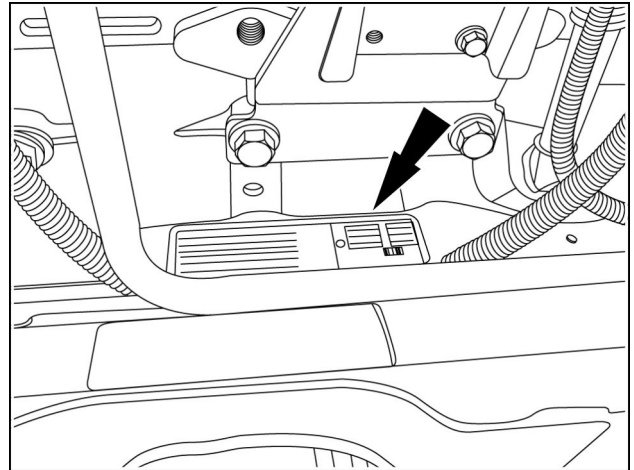

RCPH10CCH009BAA 4

Transmission serial number

NOTE: Located on the right hand side of the Powershift transmission behind and to the left of the battery carrier. Located on the top of the Continuously Variable Transmission (CVT) housing, parallel to the accumulator (shown).

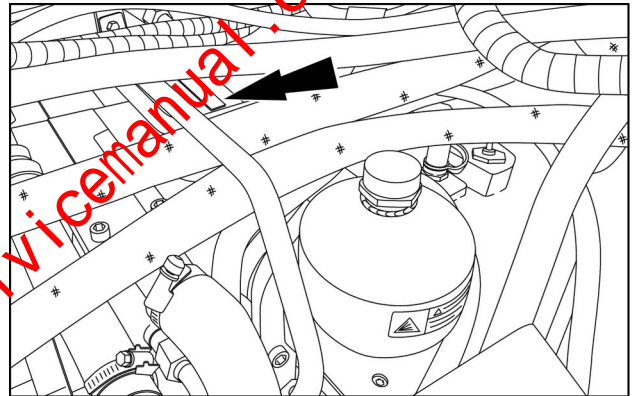

RAIL13TR03691AA 5

Axle serial number

Class 4.0 fixed front axle: Located on the front right hand side of the axle housing (shown).

Class 4.75 saddle suspended front axle: Located on the rear left hand side of the axle housing (not shown).

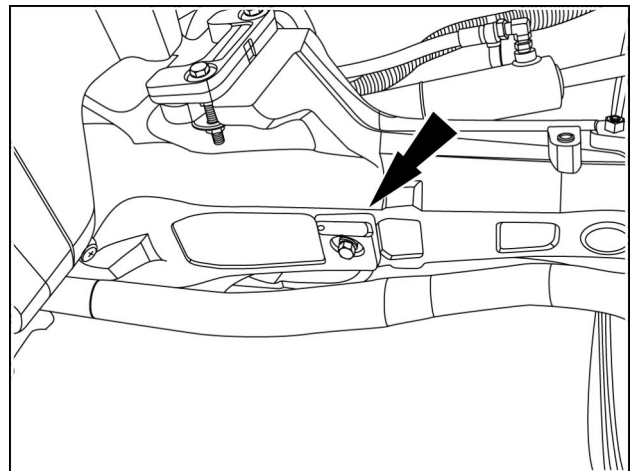

RCPH10CCH010BAA 6

Driveline serial number

Located on the right hand side of the drop box below the exhaust elbow.

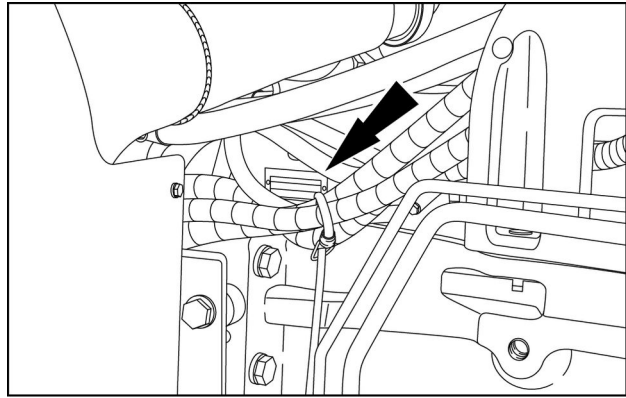

RAIL13TR03700AA 7

<https://caseihservicemanual.com>



SERVICE MANUAL

Engine

Magnum™ 180 PST TIER 4B [ZFRH05001 -]
Magnum™ 200 PST TIER 4B [ZFRH05001 -]
Magnum™ 220 PST TIER 4B [ZFRH05001 -]

<https://caseihservicemanual.com>