

<http://caseihservicemanual.com>

FARMALL® 85C

FARMALL® 95C

FARMALL® 105C

FARMALL® 115C

With Hi-Lo Transmission

With Mechanical or Power Shuttle Transmission

Tractor

With Hi-Lo Transmission PIN ZxJV0xxxx and above

With Mechanical or Power Shuttle Transmission PIN ZxJV5xxxx and above

SERVICE MANUAL

Part number 47840678

English

March 2015

Replaces part number 47561951





SERVICE MANUAL

Farmall® 105C less cab, with hi-lo transmission [ZxJV0xxxx] , Farmall® 105C less cab, with mechanical or power shuttle transmission [ZxJV5xxxx] , Farmall® 105C with cab, with hi-lo transmission [ZxJV0xxxx] , Farmall® 105C with cab, with mechanical or power shuttle transmission [ZxJV5xxxx] , Farmall® 115C less cab, with hi-lo transmission [ZxJV0xxxx] , Farmall® 115C less cab, with mechanical or power shuttle transmission [ZxJV5xxxx] , Farmall® 115C with cab, with hi-lo transmission [ZxJV0xxxx] , Farmall® 115C with cab, with mechanical or power shuttle transmission [ZxJV5xxxx] , Farmall® 85C less cab, with hi-lo transmission [ZxJV0xxxx] , Farmall® 85C less cab, with mechanical or power shuttle transmission [ZxJV5xxxx] , Farmall® 85C with cab, with hi-lo transmission [ZxJV0xxxx] , Farmall® 85C with cab, with mechanical or power shuttle transmission [ZxJV5xxxx] , Farmall® 95C less cab, with hi-lo transmission [ZxJV0xxxx] , Farmall® 95C less cab, with mechanical or power shuttle transmission [ZxJV5xxxx] , Farmall® 95C with cab, with hi-lo transmission [ZxJV0xxxx] , Farmall® 95C with cab, with mechanical or power shuttle transmission [ZxJV5xxxx]

<https://caseihservice.com>

Link Product / Engine

Product	Market Product	Engine
Farmall® 105C less cab, with mechanical or power shuttle transmission [ZxJV5xxxx]	North America	F5DFL413J*A002
Farmall® 105C with cab, with mechanical or power shuttle transmission [ZxJV5xxxx]	North America	F5DFL413J*A002
Farmall® 105C less cab, with hi-lo transmission [ZxJV0xxxx]	North America	F5DFL413A*A001
Farmall® 105C with cab, with hi-lo transmission [ZxJV0xxxx]	North America	F5DFL413A*A001
Farmall® 85C less cab, with mechanical or power shuttle transmission [ZxJV5xxxx]	North America	F5DFL413L*A002
Farmall® 85C with cab, with mechanical or power shuttle transmission [ZxJV5xxxx]	North America	F5DFL413L*A002
Farmall® 85C less cab, with hi-lo transmission [ZxJV0xxxx]	North America	F5DFL413J*A001
Farmall® 85C with cab, with hi-lo transmission [ZxJV0xxxx]	North America	F5DFL413J*A001
Farmall® 95C less cab, with mechanical or power shuttle transmission [ZxJV5xxxx]	North America	F5DFL413K*A002
Farmall® 95C with cab, with mechanical or power shuttle transmission [ZxJV5xxxx]	North America	F5DFL413K*A002
Farmall® 95C less cab, with hi-lo transmission [ZxJV0xxxx]	North America	F5DFL413K*A001
Farmall® 95C with cab, with hi-lo transmission [ZxJV0xxxx]	North America	F5DFL413K*A001

<https://caseinservicemanual.com>

Contents

INTRODUCTION

Engine.....	10
[10.001] Engine and crankcase	10.1
[10.216] Fuel tanks	10.2
[10.501] Exhaust Gas Recirculation (EGR) - Diesel Particulate Filter (DPF) exhaust treatment	10.3
[10.400] Engine cooling system	10.4
[10.414] Fan and drive	10.5
[10.310] Aftercooler.....	10.6
Clutch	18
[18.100] Clutch mechanical release control	18.1
[18.104] Clutch hydraulic release control.....	18.2
[18.110] Clutch and components	18.3
Transmission.....	21
[21.130] Mechanical transmission external controls.....	21.1
[21.112] Power shuttle transmission.....	21.2
[21.110] Master clutch housing	21.3
[21.134] Power shuttle transmission external controls	21.4
[21.154] Power shuttle transmission internal components	21.5
[21.160] Creeper	21.6
[21.162] Reverser	21.7
[21.168] Hi-Lo unit.....	21.8
[21.109] Transmission cooler and lines.....	21.9
[21.118] Transmission/Rear drive	21.10
[21.148] Transmission/Rear drive internal components	21.11
[21.AAA] Transmission generic sub-group	21.12
Four-Wheel Drive (4WD) system	23

[23.101] Mechanical control	23.1
[23.202] Electro-hydraulic control	23.2
[23.314] Drive shaft.....	23.3
Front axle system	25
[25.100] Powered front axle	25.1
[25.102] Front bevel gear set and differential	25.2
[25.108] Final drive hub, steering knuckles, and shafts	25.3
[25.400] Non-powered front axle	25.4
Rear axle system.....	27
[27.106] Rear bevel gear set and differential.....	27.1
[27.120] Planetary and final drives	27.2
[27.100] Powered rear axle.....	27.3
Power Take-Off (PTO).....	31
[31.101] Rear mechanical control	31.1
[31.104] Rear electro-hydraulic control.....	31.2
[31.110] One-speed rear Power Take-Off (PTO)	31.3
[31.114] Two-speed rear Power Take-Off (PTO)	31.4
[31.146] Front Power Take-Off (PTO)	31.5
Brakes and controls	33
[33.202] Hydraulic service brakes	33.1
[33.110] Parking brake or parking lock	33.2
Hydraulic systems.....	35
[35.000] Hydraulic systems.....	35.1
[35.104] Fixed displacement pump	35.2
[35.160] Front hitch controls and lines	35.3
[35.204] Remote control valves	35.4
[35.114] Three-point hitch control valve	35.5
[35.116] Three-point hitch cylinder	35.6

[35.701] Front loader arm hydraulic system	35.7
[35.723] Front loader bucket hydraulic system	35.8
Hitches, drawbars, and implement couplings.....	37
[37.100] Drawbars and towing hitches	37.1
[37.110] Rear three-point hitch	37.2
[37.120] Rear three-point hitch linkage.....	37.3
[37.162] Front hitch.....	37.4
[37.166] Front hitch linkage.....	37.5
Steering.....	41
[41.101] Steering control	41.1
[41.106] Tie rods.....	41.2
[41.200] Hydraulic control components.....	41.3
[41.206] Pump	41.4
[41.216] Cylinders	41.5
Wheels.....	44
[44.511] Front wheels.....	44.1
[44.520] Rear wheels.....	44.2
Cab climate control.....	50
[50.100] Heating.....	50.1
[50.104] Ventilation	50.2
[50.200] Air conditioning.....	50.3
Electrical systems.....	55
[55.100] Harnesses and connectors.....	55.1
[55.201] Engine starting system	55.2
[55.301] Alternator.....	55.3
[55.302] Battery.....	55.4
[55.640] Electronic modules	55.5
[55.048] Rear Power Take-Off (PTO) control system	55.6

[55.408] Warning indicators, alarms, and instruments	55.7
[55.DTC] FAULT CODES.....	55.8
Front loader and bucket.....	82
[82.100] Arm.....	82.1
[82.300] Bucket.....	82.2
[82.AAA] Front loader and bucket generic sub-group	82.3
Platform, cab, bodywork, and decals	90
[90.150] Cab.....	90.1
[90.151] Cab interior.....	90.2
[90.160] Cab interior trim and panels.....	90.3
[90.154] Cab doors and hatches	90.4
[90.110] Operator platform less cab	90.5
[90.100] Engine hood and panels	90.6
[90.102] Engine shields, hood latches, and trims	90.7

<https://caseihservicemanual.com>



INTRODUCTION

<https://caseih.servicemanual.com>

Contents

INTRODUCTION

Advice	3
Note to the Owner WARNINGS FOR AIR CONDITIONING SYSTEM REPAIR OPERATIONS	4
Safety rules SAFETY REGULATIONS	5
Personal safety CAB AIR CONDITIONING SYSTEM	8
Basic instructions	9
Special tools NOTES FOR EQUIPMENT	11
Consumables	12
Part identification	13

<https://caseihservicemanual.com>

Advice

IMPORTANT NOTICE

All maintenance and repair work described in this manual must be performed exclusively by CASE IH service technicians, in strict accordance with the instructions given and using any specific tools necessary. Anyone performing the operations described herein without strictly following the instructions is personally responsible for any eventual injury or damage to property.

<https://caseihservicemanual.com>

Note to the Owner WARNINGS FOR AIR CONDITIONING SYSTEM REPAIR OPERATIONS

Starting the system at low temperatures can damage the compressor. Only operate the air conditioner when the engine is hot and the temperature inside the cab is at least **20 °C (68.00 °F)**.

When disconnecting the hoses, close the ends with plastic caps to prevent foreign matter and humidity from getting inside the hoses.

Handle the thermostatic sensor carefully to avoid damage that may prevent efficient system operation.

Always use two spanners to unscrew the hose fittings to avoid twisting the fitting.

Do not use any type of engine oil to lubricate the compressor and the system.

Never leave the compressor oil container open, always make sure that it is tightly closed. If left exposed the oil will absorb humidity from the air and may, subsequently, damage the system.

Do not transfer compressor oil from the original container to another container.

Do not introduce any additives to the compressor oil. Any additional substances could contain elements which are incompatible with the chemical base of the refrigerant and thus alter its characteristics.

Check that the thermostatic sensor is correctly inserted in the fins on the evaporator to ensure efficient system operation.

<https://caseihservicemanual.com>

Safety rules SAFETY REGULATIONS

TO PREVENT ACCIDENTS

Most accidents or injuries that occur in workshops are the result of non-observance of simple and fundamental safety regulations.

For this reason, IN MOST CASES THESE ACCIDENTS CAN BE AVOIDED: by foreseeing possible causes and consequently acting with the necessary caution and care.

Accidents may occur with all types of vehicle, regardless of how well it was designed and built.

A careful and judicious service technician is the best guarantee against accidents.

Precise observance of the most basic safety rule is normally sufficient to avoid many serious accidents.

DANGER: Never carry out any cleaning, lubrication or maintenance operations when the engine is running.

GENERAL

- Carefully follow specified repair and maintenance procedures.
- Do not wear rings, wristwatches, jewellery, unbuttoned or loose articles of clothing such as: ties, torn clothing, scarves, open jackets or shirts with open zips that may remain entangled in moving parts.
It is advised to wear approved safety clothing, e.g: non-slip footwear, gloves, safety goggles, helmets, etc.
- Do not carry out repair operations with someone sitting in the driver's seat, unless the person is a trained technician who is assisting with the operation in question.
- Operate the vehicle and use the implements exclusively from the driver's seat.
- Do not carry out operations on the vehicle with the engine running, unless specifically indicated.
- Stop the engine and ensure that all pressure is relieved from hydraulic circuits before removing caps, covers, valves, etc.
- All repair and maintenance operations must be carried out using extreme care and attention.
- Service steps and platforms used in a workshop or in the field should be built in compliance with the safety rules in force.
- Disconnect the batteries and label all controls to indicate that the vehicle is being serviced. Block the machine and all equipment which should be raised.
- Do not check or fill fuel tanks, accumulator batteries, nor use starting liquid when smoking or near naked flames, as these fluids are inflammable.
- Brakes are inoperative if manually released for repair or maintenance purposes.
In such cases, the machine should be kept constantly under control using blocks or similar devices.
- The fuel nozzle should always be in contact with the filling aperture. Maintain this position until filling operations are completed in order to avoid possible sparks caused by the accumulation of static electricity.
- Only use specified towing points for towing the tractor, connect parts carefully. Make sure that all pins and/or locks are secured in position before applying traction.
Never remain near the towing bars, cables or chains that are operating under load
- Transport vehicles that cannot be driven using a trailer or a low-loading platform trolley, if available.
- When loading or unloading the vehicle from the trailer (or other means of transport), select a flat area capable of sustaining the trailer or truck wheels, firmly secure the tractor to the truck or trailer and lock the wheels in the position.
- Electric heaters, battery-chargers and similar equipment must only be powered by auxiliary power supplies with efficient ground insulation to avoid electrical shock hazards.
- Always use suitable hoisting or lifting devices when raising or moving heavy parts.
- Take extra care if bystanders are present.
- Never pour gasoline or diesel oil into open, wide and low containers.
- Never use gasoline, diesel oil or other inflammable liquids as cleaning agents. Use non-flammable non-toxic proprietary solvents.
- Wear safety goggles with side guards when cleaning parts with compressed air.
- Limit the air pressure to a maximum of **2.1 bar (30.5 psi)**, according to local regulations.

INTRODUCTION

- Do not run the engine in confined spaces without suitable ventilation.
- Do not smoke, use naked flames, or cause sparks in the area when fuel filling or handling highly inflammable liquids.
- Never use naked flames for lighting when working on the machine or checking for leaks.
- All movements must be carried out carefully when working under, on or near the vehicle and wear protective equipment: helmets, goggles and special footwear.
- When carrying out checks with the engine running, request the assistance of an operator in the driver's seat. The operator must maintain visual contact with the service technician at all times.
- If operating outside the workshop, position the vehicle on a flat surface and lock in position. If working on a slope, lock the vehicle in position and move to a flat area as soon as is safely possible.
- Damaged or bent chains or cables are unreliable. Do not use them for lifting or towing. Always use suitable protective gloves when handling chains or cables.
- Chains should always be safely secured. Ensure that fastening device is strong enough to hold the load foreseen. No persons should stop near the fastening point, trailing chains or cables.
- Maintenance and repair operations must be carried out in a CLEAN and DRY area, eliminate any water or oil spillage immediately.
- Do not create piles of oil or grease--soaked rags as they represent a serious fire hazard, store them in a closed metal container.
Before starting the vehicle or implements, make sure that the driver's seat is locked in position and always check that the area is free of persons or obstacles.
- Empty pockets of all objects that may fall unobserved into the vehicle parts when disassembled.
- In the presence of protruding metal parts, use protective goggles or goggles with side guards, helmets, special footwear and gloves.
- Handle all parts carefully, do not put your hands or fingers between moving parts, wear suitable safety clothing -- safety goggles, gloves and shoes.

WELDING OPERATIONS

- When welding, use protective safety devices: tinted safety goggles, helmets, special overalls, gloves and footwear. All persons present in the area where welding is taking place must wear tinted goggles. NEVER LOOK AT THE WELDING ARC IF YOUR EYES ARE NOT SUITABLY PROTECTED.
- Where possible, remove the part or tool that requires arc welding from the tractor.
- Disconnect both battery leads. Isolate the cable ends to avoid contact with each other and the tractor.
- Position the welder ground clamp as near as possible to the area where welding is taking place.
- Remove the electronic control units located on the tractor if welding is to be carried out near these control units.
- Never allow welding cables to lay on, near or across any electrical wiring or electronic component while welding is in progress.
- Metal cables tend to fray with repeated use. Always use suitable protective devices (gloves, goggles, etc.) when handling cables.

START UP

- Never start the engine in confined spaces that are not equipped with adequate ventilation for exhaust gas extraction.
- Never place the head, body, limbs, feet, hands or fingers near fans or rotating belts.

ENGINE

- Always loosen the radiator cap slowly before removing it to allow any remaining pressure in the system to be discharged. Coolant should be topped up only when the engine is stopped or idle if hot.
- Never fill up with fuel when the engine is running, especially if hot, in order to prevent the outbreak of fire as a result of fuel spillage
- Never check or adjust fan belt tension when the engine is running.
Never adjust the fuel injection pump when the vehicle is moving.

- Never lubricate the vehicle when the engine is running.

ELECTRICAL SYSTEMS

- If it is necessary to use auxiliary batteries, remember that both ends of the cables must be connected as follows: (+) with (+) and (-) with (-).
- Avoid short-circuiting the terminals. GAS RELEASED FROM BATTERIES IS HIGHLY INFLAMMABLE.
- During charging, leave the battery compartment uncovered to improve ventilation.
- Never check the battery charge using "jumpers" (metal objects placed on the terminals).
- Avoid sparks or flames near the battery zone to prevent explosion hazards.
- Before servicing operations, check for fuel or current leaks. Eliminate any eventual leaks before starting work.
- Never charge batteries in confined spaces. Make sure that there is adequate ventilation in order to prevent accidental explosion hazards as a result of the accumulation of gases released during charging operations.
- Always disconnect the battery before performing any kind of servicing on the electrical system.

HYDRAULIC SYSTEMS

- Some fluid slowly coming out from a very small port can be almost invisible and be strong enough to penetrate the skin. Check for leaks using a piece of cardboard, NEVER USE HANDS.
- If any liquid penetrates skin tissue, call for medical aid immediately
- Serious skin infections may result if medical attention is not given.
- Use the specific tools when checking pressure values on the hydraulic system.

WHEELS AND TYRES

- Check that the tyres are correctly inflated at the pressure specified by the manufacturer. Periodically check possible damages to the rims and tyres.
- Stand away from (at the side of) the tire when checking inflation pressure.
- Only check pressure when the vehicle is unloaded and the tires are cold, to avoid incorrect readings as a result of over--pressure.
- Do not re--use parts of recovered wheels as incorrect welding or brazing may heat the material, causing it to weaken and eventually damage or break the wheel.
- Never cut, nor weld a rim with the inflated tyre assembled.
- When removing the wheels, lock both the front and rear vehicle wheels.
- Always position support stands when raising the vehicle, in order to conform to current safety regulations.
- Deflate the tyre before removing any object caught into the tyre tread.
- Never inflate tires using inflammable gases; this could cause an explosion and put operator safety at risk.

REMOVAL AND RE-FITTING

- Lift and handle all heavy parts using suitable lifting equipment and make sure that all slings and hooks are correctly secured.
- Handle all parts carefully during lifting operations, keep an eye on the personnel working near the load to be lifted. Never insert hands or fingers between parts, always wear approved accident prevention clothing (goggles, gloves and work boots).
- Avoid twisting chains or metal cables and always wear safety gloves when handling cables or chains.

Personal safety CAB AIR CONDITIONING SYSTEM

SAFETY REGULATIONS

- The refrigerant must be handled with great care in order to avoid personal injury; always use safety goggles and gloves.
- Liquid refrigerant can cause freezing of the skin and serious damage to the eyes, sometimes resulting in permanent blindness.
- Keep the refrigerant container away from heat sources. Heat will cause an increase in pressure of the refrigerant and could cause the container to explode.
- If refrigerant comes into contact with a naked flame or a hot metal surface it produces a toxic gas, which is dangerous if inhaled.
- In order to avoid accidents follow the simple precautions described below.
- The operation of emptying and charging the system must be carried out in a well-ventilated area, well away from any naked flames.
- During the charging and emptying operations, take the necessary precautions to protect the face and above all the eyes from accidental contact with refrigerant.
- In the event of an accident, proceed as follows:
 - if refrigerant splashes into the eyes, wash immediately with a few drops of mineral oil, then wash them thoroughly with a solution of boric acid and water (one spoonful of acid in 1/4 cup of water) and seek medical assistance immediately.
 - freezing of the skin caused by contact with liquid refrigerant may be treated by gradually warming the injured area with cold water, followed by the application of a greasy cream. Request medical assistance.
 - the air conditioning system contains a mixture of refrigerant and oil under high pressure; under no circumstances loosen pipe fittings/unions or work on the pipes without having first drained the system.
 - do not loosen or remove the compressor oil level check cap with the system pressurized.
 - do not heat the refrigerant container. If the temperature exceeds **50 °C (122.00 °F)** the pressure will increase very rapidly.
 - keep the air conditioning system away from heat sources to prevent explosions as a result of an increase in pressure in the system piping.
- When transferring refrigerant from one container to another, only use homologated liquid refrigerant containers equipped with safety valves.
- Never fill liquid refrigerant containers over **80 % (80.0 %)** of their maximum capacity.
- Do not modify the settings of safety valves and the control devices.
- Never connect the recovery/recycling and evacuation/charging stations to electrical power outlets with voltages other than those specified; do not leave the stations powered up unless they are to be used immediately.

Basic instructions

IGN.

Before commencing any work on the vehicle, always disconnect and isolate the negative lead from the battery, unless otherwise indicated for a specific operation (for example: an operation to be carried out with the engine running), on completion of which the negative lead should be disconnected before proceeding with the work.

SHIMMING

At each adjustment, select the shims measuring them one at a time with a micrometer and summing the values obtained: do not measure the complete pack of shims all together or rely on the nominal values indicated on the shims as these could produce incorrect measurements.

ROTATING SHAFT SEALS

For correct rotating shaft seal installation, proceed as follows:

- before assembly, allow the seal to soak in the oil it will be sealing for at least thirty minutes;
- thoroughly clean the shaft and check that the working surface on the shaft is not damaged;
- position the sealing lip facing the fluid; with hydrodynamic lips, take into consideration the shaft rotation direction and position the grooves so that they will deviate the fluid towards the inner side of the seal;
- coat the sealing lip with a thin layer of lubricant (use oil rather than grease) and fill the gap between the sealing lip and the dust lip on double lip seals with grease;
- insert the seal in its seat and press down using a flat punch; do not tap the seal with a hammer or mallet;
- whilst inserting the seal, check that it is perpendicular to the seat; once settled, make sure that it makes contact with the thrust element, if required;
- to prevent damaging the seal lip on the shaft, position a protective guard during installation operations.

O-RING SEALS

Lubricate the O-RING seals before inserting them in the seats, this will prevent them from overturning and twisting, which would jeopardise sealing efficiency.

SEALERS

Apply one of the following sealing compounds on the mating surfaces marked with an X: **LOCTITE® 518™** or **LOCTITE® 5205**.

Before applying the compound, prepare the surfaces in the following manner:

- remove any incrustations using a wire brush;
- thoroughly de-grease the surfaces using one of the following cleaning agents: trichlorethylene, petrol or a water and soda solution.

BEARINGS

When installing bearings it is advised to:

- heat the bearings to 80 ÷ 90 °C before fitting on the shafts;
- allow the bearings to cool before installing them.

ROLL PINS

When fitting split socket elastic pins, ensure that the pin notch is positioned in the direction of the force required to stress the pin.

Spiral roll pins, on the other hand, can be fitted with any orientation.

NOTICES

Wear limit values indicated for certain parts are recommended, but not binding. The terms “front”, “rear”, “right-hand” and “left-hand” (when referred to different parts) are intended as seen from the driving position with the tractor in the normal direction of movement.

MOVING THE TRACTOR WITH THE BATTERY REMOVED

External power supply cables should only be connected to the respective positive and negative cable terminals, using efficient clamps that guarantee adequate and secure contact. Disconnect all services (lights, windshield wipers, etc.) before starting the vehicle. If the vehicle electrical system requires checking, carry out operations with the power supply connected; Once checking is completed, disconnect all services and switch off the power supply before disconnecting the cables.

<https://caseihservicemanual.com>

Special tools NOTES FOR EQUIPMENT

The tools that CASE IH propose and illustrate in this manual are:

- specifically researched and designed for use with CASE IH vehicles;
- necessary to make reliable repair;
- accurately built and strictly tested to offer efficient and long--lasting working means.

By using these tools, repair personnel will benefit from:

- operating in optimal technical conditions;
- obtaining the best results;
- saving time and effort;
- working in safe conditions.

<https://caseihservicemanual.com>

Consumables

	QUANTITY	RECOMMENDED CASE IH PRODUCTS	SPECIFICATION CASE IH	INTERNATIONAL SPECIFICATION
Cooling system	16 l (4.2 US gal) Model without cab 14 l (3.7 US gal)	Water and CASE IH AKCELA PREMIUM ANTI-FREEZE fluid 50 % + 50 %	MS1710	-
Windshield washer reservoir	2 l (0.5 US gal)	Water and detergent liquid	-	-
Fuel tank	115 l (30 US gal)	Decanted, filtered diesel fuel	-	-
Engine oil	8.5 l (2 US gal)	CASE IH AKCELA UNITEK NO. 1™ SBL CJ-4 SAE 10W-40	MAT3521	API CJ-4 ACEA E7/E9
Brake control circuit	0.7 l (0.18 US gal)	CASE IH AKCELA LHM FLUID		ISO 7308
Front axle	4.5 l (1.2 US gal)	CASE IH AKCELA NEXPLORE™ FLUID	MAT3525	API GL4 ISO 32/46 SAE 10W-30
Final drives (each)	1.0 l (0.3 US gal)			
Transmission/rear axle				
Mechanical	48 l (12.7 US gal)			
Hydraulic	58 l (15.3 US gal)			
Front wheel hubs Grease fittings		CASE IH AKCELA 251H EP MULTI-PURPOSE GREASE		NLGI 2
Air-conditioning refrigerant	650 g (23 oz)	-	-	R134
Air-conditioning compressor oil	0.185 l (0.05 US gal)		-	SP10

<https://caseih.servicemanual.com>

Part identification

Use solely genuine parts, which guarantee the same quality, duration and safety as the original parts as they are identical to the ones fitted during production.
Only genuine parts can offer this guarantee.

When ordering spare parts, always provide the following information:

- tractor model (commercial name) and frame number;
- engine type and number;
- part number of the ordered part, which can be found in the “Microfiches” or the “Spare Parts Catalogue”, used for order processing.

<https://caseihservicemanual.com>

<https://caseihservicemanual.com>



SERVICE MANUAL

Engine

Farmall® 105C less cab, with hi-lo transmission [ZxJV0xxxx] , Farmall® 105C less cab, with mechanical or power shuttle transmission [ZxJV5xxxx] , Farmall® 105C with cab, with hi-lo transmission [ZxJV0xxxx] , Farmall® 105C with cab, with mechanical or power shuttle transmission [ZxJV5xxxx] , Farmall® 115C less cab, with hi-lo transmission [ZxJV0xxxx] , Farmall® 115C less cab, with mechanical or power shuttle transmission [ZxJV5xxxx] , Farmall® 115C with cab, with hi-lo transmission [ZxJV0xxxx] , Farmall® 115C with cab, with mechanical or power shuttle transmission [ZxJV5xxxx] , Farmall® 85C less cab, with hi-lo transmission [ZxJV0xxxx] , Farmall® 85C less cab, with mechanical or power shuttle transmission [ZxJV5xxxx] , Farmall® 85C with cab, with hi-lo transmission [ZxJV0xxxx] , Farmall® 85C with cab, with mechanical or power shuttle transmission [ZxJV5xxxx] , Farmall® 95C less cab, with hi-lo transmission [ZxJV0xxxx] , Farmall® 95C less cab, with mechanical or power shuttle transmission [ZxJV5xxxx] , Farmall® 95C with cab, with hi-lo transmission [ZxJV0xxxx] , Farmall® 95C with cab, with mechanical or power shuttle transmission [ZxJV5xxxx]

<https://www.caseih.com>

Contents

Engine - 10

[10.001] Engine and crankcase	10.1
[10.216] Fuel tanks	10.2
[10.501] Exhaust Gas Recirculation (EGR) - Diesel Particulate Filter (DPF) exhaust treatment	10.3
[10.400] Engine cooling system	10.4
[10.414] Fan and drive	10.5
[10.310] Aftercooler.....	10.6

<https://caseihservicemanual.com>



Engine - 10

Engine and crankcase - 001

<https://caseih.servicemanual.com>

Farmall® 105C less cab, with hi-lo transmission [ZxJV0xxxx] , Farmall® 105C less cab, with mechanical or power shuttle transmission [ZxJV5xxxx] , Farmall® 105C with cab, with hi-lo transmission [ZxJV0xxxx] , Farmall® 105C with cab, with mechanical or power shuttle transmission [ZxJV5xxxx] , Farmall® 115C less cab, with hi-lo transmission [ZxJV0xxxx] , Farmall® 115C less cab, with mechanical or power shuttle transmission [ZxJV5xxxx] , Farmall® 115C with cab, with hi-lo transmission [ZxJV0xxxx] , Farmall® 115C with cab, with mechanical or power shuttle transmission [ZxJV5xxxx] , Farmall® 85C less cab, with hi-lo transmission [ZxJV0xxxx] , Farmall® 85C less cab, with mechanical or power shuttle transmission [ZxJV5xxxx] , Farmall® 85C with cab, with hi-lo transmission [ZxJV0xxxx] , Farmall® 85C with cab, with mechanical or power shuttle transmission [ZxJV5xxxx] , Farmall® 95C less cab, with hi-lo transmission [ZxJV0xxxx] , Farmall® 95C less cab, with mechanical or power shuttle transmission [ZxJV5xxxx] , Farmall® 95C with cab, with hi-lo transmission [ZxJV0xxxx] , Farmall® 95C with cab, with mechanical or power shuttle transmission [ZxJV5xxxx]

Contents

Engine - 10

Engine and crankcase - 001

SERVICE

Engine

Remove	3
Install	13

<https://caseihservicemanual.com>

Engine - Remove

1. Remove the engine hood (1), as indicated in **Hood - Remove (90.100)**.
2. Remove the battery, as described in **Battery - Remove (55.302)**.
3. Remove the tank, as described in **Fuel tank - Remove (10.216)**.
4. Loosen the retaining bolts (1). Remove the front wheel fenders (2) (if any). Do this on both sides.

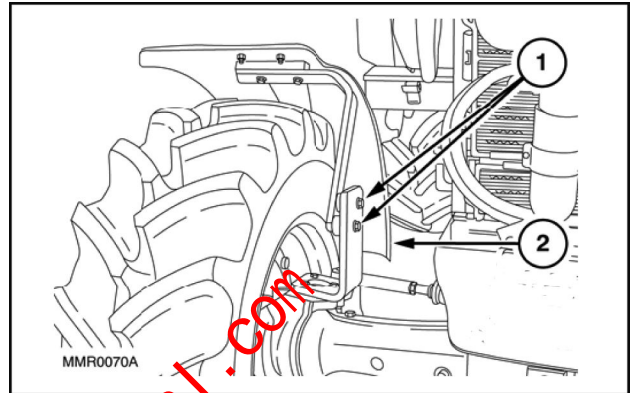

WLAPL4S10C104A 1

5. Recover the refrigerant from the system via the fittings (1) and (2) using the specific tool **380000315**. Detach the two lines by disconnecting any support straps.

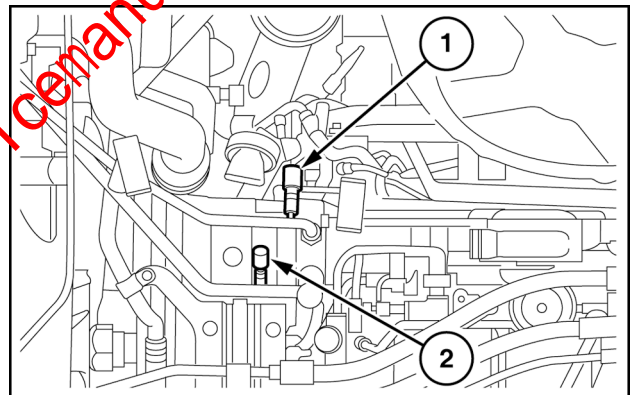

WLAPL4S10C106AA 2

6. Then detach the lower pipe (3) on the condenser (1). Free the pipe from any straps or clamps. Disconnect the sensor (2). Place the pipe on the cab.

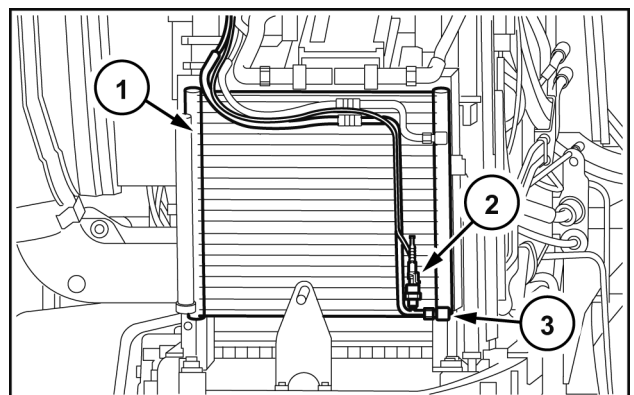

WLAPL4S10C107A 3

7. Raise the rear of the tractor with a hydraulic jack. Place a mechanical jack stand under the reduction gear case. Use a pneumatic gun to remove the retaining nuts of the left-hand rear wheel. Then remove the wheel.

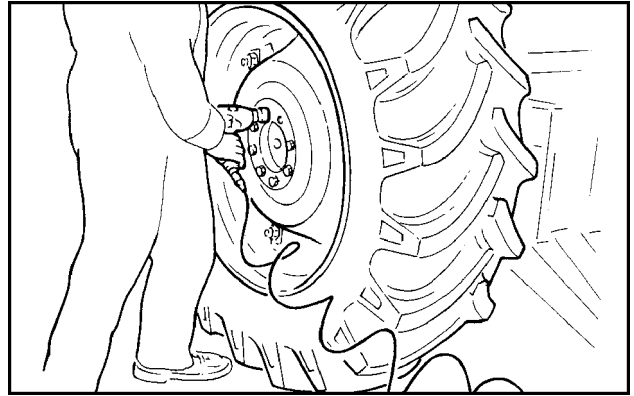

WLAPL4S10C110A 4

8. Unscrew the front, central, and rear retaining bolts on the guard of the front axle control shaft. Then remove the guard (1).

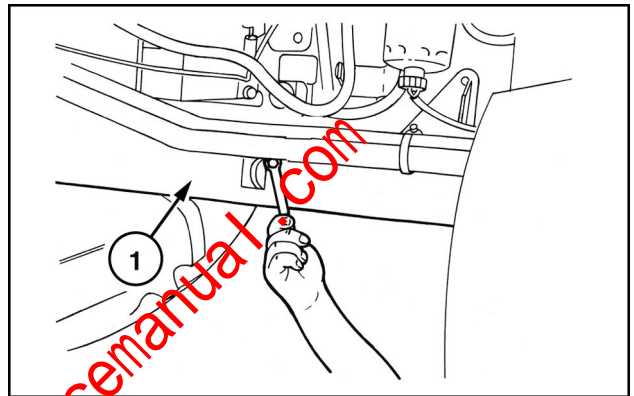

WLAPL4S10C112AA 5

9. Remove the circlip (2) and move the front sleeve (1) in the direction indicated by the arrow until it is released from the groove on the front axle.

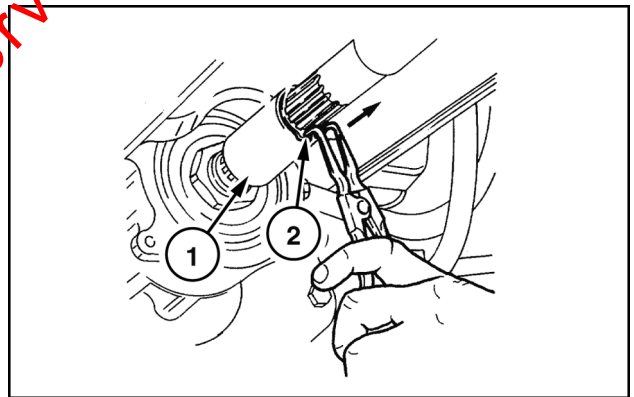

WLAPL4S10C113AA 6

10. Remove the bolts that secure the central support (1) of the drive shaft. Remove the shaft complete with the support. Also remove the shim that adjusts the clearance of the shaft on the back.

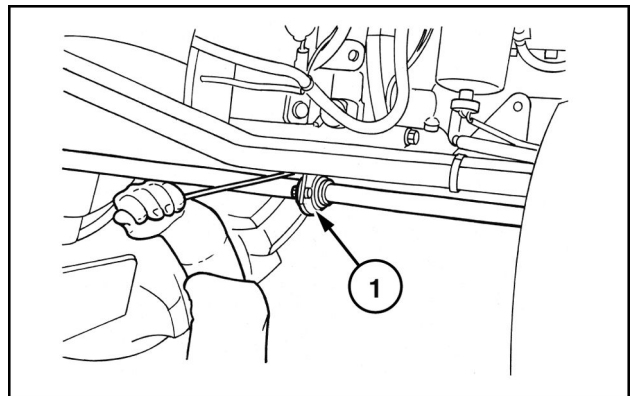

WLAPL4S10C115AA 7

<https://caseih.servicemanual.com>

11. Loosen the union of the radiator coolant return line of the cab heater. Drain and collect the engine coolant.

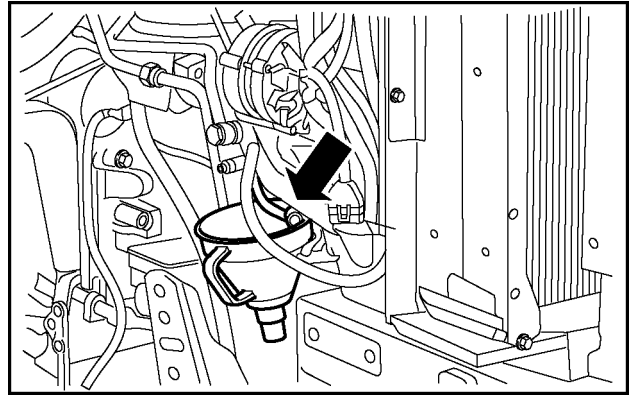

WLAPL4S10C116A 8

12. Place a suitable container under the drain plug (1) for the gearbox-transmission oil. Loosen the plug. Drain the oil.

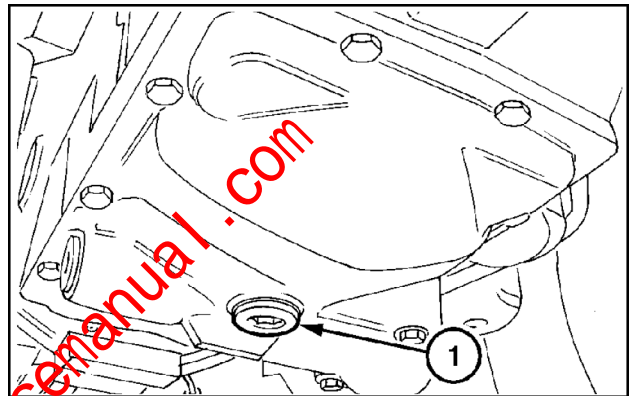

MOIL13TR00197AA 9

13. Remove the brakes reservoir heat shield (1).

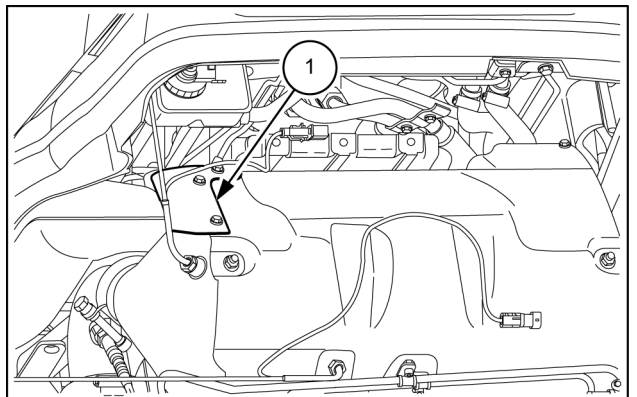

MOIL12APL98 10

14. Loosen the fixing clamp (1) to the filter DPF and the support clamp (2). Remove the exhaust pipe (3).

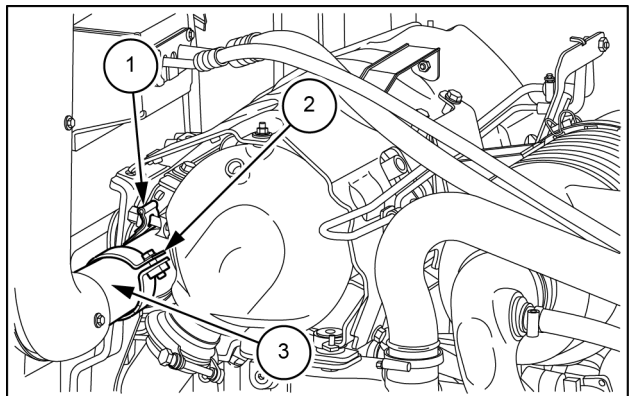

MOIL13TR01798AA 11

15. Loosen the fixing clamps (1). Extract the tubing from the turbine to the radiator intercooler (2). Perform the same operation for the tubing from the radiator intercooler to the engine (3).

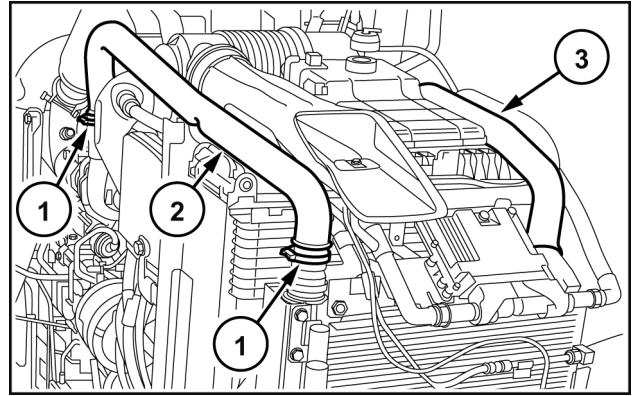

WLAPL4S10C119A 12

16. Loosen the clamp (2) that fastens the air intake duct to the turbine. Then free the air cleaner (4) together with the support bracket (3) from the screws that secure it. Disconnect the oil vapor duct (1) on the right-hand side of the engine.

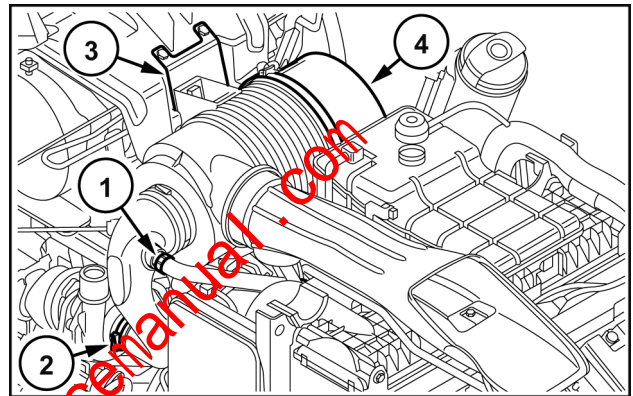

WLAPL4S10C120A 13

17. Free the air cleaner bracket – hood support (1) from the fixing screws and remove it.

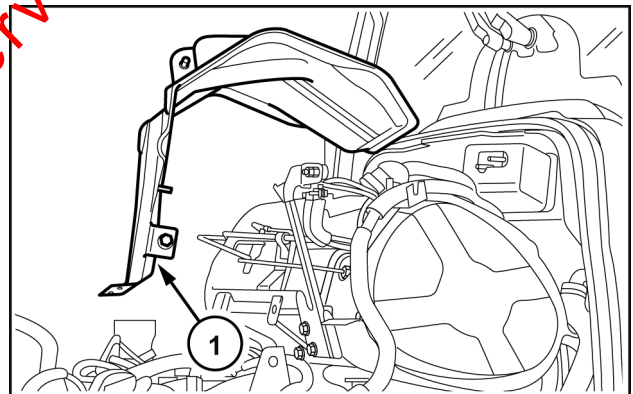

WLAPL4S10C121A 14

ATTENTION: The filter outlet union DPF (1) at its terminal (2) has a decoupler that responds to temperature variations by changing length.

A small misalignment of the axis of the decoupler with respect to the axis of the turbine outlet (3) would produce an adjustment that would no longer be lengthwise, in line with the direction of the tractor, but abnormal transversal adjustment that would impair its durability.

18. Disconnect all of the filter sensors. Loosen the clamp (4). Remove the entire filter together with the sensors, pressure sensing tubes, lambda probe, and heat shrouds by undoing the four screws (5) that secure it on the bottom cradle.

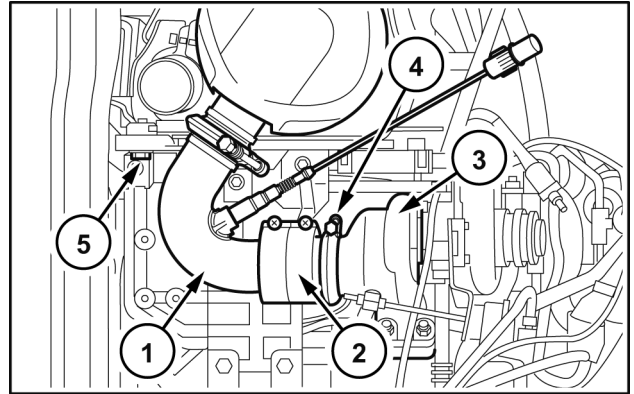

WLAPL4S10C122A 15

ATTENTION: Only if you have to work on the parts underneath the DPF filter support, it is advisable to remove the support.

The upper part (1) and the right-hand part (2) should be removed as a block, when possible, by removing the fixing screws (3) to the right-hand side of the engine. (These screws work on a vertical slot that allows the support (2) to take on various height positions). Before removal, take some references on the position of the unit on the engine so that, during re-assembly, it is possible to restore it to the exact position in which it was originally found.

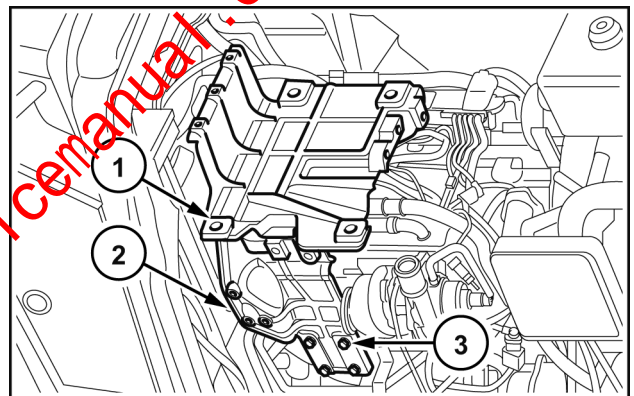

WLAPL4S10C123A 16

19. To remove the rear shield, loosen the two upper screws that fasten the support (4) to the support (1). To remove the left-hand support (5), loosen the two upper screws, the respective centring bushings that secure the left-hand bracket to the support (1). As regards removing the support (1) and (2), there are no special instructions to follow.

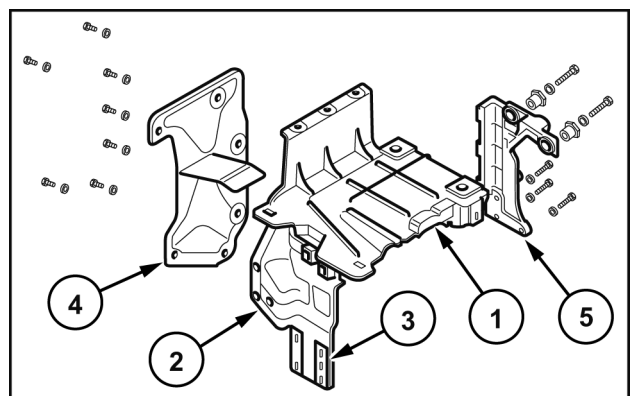

WLAPL4S10C124A 17