

<https://caseihservicemanual.com/>

MAGNUM 235
MAGNUM 260
MAGNUM 290
MAGNUM 315
MAGNUM 340

Tractor

SERVICE MANUAL

Part number 84533022

English

July 2011

Replaces part number 84474531



Contents

INTRODUCTION

HYDRAULIC, PNEUMATIC, ELECTRICAL, ELECTRONIC SYSTEMS A

PRIMARY HYDRAULIC POWER SYSTEM.....	A.10.A
PRIMARY HYDRAULIC POWER SYSTEM Electro-hydraulic remote valve.....	A.10.C
PNEUMATIC SYSTEM.....	A.20.A
ELECTRICAL POWER SYSTEM.....	A.30.A
ELECTRONIC SYSTEM.....	A.50.A
FAULT CODES.....	A.50.A

ENGINE AND PTO IN..... B

ENGINE.....	B.10.A
FUEL AND INJECTION SYSTEM.....	B.20.A
EXHAUST SYSTEM Emissions control.....	B.40.B
ENGINE COOLANT SYSTEM.....	B.50.A

TRANSMISSION, DRIVE AND PTO OUT..... C

POWER COUPLING Fixed coupling.....	C.10.B
POWER COUPLING Drop box.....	C.10.E
TRANSMISSION Powershift.....	C.20.E
REAR PTO Hydraulic.....	C.40.C
BAR AXLE.....	C.60.A

AXLES, BRAKES AND STEERING..... D

FRONT AXLE.....	D.10.A
2WD-4WD SYSTEM Hydraulic.....	D.14.C
STEERING Hydraulic.....	D.20.C
SERVICE BRAKE Hydraulic.....	D.30.C
PARKING BRAKE Hydraulic.....	D.32.C
BRAKE CONNECTION Hydraulic.....	D.34.C
BRAKE CONNECTION Pneumatic.....	D.34.E
SUSPENSION Hydraulic.....	D.40.C

FRAME AND CAB	E
SHIELD	E.20.A
USER CONTROLS AND SEAT	E.32.A
USER CONTROLS AND SEAT Operator seat	E.32.C
ENVIRONMENT CONTROL Heating, ventilation and air-conditioning.....	E.40.D
HITCH AND WORKING TOOL	H
HITCH Rear hitch.....	H.10.C

<https://caseihservicemanual.com/>

<https://caseihservicemanual.com>



INTRODUCTION

<https://caseihservicemanual.com/>

Contents

INTRODUCTION

Safety rules	3
Torque - Minimum tightening torques for normal assembly	5
Capacities	10

<https://caseihservicemanual.com/>

Safety rules

Standard safety precautions

Be informed and notify personnel of the laws in force regulating safety, and provide documentation available for consultation.

- Keep working areas as clean as possible.
- Ensure that working areas are provided with emergency boxes. They must be clearly visible and always contain adequate sanitary equipment.
- Fire extinguishers must be properly identified and always be clear of obstructions. Their efficiency must be checked on a regular basis and personnel must be trained on proper interventions and priorities.
- Keep all emergency exits free of obstructions and clearly marked.
- Smoking in working areas subject to fire danger must be strictly prohibited.

Prevention of injury

- Wear suitable work attire and safety glasses with no jewelry such as rings and chains when working close to engines and equipment in motion.
- Wear safety gloves and goggles when performing the following operations:
 - Topping off or changing lubrication oils.
 - Using compressed air or liquids at a pressure greater than **2 bar (29 psi)**.
- Wear a safety helmet when working close to hanging loads or equipment working at head level.
- Always wear safety shoes and fitting clothes.
- Use protection cream for hands.
- Change wet clothes as soon as possible.
- In the presence of voltages exceeding **48 - 60 V**, verify the efficiency of the ground and mass electrical connections. Ensure that hands and feet are dry and use isolating foot boards. Workers should be properly trained to work with electricity.
- Do not smoke or start an open flame close to batteries and any fuel material.
- Place soiled rags with oil, diesel fuel or solvents in specially provided anti-fire containers.
- Do not use any tool or equipment for any use other than what it was originally intended for. Serious injury may occur.
- If running an engine indoors, make sure there is a sufficient exhaust fan in use to eliminate exhaust fumes.

During maintenance

- Never open the filler cap of the cooling system when the engine is hot. High temperature liquid at operating pressure could result in serious danger and risk of burn. Wait until the temperature decreases under **50 °C (122 °F)**.
- Never add coolant to an overheated engine and use only appropriate liquids.
- Always work when the engine is turned off. Certain circumstances require maintenance on a running engine. Be aware of all the risks involved with such an operation.
- Always use adequate and safe containers for engine fluids and used oil.
- Keep engine clean of any spilled fluids such as oil, diesel fuel, and or chemical solvents.
- Use of solvents or detergents during maintenance may emit toxic vapors. Always keep working areas aerated. Wear a safety mask if necessary.
- Do not leave soiled rags that may contain any flammable substances close to the engine.
- Always use caution when starting an engine after any work has been performed. Be prepared to cut off intake air in case of engine runaway.
- Never disconnect the batteries while the engine is running.

- Disconnect the batteries prior to performing any work on the equipment.
- Disconnect the batteries to place a load on them with a load tester.
- After any work is performed, verify that the battery clamp polarity is correct and that the clamps are tight and safe from accidental short circuit and oxidation.
- Before disconnecting any pipelines (pneumatic, hydraulic, fuel pipes, etc.), verify that all pressure has been released. Take all necessary precautions bleeding and draining residual pressure. Always wear the proper safety equipment.
- Do not alter the lengths of any wires.
- Do not connect any electronic service tool to the engine electrical equipment unless specifically approved by Iveco.
- Do not modify the fuel system or hydraulic system unless approved by Iveco, Any unauthorized modification will compromise warranty assistance and may affect engine operation and life span.

For engine equipped with an electronic control unit

- Do not weld on any part of the equipment without removing the control unit.
- Remove the in case of work requiring heating over **80 °C (176 °F)**.
- Do not paint the components and the electronic connections.
- Do not alter any data filed in the electronic control unit driving the engine. Any manipulation or alteration of electronic components will void engine warranty assistance and may affect the correct working order and life span of the engine.

Respect of the Environment

- Respect of the environment should be of primary importance. Take all necessary precautions to ensure personnel's safety and health.
- Inform the personnel of the laws regarding the dispensing of used engine fluids.
- Handle batteries with care, storing them in a well ventilated environment and within anti-acid container.

Torque - Minimum tightening torques for normal assembly

METRIC NON-FLANGED HARDWARE

NOM. SIZE	CLASS 8.8 BOLT and CLASS 8 NUT		CLASS 10.9 BOLT and CLASS 10 NUT		LOCKNUT CL.8 W/CL8.8 BOLT	LOCKNUT CL.10 W/CL10.9 BOLT
	UNPLATED	PLATED W/ZnCr	UNPLATED	PLATED W/ZnCr		
M4	2.2 N·m (19 lb in)	2.9 N·m (26 lb in)	3.2 N·m (28 lb in)	4.2 N·m (37 lb in)	2 N·m (18 lb in)	2.9 N·m (26 lb in)
M5	4.5 N·m (40 lb in)	5.9 N·m (52 lb in)	6.4 N·m (57 lb in)	8.5 N·m (75 lb in)	4 N·m (36 lb in)	5.8 N·m (51 lb in)
M6	7.5 N·m (66 lb in)	10 N·m (89 lb in)	11 N·m (96 lb in)	15 N·m (128 lb in)	6.8 N·m (60 lb in)	10 N·m (89 lb in)
M8	18 N·m (163 lb in)	25 N·m (217 lb in)	26 N·m (234 lb in)	35 N·m (311 lb in)	17 N·m (151 lb in)	24 N·m (212 lb in)
M10	37 N·m (27 lb ft)	49 N·m (36 lb ft)	52 N·m (38 lb ft)	70 N·m (51 lb ft)	33 N·m (25 lb ft)	48 N·m (35 lb ft)
M12	64 N·m (47 lb ft)	85 N·m (63 lb ft)	91 N·m (67 lb ft)	121 N·m (90 lb ft)	58 N·m (43 lb ft)	83 N·m (61 lb ft)
M16	158 N·m (116 lb ft)	210 N·m (155 lb ft)	225 N·m (166 lb ft)	301 N·m (222 lb ft)	143 N·m (106 lb ft)	205 N·m (151 lb ft)
M20	319 N·m (235 lb ft)	425 N·m (313 lb ft)	440 N·m (325 lb ft)	587 N·m (433 lb ft)	290 N·m (214 lb ft)	400 N·m (295 lb ft)
M24	551 N·m (410 lb ft)	735 N·m (500 lb ft)	762 N·m (560 lb ft)	1016 N·m (750 lb ft)	501 N·m (370 lb ft)	693 N·m (510 lb ft)

NOTE: M4 through M8 hardware torque specifications are shown in pound-inches. M10 through M24 hardware torque specifications are shown in pound-feet.

METRIC FLANGED HARDWARE

NOM. SIZE	CLASS 8.8 BOLT and CLASS 8 NUT		CLASS 10.9 BOLT and CLASS 10 NUT		LOCKNUT CL.8 W/CL8.8 BOLT	LOCKNUT CL.10 W/CL10.9 BOLT
	UNPLATED	PLATED W/ZnCr	UNPLATED	PLATED W/ZnCr		
M4	2.4 N·m (21 lb in)	3.2 N·m (28 lb in)	3.5 N·m (31 lb in)	4.6 N·m (41 lb in)	2.2 N·m (19 lb in)	3.1 N·m (27 lb in)
M5	4.9 N·m (43 lb in)	6.5 N·m (58 lb in)	7.0 N·m (62 lb in)	9.4 N·m (83 lb in)	4.4 N·m (39 lb in)	6.4 N·m (57 lb in)
M6	8.3 N·m (73 lb in)	11 N·m (96 lb in)	12 N·m (105 lb in)	16 N·m (141 lb in)	7.5 N·m (66 lb in)	11 N·m (96 lb in)
M8	20 N·m (179 lb in)	27 N·m (240 lb in)	29 N·m (257 lb in)	39 N·m (343 lb in)	18 N·m (163 lb in)	27 N·m (240 lb in)
M10	40 N·m (30 lb ft)	54 N·m (40 lb ft)	57 N·m (42 lb ft)	77 N·m (56 lb ft)	37 N·m (27 lb ft)	53 N·m (39 lb ft)
M12	70 N·m (52 lb ft)	93 N·m (69 lb ft)	100 N·m (74 lb ft)	134 N·m (98 lb ft)	63 N·m (47 lb ft)	91 N·m (67 lb ft)
M16	174 N·m (128 lb ft)	231 N·m (171 lb ft)	248 N·m (183 lb ft)	331 N·m (244 lb ft)	158 N·m (116 lb ft)	226 N·m (167 lb ft)
M20	350 N·m (259 lb ft)	467 N·m (345 lb ft)	484 N·m (357 lb ft)	645 N·m (476 lb ft)	318 N·m (235 lb ft)	440 N·m (325 lb ft)
M24	607 N·m (447 lb ft)	809 N·m (597 lb ft)	838 N·m (618 lb ft)	1118 N·m (824 lb ft)	552 N·m (407 lb ft)	

IDENTIFICATION

Metric Hex head and carriage bolts, classes 5.6 and up

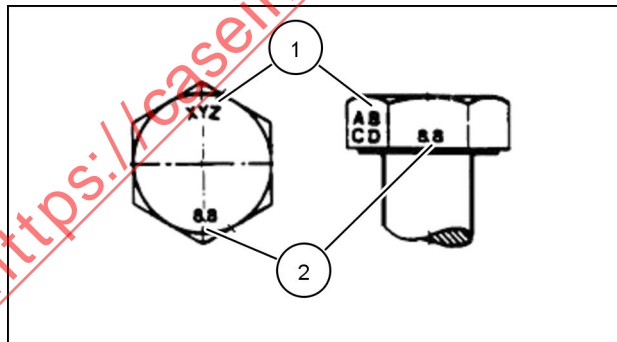

20083680 1

1. Manufacturer's Identification
2. Property Class

Metric Hex nuts and locknuts, classes 05 and up

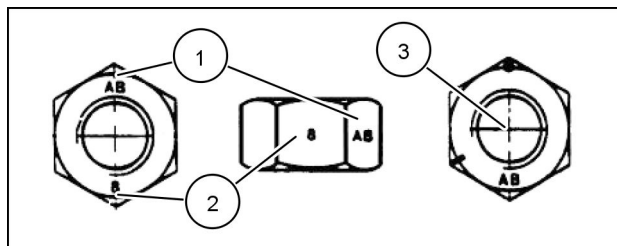

20083681 2

1. Manufacturer's Identification
2. Property Class
3. Clock Marking of Property Class and Manufacturer's Identification (Optional), i.e. marks **60 °** apart indicate Class 10 properties, and marks **120 °** apart indicate Class 8.

INCH NON-FLANGED HARDWARE

NOMINAL SIZE	SAE GRADE 5 BOLT and NUT		SAE GRADE 8 BOLT and NUT		LOCKNUT GrB W/ Gr5 BOLT	LOCKNUT GrC W/ Gr8 BOLT
	UN-PLATED or PLATED SILVER	PLATED W/ZnCr GOLD	UN-PLATED or PLATED SILVER	PLATED W/ZnCr GOLD		
1/4	8 N·m (71 lb in)	11 N·m (97 lb in)	12 N·m (106 lb in)	16 N·m (142 lb in)	8.5 N·m (75 lb in)	12.2 N·m (109 lb in)
5/16	17 N·m (150 lb in)	23 N·m (204 lb in)	24 N·m (212 lb in)	32 N·m (283 lb in)	17.5 N·m (155 lb in)	25 N·m (220 lb in)
3/8	30 N·m (22 lb ft)	40 N·m (30 lb ft)	43 N·m (31 lb ft)	57 N·m (42 lb ft)	31 N·m (23 lb ft)	44 N·m (33 lb ft)
7/16	48 N·m (36 lb ft)	65 N·m (48 lb ft)	68 N·m (50 lb ft)	91 N·m (67 lb ft)	50 N·m (37 lb ft)	71 N·m (53 lb ft)
1/2	74 N·m (54 lb ft)	98 N·m (73 lb ft)	104 N·m (77 lb ft)	139 N·m (103 lb ft)	76 N·m (56 lb ft)	108 N·m (80 lb ft)
9/16	107 N·m (79 lb ft)	142 N·m (105 lb ft)	150 N·m (111 lb ft)	201 N·m (148 lb ft)	111 N·m (82 lb ft)	156 N·m (115 lb ft)
5/8	147 N·m (108 lb ft)	196 N·m (145 lb ft)	208 N·m (153 lb ft)	277 N·m (204 lb ft)	153 N·m (113 lb ft)	215 N·m (159 lb ft)
3/4	261 N·m (193 lb ft)	348 N·m (257 lb ft)	369 N·m (272 lb ft)	491 N·m (362 lb ft)	271 N·m (200 lb ft)	383 N·m (282 lb ft)
7/8	420 N·m (310 lb ft)	561 N·m (413 lb ft)	594 N·m (438 lb ft)	791 N·m (584 lb ft)	437 N·m (323 lb ft)	617 N·m (455 lb ft)
1	630 N·m (465 lb ft)	841 N·m (620 lb ft)	890 N·m (656 lb ft)	1187 N·m (875 lb ft)	654 N·m (483 lb ft)	924 N·m (681 lb ft)

NOTE: For Imperial Units, 1/4 in and 5/16 in hardware torque specifications are shown in pound-inches. 3/8 in through 1 in hardware torque specifications are shown in pound-feet.

INCH FLANGED HARDWARE

NOM- INAL SIZE	SAE GRADE 5 BOLT and NUT		SAE GRADE 8 BOLT and NUT		LOCKNUT GrF W/ Gr5 BOLT	LOCKNUT GrG W/ Gr8 BOLT
	UNPLATED or PLATED SILVER	PLATED W/ZnCr GOLD	UNPLATED or PLATED SILVER	PLATED W/ZnCr GOLD		
1/4	9 N·m (80 lb in)	12 N·m (106 lb in)	13 N·m (115 lb in)	17 N·m (150 lb in)	8 N·m (71 lb in)	12 N·m (106 lb in)
5/16	19 N·m (168 lb in)	25 N·m (221 lb in)	26 N·m (230 lb in)	35 N·m (310 lb in)	17 N·m (150 lb in)	24 N·m (212 lb in)
3/8	33 N·m (25 lb ft)	44 N·m (33 lb ft)	47 N·m (35 lb ft)	63 N·m (46 lb ft)	30 N·m (22 lb ft)	43 N·m (32 lb ft)
7/16	53 N·m (39 lb ft)	71 N·m (52 lb ft)	75 N·m (55 lb ft)	100 N·m (74 lb ft)	48 N·m (35 lb ft)	68 N·m (50 lb ft)
1/2	81 N·m (60 lb ft)	108 N·m (80 lb ft)	115 N·m (85 lb ft)	153 N·m (113 lb ft)	74 N·m (55 lb ft)	104 N·m (77 lb ft)
9/16	117 N·m (86 lb ft)	156 N·m (115 lb ft)	165 N·m (122 lb ft)	221 N·m (163 lb ft)	106 N·m (78 lb ft)	157 N·m (116 lb ft)
5/8	162 N·m (119 lb ft)	216 N·m (159 lb ft)	228 N·m (168 lb ft)	304 N·m (225 lb ft)	147 N·m (108 lb ft)	207 N·m (153 lb ft)
3/4	287 N·m (212 lb ft)	383 N·m (282 lb ft)	405 N·m (299 lb ft)	541 N·m (399 lb ft)	261 N·m (193 lb ft)	369 N·m (272 lb ft)
7/8	462 N·m (341 lb ft)	617 N·m (455 lb ft)	653 N·m (482 lb ft)	871 N·m (642 lb ft)	421 N·m (311 lb ft)	594 N·m (438 lb ft)
1	693 N·m (512 lb ft)	925 N·m (682 lb ft)	979 N·m (722 lb ft)	1305 N·m (963 lb ft)	631 N·m (465 lb ft)	890 N·m (656 lb ft)

IDENTIFICATION

Inch Bolts and free-spinning nuts

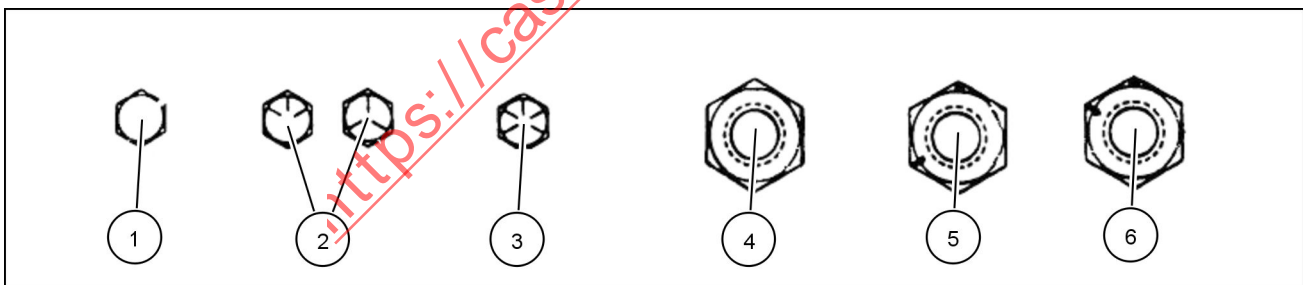

20083682 3

Grade Marking Examples

SAE Grade Identification			
1	Grade 2 - No Marks	4	Grade 2 Nut - No Marks
2	Grade 5 - Three Marks	5	Grade 5 Nut - Marks 120 ° Apart
3	Grade 8 - Five Marks	6	Grade 8 Nut - Marks 60 ° Apart

Inch Lock Nuts, All Metal (Three optional methods)

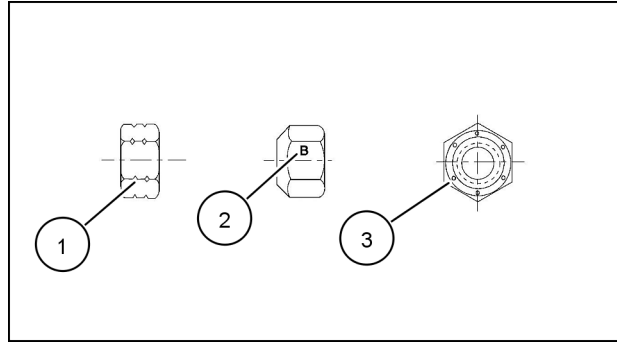

20090268 4

Grade Identification

Grade	Corner Marking Method (1)	Flats Marking Method (2)	Clock Marking Method (3)
Grade A	No Notches	No Mark	No Marks
Grade B	One Circumferential Notch	Letter B	Three Marks
Grade C	Two Circumferential Notches	Letter C	Six Marks

<https://caseihservicemanual.com/>

Capacities

System	Metric	U.S.	Imperial
9.0 l engine			
Engine oil – no filter change	25 l	6.6 US gal	5.5 UK gal
Engine oil – with filter change	25 l	6.6 US gal	5.5 UK gal
Cooling system	26.5 l	7 US gal	5.8 UK gal
Transmission/hydraulic system	172 l	45.5 US gal	38 UK gal
Mechanical front drive			
4 pin – 100 mm (4 in) hub length standard axle*			
Differential	11.8 l	12 US qt	21.6 UK pt
Planetary (each)	1.4 l	3 US pt	2.4 UK pt
4 pin – 180 mm (7 in) hub length heavy duty axle*			
Differential	11.8 l	12.5 US qt	20.5 UK pt
Planetary (each)	3.3 l	7 US pt	5.8 UK pt
3 pin – 250 mm (10 in) hub length heavy duty class 5 axle			
Differential	15 l	15.8 US qt	26.4 UK pt
Planetary (each)	6 l	12.7 US pt	10.5 UK pt
Front PTO	3.05 l	3.2 US qt	--
DEF/AdBLUE® tank	87 l	23 US gal	23.8 UK gal
Fuel tank	636 l	168 US gal	140 UK gal

* Pin quantity is determined by observing the wheel ends.



SERVICE MANUAL

HYDRAULIC, PNEUMATIC, ELECTRICAL, ELECTRONIC SYSTEMS

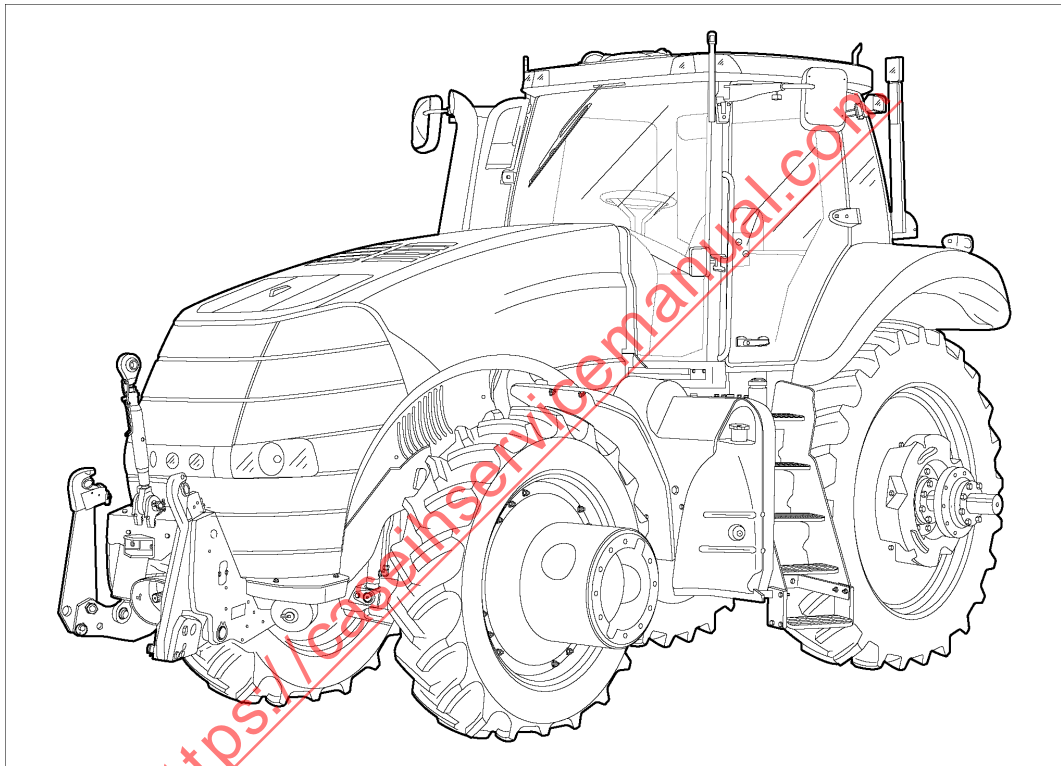

Magnum 235
Magnum 260
Magnum 290
Magnum 315
Magnum 340

Contents

HYDRAULIC, PNEUMATIC, ELECTRICAL, ELECTRONIC SYSTEMS - A

PRIMARY HYDRAULIC POWER SYSTEM	A.10.A
Magnum 235 , Magnum 260 , Magnum 290 , Magnum 315 , Magnum 340	
PRIMARY HYDRAULIC POWER SYSTEM Electro-hydraulic remote valve	A.10.C
Magnum 235 , Magnum 260 , Magnum 290 , Magnum 315 , Magnum 340	
PNEUMATIC SYSTEM	A.20.A
Magnum 235 , Magnum 260 , Magnum 290 , Magnum 315 , Magnum 340	
ELECTRICAL POWER SYSTEM	A.30.A
Magnum 235 , Magnum 260 , Magnum 290 , Magnum 315 , Magnum 340	
ELECTRONIC SYSTEM	A.50.A
Magnum 235 , Magnum 260 , Magnum 290 , Magnum 315 , Magnum 340	
FAULT CODES	A.50.A
Magnum 235 , Magnum 260 , Magnum 290 , Magnum 315 , Magnum 340	

<https://caseihservicemanual.com/>



HYDRAULIC, PNEUMATIC, ELECTRICAL, ELECTRONIC SYSTEMS - A

PRIMARY HYDRAULIC POWER SYSTEM - 10.A

<https://caseihservicemanual.com/>

Magnum 235
Magnum 260
Magnum 290
Magnum 315
Magnum 340

Contents

HYDRAULIC, PNEUMATIC, ELECTRICAL, ELECTRONIC SYSTEMS - A

PRIMARY HYDRAULIC POWER SYSTEM - 10.A

TECHNICAL DATA

Pressure/flow compensating (PFC) pump	
Torque	4

FUNCTIONAL DATA

PRIMARY HYDRAULIC POWER SYSTEM	
Hydraulic schematic frame 01	6
Hydraulic symbol - Schematic components	9
Hydraulic symbol - Pressure control	15
Hydraulic symbol - Directional control	17
Hydraulic symbol - Composite	18
Hydraulic symbol - Flow control	21
Hydraulic symbol - Table of symbols	22
Power beyond	
Dynamic description	26
Hydraulic pump	
Dynamic description	28
Tandem gear pump Charge and lubrication - Component identification	38
Motor return	
Component identification	39
Control valve	
Priority/Regulator valve - Dynamic description	40
Priority/Regulator valve - Exploded view	43
Priority/Regulator valve - Sectional view	45
Pressure/flow compensating (PFC) pump	
Dynamic description	47
Standard - Component identification	50
High flow - Component identification	52
Dual flow - Component identification - Pump layout	54

SERVICE

Hydraulic pump	
----------------	--

Tandem gear pump Charge and lubrication - Pressure test	56
Tandem gear pump Charge and lubrication - Remove	58
Tandem gear pump Charge and lubrication - Install	62
Suction screen	
Remove	65
Cleaning	70
Install	71
Pump drive	
Remove	75
Disassemble	77
Assemble	81
End play	86
Install	87
Control valve	
Priority/Regulator valve - Pressure test	89
Priority/Regulator valve - Leakage test	90
Priority/Regulator valve - Adjust	93
Priority/Regulator valve - Remove	94
Priority/Regulator valve - Disassemble	97
Priority/Regulator valve - Assemble	101
Priority/Regulator valve - Install	104
Flow compensator - Adjust - Low pressure standby setting	107
Flow compensator - Inspect	109
Pressure/flow compensating (PFC) pump	
Standard - Flow test - At the remote couplers	110
Dual flow - Flow test - At the remote coupler	112
Standard - Flow test At the pump outlet	114
High flow - Flow test - At the pump outlet	117
Dual flow - Flow test - At the pump outlet	120
Pressure test - High pressure standby setting	123
Remove - Standard or high flow	124
Install - Standard and high flow	127
Dual flow - Remove	131
Dual flow - Install	133

Pressure/flow compensating (PFC) pump - Torque

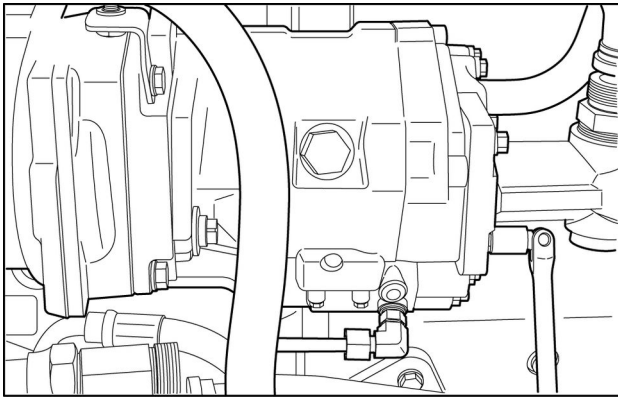
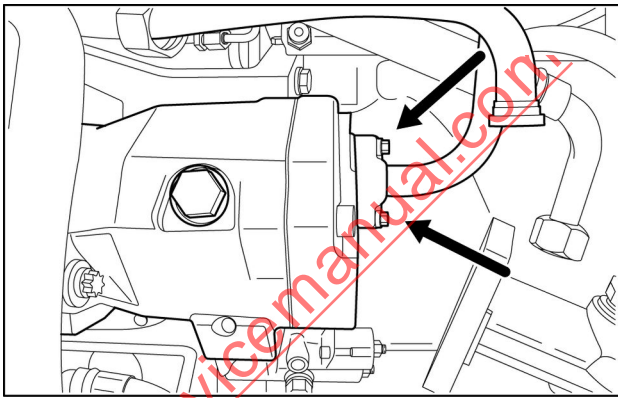
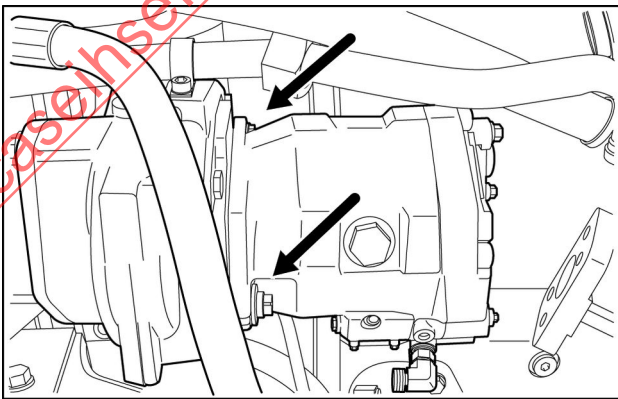
Component	Nm	Identification	lb-ft
Filter head retaining bolts	62 - 80 Nm	 <p>RCPH11CCH433AAA 1</p>	46 - 59 lb ft
Pressure and flow compensating (PFC) pump split flange retaining bolts	40 - 60 Nm	 <p>RCPH11CCH435AAA 2</p>	30 - 44 lb ft
Pressure and flow compensating (PFC) pump mounting bolts	62 - 80 Nm	 <p>RCPH11CCH437AAA 3</p>	46 - 59 lb ft

<https://caseihservicemanual.com/>

PRIMARY HYDRAULIC POWER SYSTEM - Hydraulic schematic frame 01

Hydraulic schematic 84414788

	PFC PISTON PUMP
	CHARGE LUBE/LUBE PUMP FLOW
	REGULATED CIRCUIT PRESSURE
	RETURN TO TANK/SUMP
	OIL COOLER/FILTRATION, AUX CHARGE PUMP FLOW
1. Remote section	31. Transmission control valves
2. Load sense diagnostic	32. Park clutch
3. Pilot/hitch drain	33. Inlet regulator
4. Pilot supply	34. Priority regulator valve
5. Return	35. Thermal bypass valve
6. Supply	36. Oil cooler
7. Hitch valve	37. Lube regulator
8. Category 4 hitch	38. Piston pump
9. Hitch cylinders	39. Filter
10. Return	40. PTO lube
11. Supply	41. Odd/even lube
12. Signal	42. Drop box lube
13. Case drain	43. Creep drive lube
14. Power beyond	44. Master clutch lube
15. PTO/differential lock valve	45. Right brake/differential lube
16. PTO clutch/brake	46. MFD/range lube
17. Differential lock clutch	47. Left brake/differential lube
18. Bevel pinion lube	48. To park brake valve
19. Lube supply	49. Service brake
20. MFD clutch	50. Master clutch
21. Low clutch	51. Inlet
22. Medium clutch	52. Master clutch inching valve
23. Hitch clutch	53. Park/emergency brake
24. Reverse clutch	54. Brake release pump
25. Fifth clutch	55. Steering hand pump
26. Third clutch	56. Steering cylinders
27. First clutch	57. Bypass valve
28. Even clutch	58. Brake valve
29. Odd clutch	59. NOTE: Switch is opened when pedal reaches full stroke when hydraulic power is lost.
30. Creeper clutch	

HYDRAULIC, PNEUMATIC, ELECTRICAL, ELECTRONIC SYSTEMS - PRIMARY HYDRAULIC POWER SYSTEM

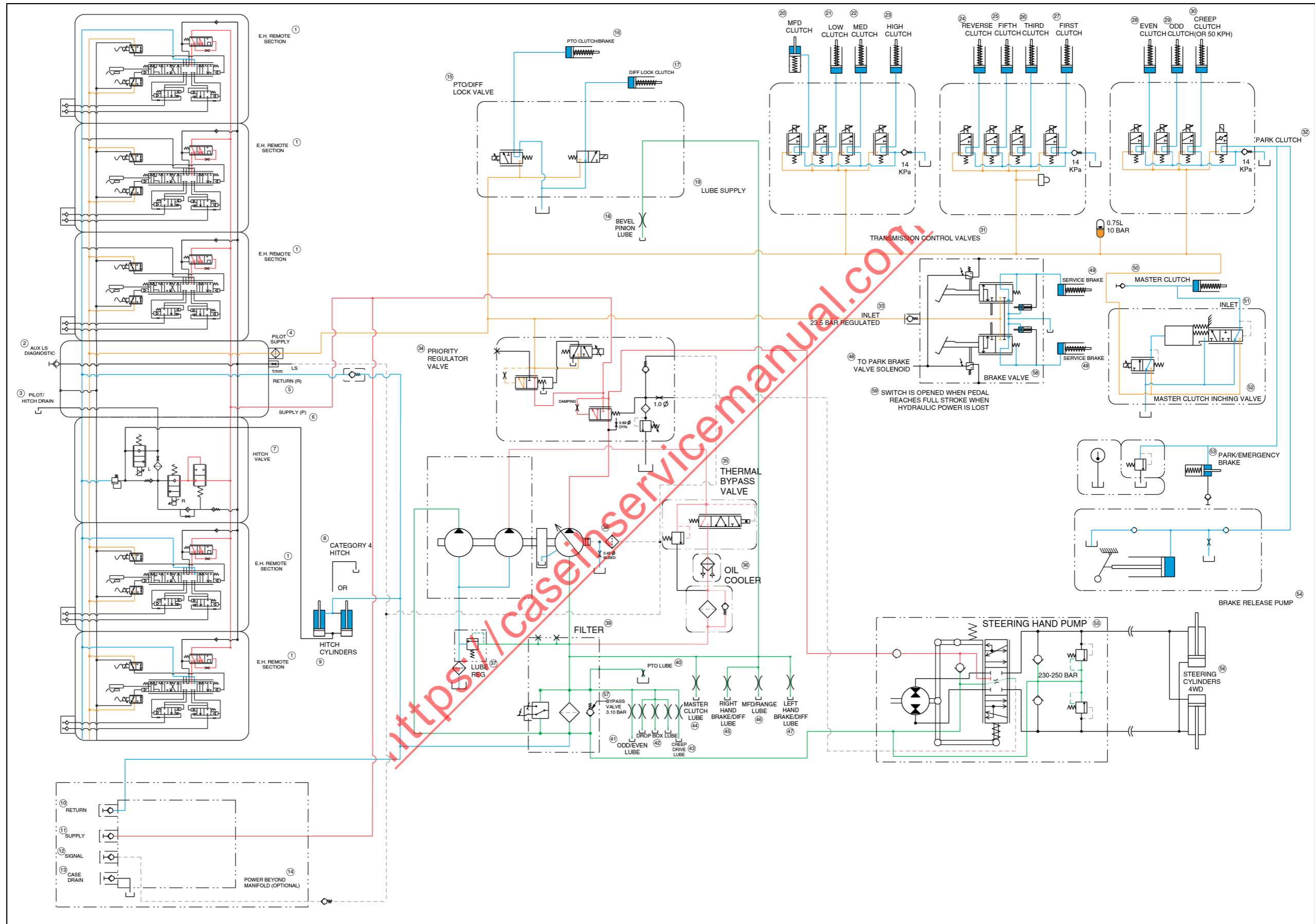

RCIL11CCH300JAA 1

<https://caseihservicemanual.com>