



SERVICE MANUAL



**PUMA 170 CVT , PUMA 170 , PUMA 185 CVT , PUMA 185 , PUMA 200 CVT ,
PUMA 200 , PUMA 215 CVT , PUMA 215 , PUMA 230 CVT**

Contents

INTRODUCTION

HYDRAULIC, PNEUMATIC, ELECTRICAL, ELECTRONIC SYSTEMS A

PRIMARY HYDRAULIC POWER SYSTEM.....	A.10.A
PRIMARY HYDRAULIC POWER SYSTEM Closed center mechanical remote valve ...	A.10.B
PRIMARY HYDRAULIC POWER SYSTEM Electro-hydraulic remote valve.....	A.10.C
SECONDARY HYDRAULIC POWER SYSTEM.....	A.12.A
HYDRAULIC COMMAND SYSTEM.....	A.14.A
PNEUMATIC SYSTEM.....	A.20.A
ELECTRICAL POWER SYSTEM.....	A.30.A
ELECTRONIC SYSTEM.....	A.50.A
FAULT CODES.....	A.50.A

ENGINE AND PTO IN B

ENGINE.....	B.10.A
FUEL AND INJECTION SYSTEM.....	B.20.A
AIR INTAKE SYSTEM.....	B.30.A
EXHAUST SYSTEM.....	B.40.A
EXHAUST SYSTEM Emissions control.....	B.40.B
ENGINE COOLANT SYSTEM.....	B.50.A

TRANSMISSION, DRIVE AND PTO OUT C

TRANSMISSION Powershift.....	C.20.E
TRANSMISSION Continuously Variable Transmission (CVT).....	C.20.G
ADDITIONAL REDUCERS Creeper.....	C.30.C
ADDITIONAL REDUCERS Overdrive.....	C.30.D
REAR PTO Mechanical.....	C.40.B
REAR PTO Hydraulic.....	C.40.C
FRONT PTO Hydraulic.....	C.42.C

AXLES, BRAKES AND STEERING..... D

FRONT AXLE.....	D.10.A
-----------------	--------

REAR AXLE	D.12.A
2WD-4WD SYSTEM Hydraulic	D.14.C
STEERING Hydraulic	D.20.C
STEERING Autoguidance	D.20.E
SERVICE BRAKE Hydraulic	D.30.C
SERVICE BRAKE Pneumatic	D.30.E
PARKING BRAKE Mechanical	D.32.B
PARKING BRAKE Electronic	D.32.D
BRAKE CONNECTION Hydraulic	D.34.C
SUSPENSION Hydraulic	D.40.C
WHEELS AND TRACKS Wheels	D.50.C
FRAME AND CAB	E
USER CONTROLS AND SEAT	E.32.A
USER PLATFORM	E.34.A
ENVIRONMENT CONTROL Heating, ventilation and air-conditioning	E.40.D
HITCH AND WORKING TOOL	H
HITCH Front hitch	H.10.B
HITCH Rear hitch	H.10.C
HITCH Electronic draft control	H.10.D





INTRODUCTION



Contents

INTRODUCTION

Advice - Important notice regarding equipment servicing	3
Safety rules	4
Basic instructions - How To Use and Navigate Through This Manual	5
Torque - Minimum tightening torques for normal assembly	10
Torque - Standard torque data for hydraulics	15
General specification - Biodiesel Fuels	17



Advice - Important notice regarding equipment servicing

All repair and maintenance work listed in this manual must be carried out only by qualified dealership personnel, strictly complying with the instructions given, and using, whenever possible, the special tools.

Anyone who performs repair and maintenance operations without complying with the procedures provided herein shall be responsible for any subsequent damages.

The manufacturer and all the organizations of its distribution chain, including - without limitation - national, regional, or local dealers, reject any responsibility for damages caused by parts and/or components not approved by the manufacturer, including those used for the servicing or repair of the product manufactured or marketed by the manufacturer. In any case, no warranty is given or attributed on the product manufactured or marketed by the manufacturer in case of damages caused by parts and/or components not approved by the manufacturer.

The information in this manual is up-to-date at the date of the publication. It is the policy of the manufacturer for continuous improvement. Some information could not be updated due to modifications of a technical or commercial type, or changes to the laws and regulations of different countries.

In case of questions, refer to your Sales and Service Networks.



Safety rules

Personal safety





This is the safety alert symbol. It is used to alert you to potential personal injury hazards. Obey all safety messages that follow this symbol to avoid possible death or injury.

Throughout this manual and on machine decals, you will find the signal words DANGER, WARNING, and CAUTION followed by special instructions. These precautions are intended for the personal safety of you and those working with you.

Read and understand all the safety messages in this manual before you operate or service the machine.

 DANGER indicates a hazardous situation which, if not avoided, will result in death or serious injury. The color associated with DANGER is RED.

 WARNING indicates a hazardous situation which, if not avoided, could result in death or serious injury. The color associated with WARNING is ORANGE.

 CAUTION, used with the safety alert symbol, indicates a hazardous situation which, if not avoided, could result in minor or moderate injury. The color associated with CAUTION is YELLOW.

FAILURE TO FOLLOW DANGER, WARNING, AND CAUTION MESSAGES COULD RESULT IN DEATH OR SERIOUS INJURY.

Machine safety

NOTICE: Notice indicates a situation which, if not avoided, could result in machine or property damage. The color associated with Notice is BLUE.

Throughout this manual you will find the signal word Notice followed by special instructions to prevent machine or property damage. The word Notice is used to address practices not related to personal safety.

Information

NOTE: Note indicates additional information which clarifies steps, procedures, or other information in this manual.

Throughout this manual you will find the word Note followed by additional information about a step, procedure, or other information in the manual. The word Note is not intended to address personal safety or property damage.

Basic instructions - How To Use and Navigate Through This Manual

Technical Information

This manual has been produced by a new technical information system. This new system is designed to deliver technical information electronically through Web delivery, DVD and in paper manuals. A coding system called SAP has been developed to link the technical information to other Product Support functions, e.g., Warranty.

Technical information is written to support the maintenance and service of the functions or systems on a customer's machine. When a customer has a concern on his machine it is usually because a function or system on his machine is not working at all, is not working efficiently, or is not responding correctly to his commands. When you refer to the technical information in this manual to resolve that customer's concern, you will find all the information classified using the SAP coding, according to the functions or systems on that machine. Once you have located the technical information for that function or system then you will find all the mechanical, electrical or hydraulic devices, components, assemblies and sub assemblies for that function or system. You will also find all the types of information that have been written for that function or system, the technical data (specifications), the functional data (how it works), the diagnostic data (fault codes and troubleshooting) and the service data (remove, install adjust, etc.).

By integrating SAP coding into technical information, you will be able to search and retrieve just the right piece of technical information you need to resolve that customer's concern on his machine. This is made possible by attaching 3 categories to each piece of technical information during the authoring process.

The first category is the Location, the second category is the Information Type and the third category is the Product:

- LOCATION - is the component or function on the machine, that the piece of technical information is going to describe e.g. Fuel tank.
- INFORMATION TYPE - is the piece of technical information that has been written for a particular component or function on the machine e.g. Capacity would be a type of Technical Data that would describe the amount of fuel held by the Fuel tank.
- PRODUCT - is the model for which the piece of technical information is written.

Every piece of technical information will have those 3 categories attached to it. You will be able to use any combination of those categories to find the right piece of technical information you need to resolve that customer's concern on his machine.

That information could be:

- the description of how to remove the cylinder head
- a table of specifications for a hydraulic pump
- a fault code
- a troubleshooting table
- a special tool

How to Use this Manual

This manual is divided into Sections. Each Section is then divided into Chapters. Contents pages are included at the beginning of the manual, then inside every Section and inside every Chapter. An alphabetical Index is included at the end of a Chapter. Page number references are included for every piece of technical information listed in the Chapter Contents or Chapter Index.

Each Chapter is divided into four Information types:

- Technical Data (specifications) for all the mechanical, electrical or hydraulic devices, components and assemblies.
- Functional Data (how it works) for all the mechanical, electrical or hydraulic devices, components and assemblies.
- Diagnostic Data (fault codes, electrical and hydraulic troubleshooting) for all the mechanical, electrical or hydraulic devices, components and assemblies.
- Service Data (remove disassembly, assemble, install) for all the mechanical, electrical or hydraulic devices, components and assemblies.

Sections

Sections are grouped according to the main functions or a systems on the machine. Each Section is identified by a letter A, B, C etc. The amount of Sections included in the manual will depend on the type and function of the machine that the manual is written for. Each Section has a Contents page listed in alphabetic/numeric order. This table illustrates which Sections could be included in a manual for a particular product.

PRODUCT	SECTION										
	A - Hydraulic – Pneumatic – Electrical – Electronic Systems										
	B - Engine and PTO In										
	C - Transmission, Drive and PTO Out										
	D - Axles, Brakes and Steering										
	E - Frame and Cab										
	F - Frame Positioning										
	G - Tool Positioning										
	H - Hitch and Working Tool										
	J - Excavating and Landscaping										
	K - Crop Processing										
L - Field Processing											
Tractors	X	X	X	X	X	X		X	X		
Vehicles with working arms: backhoes, excavators, skid steers,	X	X	X	X	X	X	X	X	X		
Combines, forage harvesters, balers,	X	X	X	X	X	X	X	X	X	X	
Seeding, planting, floating, spraying equipment,	X	X	X	X	X	X		X		X	
Mounted equipment and tools,					X	X	X		X		

Section Contents

SECTION	LETTER	DESCRIPTION
HYDRAULIC – PNEUMATIC – ELECTRICAL – ELECTRONIC SYSTEMS	A	This Section covers the main systems that interact with most of the functions of the product. It includes the central parts of the hydraulic, electrical, electronic, pneumatic, lighting and grease lubrication systems. The components that are dedicated to a specific function are listed in the Chapter where all the technical information for that function is included.
ENGINE AND PTO IN	B	This Section covers all the functions related to the production of power to move the machine and to drive various devices. In the case of a pulled-type machine, this Section covers the power take-off function where power is provided from the towing machine.
TRANSMISSION, DRIVE AND PTO OUT	C	This Section covers all the functions related to the transmission of power from the engine to the axles and to internal or external devices. This Section also covers the power take-off function where power is provided to the pull-type machine and additional Process Drive functions.
AXLES, BRAKES AND STEERING	D	This Section covers all the functions related to moving the machine, including tracks, wheels, steering and braking. It covers all the axles; both driven axles and non-driven axles, including any axle suspension.
FRAME AND CAB	E	This Section covers all the main functions and systems related to the structure and the body of the machine, including the frame, the shields, the operators cab and the platform. The functions related to the positioning of the machine frame are included in Section F, Frame Positioning.
FRAME POSITIONING	F	This Section covers all the main functions and systems related to positioning of the machine frame or to positioning the attachment on the supporting machine frame.
TOOL POSITIONING	G	This Section covers all the functions related to the final and/or automatic positioning of the tool once the tool is positioned using the Working Arm or the machine frame.
HITCH AND WORKING TOOL	H	This Section covers all the functions related to the articulated or single arms mounted on the front or rear of the machine. A working arm can have various tools and quick couplers mounted on it. The tools and quick couplers are included in Section J, Excavating and Landscaping.
EXCAVATING AND LANDSCAPING	J	This Section covers all the functions related to the specific tools that mount on the front, rear or beside the machine. The tools described here can be mounted with the positioning systems (lifting, side shift, swing) listed in Section G Tool Positioning. This Section covers all the quick coupling systems, located between the tool and the positioning system. The tools used for field preparation, soil preparation and treatment, planting and seeding are included.
CROP PROCESSING	K	This Section covers all the functions related to crop processing. Examples of crop processing include threshing, baling, windrowing, cutting and conditioning.
FIELD PROCESSING	L	This Section covers all the field processing functions of the machine. Examples of field process include seeding, fertilizer application, seedbed preparation and chemical application.

This manual contains these Sections:

Contents

INTRODUCTION	
HYDRAULIC – PNEUMATIC – ELECTRICAL – ELECTRONIC SYSTEMS	A
ENGINE AND PTO IN	B
FRAME POSITIONING	F
CROP PROCESSING	K

Chapters

Each Chapter is identified by a letter and number combination e.g. Engine B.10.A The first letter is identical to the Section letter i.e. Chapter B.10 is inside Section B, Engine and PTO In.

CONTENTS

The Chapter Contents lists all the technical data (specifications), functional data (how it works), service data (remove, install adjust, etc..) and diagnostic data (fault codes and troubleshooting) that have been written in that Chapter for that function or system on the machine.

Contents

ENGINE AND PTO IN
ENGINE _ 10.A

TECHNICAL DATA

ENGINE - General specification (B.10.A)

FUNCTIONAL DATA

ENGINE - Dynamic description (B.10.A)

SERVICE

ENGINE - Remove (B.10.A)

DIAGNOSTIC

ENGINE - Troubleshooting (B.10.A)

INDEX

The Chapter Index lists in alphabetical order all the types of information (called Information Units) that have been written in that Chapter for that function or system on the machine.

Index

ENGINE AND PTO IN - B
ENGINE

ENGINE - Dynamic description (B.10.A)

ENGINE - General specification (B.10.A)

ENGINE - Remove (B.10.A)

ENGINE - Troubleshooting (B.10.A)

Information Units and Information Search

Each chapter is composed of information units. Each information unit has the SAP code shown in parentheses which indicates the function and the type of information written in that information unit. Each information unit has a page reference within that Chapter. The information units provide a quick and easy way to find just the right piece of technical information you are looking for.

Example information unit	Stack valve - Sectional View (A.10.A.18)		
Information Unit SAP code	A	10.A	18
SAP code classification	Hydraulic – Pneumatic – Electrical – Electronic Systems	Primary hydraulic power	Stack valve

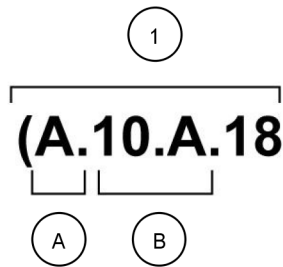

CRIL03J033E01A 1

Navigate to the correct information unit you are searching for by identifying the function and information type from the SAP code.

- **(1)** Function and ~~**(2)** Information type.~~
- **(A)** corresponds to the sections of the repair manual.
(B) corresponds to the chapters of the repair manual.
(C) corresponds to the type of information listed in the chapter contents, Technical Data, Functional Data, Diagnostic or Service.
(A) and **(B)** are also shown in the page numbering on the page footer.
THE REST OF THE CODING IS NOT LISTED IN ALPHANUMERIC ORDER IN THIS MANUAL.
- You will find a table of contents at the beginning and end of each section and chapter.
You will find an alphabetical index at the end of each chapter.
- By referring to **(A)**, **(B)** and **(C)** of the coding, you can follow the contents or index (page numbers) and quickly find the information you are looking for.

Page Header and Footer

The page header will contain the following references:

- Section and Chapter description

The page footer will contain the following references:

- Publication number for that Manual, Section or Chapter.
- Version reference for that publication.
- Publication date
- Section, chapter and page reference e.g. A.10.A / 9

Torque - Minimum tightening torques for normal assembly

METRIC NON-FLANGED HARDWARE

NOM. SIZE	CLASS 8.8 BOLT and CLASS 8 NUT		CLASS 10.9 BOLT and CLASS 10 NUT		LOCKNUT CL.8 W/CL8.8 BOLT	LOCKNUT CL.10 W/CL10.9 BOLT
	UNPLATED	PLATED W/ZnCr	UNPLATED	PLATED W/ZnCr		
M4	2.2 N·m (19 lb in)	2.9 N·m (26 lb in)	3.2 N·m (28 lb in)	4.2 N·m (37 lb in)	2 N·m (18 lb in)	2.9 N·m (26 lb in)
M5	4.5 N·m (40 lb in)	5.9 N·m (52 lb in)	6.4 N·m (57 lb in)	8.5 N·m (75 lb in)	4 N·m (36 lb in)	5.8 N·m (51 lb in)
M6	7.5 N·m (66 lb in)	10 N·m (89 lb in)	11 N·m (96 lb in)	15 N·m (128 lb in)	6.8 N·m (60 lb in)	10 N·m (89 lb in)
M8	18 N·m (163 lb in)	25 N·m (217 lb in)	26 N·m (234 lb in)	35 N·m (311 lb in)	17 N·m (151 lb in)	24 N·m (212 lb in)
M10	37 N·m (27 lb ft)	49 N·m (36 lb ft)	52 N·m (38 lb ft)	70 N·m (51 lb ft)	33 N·m (25 lb ft)	48 N·m (35 lb ft)
M12	64 N·m (47 lb ft)	85 N·m (63 lb ft)	91 N·m (67 lb ft)	121 N·m (90 lb ft)	58 N·m (43 lb ft)	83 N·m (61 lb ft)
M16	158 N·m (116 lb ft)	210 N·m (155 lb ft)	225 N·m (166 lb ft)	301 N·m (222 lb ft)	143 N·m (106 lb ft)	205 N·m (151 lb ft)
M20	319 N·m (235 lb ft)	425 N·m (313 lb ft)	440 N·m (325 lb ft)	587 N·m (433 lb ft)	290 N·m (214 lb ft)	400 N·m (295 lb ft)
M24	551 N·m (410 lb ft)	735 N·m (500 lb ft)	762 N·m (560 lb ft)	1016 N·m (750 lb ft)	501 N·m (370 lb ft)	693 N·m (510 lb ft)

NOTE: M4 through M8 hardware torque specifications are shown in pound-inches. M10 through M24 hardware torque specifications are shown in pound-feet.

METRIC FLANGED HARDWARE

NOM. SIZE	CLASS 8.8 BOLT and CLASS 8 NUT		CLASS 10.9 BOLT and CLASS 10 NUT		LOCKNUT CL.8 W/CL8.8 BOLT	LOCKNUT CL.10 W/CL10.9 BOLT
	UNPLATED	PLATED W/ZnCr	UNPLATED	PLATED W/ZnCr		
M4	2.4 N·m (21 lb in)	3.2 N·m (28 lb in)	3.5 N·m (31 lb in)	4.6 N·m (41 lb in)	2.2 N·m (19 lb in)	3.1 N·m (27 lb in)
M5	4.9 N·m (43 lb in)	6.5 N·m (58 lb in)	7.0 N·m (62 lb in)	9.4 N·m (83 lb in)	4.4 N·m (39 lb in)	6.4 N·m (57 lb in)
M6	8.3 N·m (73 lb in)	11 N·m (96 lb in)	12 N·m (105 lb in)	16 N·m (141 lb in)	7.5 N·m (66 lb in)	11 N·m (96 lb in)
M8	20 N·m (179 lb in)	27 N·m (240 lb in)	29 N·m (257 lb in)	39 N·m (343 lb in)	18 N·m (163 lb in)	27 N·m (240 lb in)
M10	40 N·m (30 lb ft)	54 N·m (40 lb ft)	57 N·m (42 lb ft)	77 N·m (56 lb ft)	37 N·m (27 lb ft)	53 N·m (39 lb ft)
M12	70 N·m (52 lb ft)	93 N·m (69 lb ft)	100 N·m (74 lb ft)	134 N·m (98 lb ft)	63 N·m (47 lb ft)	91 N·m (67 lb ft)
M16	174 N·m (128 lb ft)	231 N·m (171 lb ft)	248 N·m (183 lb ft)	331 N·m (244 lb ft)	158 N·m (116 lb ft)	226 N·m (167 lb ft)
M20	350 N·m (259 lb ft)	467 N·m (345 lb ft)	484 N·m (357 lb ft)	645 N·m (476 lb ft)	318 N·m (235 lb ft)	440 N·m (325 lb ft)
M24	607 N·m (447 lb ft)	809 N·m (597 lb ft)	838 N·m (618 lb ft)	1118 N·m (824 lb ft)	552 N·m (407 lb ft)	

IDENTIFICATION

Metric Hex head and carriage bolts, classes 5.6 and up

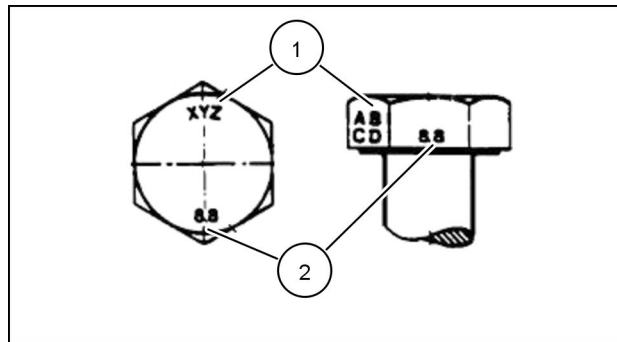

20083680 1

1. Manufacturer's Identification
2. Property Class

Metric Hex nuts and locknuts, classes 05 and up

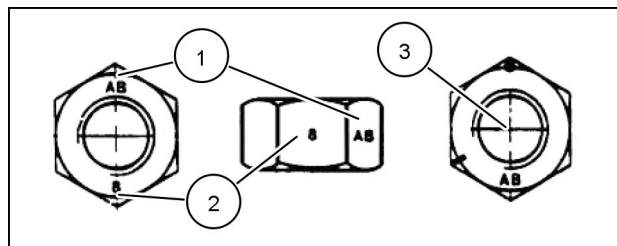

20083681 2

INTRODUCTION

1. Manufacturer's Identification
2. Property Class
3. Clock Marking of Property Class and Manufacturer's Identification (Optional), i.e. marks **60 °** apart indicate Class 10 properties, and marks **120 °** apart indicate Class 8.

INCH NON-FLANGED HARDWARE

NOMINAL SIZE	SAE GRADE 5 BOLT and NUT		SAE GRADE 8 BOLT and NUT		LOCKNUT GrB W/ Gr5 BOLT	LOCKNUT GrC W/ Gr8 BOLT
	UN-PLATED or PLATED SILVER	PLATED W/ZnCr GOLD	UN-PLATED or PLATED SILVER	PLATED W/ZnCr GOLD		
1/4	8 N·m (71 lb in)	11 N·m (97 lb in)	12 N·m (106 lb in)	16 N·m (142 lb in)	8.5 N·m (75 lb in)	12.2 N·m (109 lb in)
5/16	17 N·m (150 lb in)	23 N·m (204 lb in)	24 N·m (212 lb in)	32 N·m (283 lb in)	17.5 N·m (155 lb in)	25 N·m (220 lb in)
3/8	30 N·m (22 lb ft)	40 N·m (30 lb ft)	43 N·m (31 lb ft)	57 N·m (42 lb ft)	31 N·m (23 lb ft)	44 N·m (33 lb ft)
7/16	48 N·m (36 lb ft)	65 N·m (48 lb ft)	68 N·m (50 lb ft)	91 N·m (67 lb ft)	50 N·m (37 lb ft)	71 N·m (53 lb ft)
1/2	74 N·m (54 lb ft)	98 N·m (73 lb ft)	104 N·m (77 lb ft)	139 N·m (103 lb ft)	76 N·m (56 lb ft)	108 N·m (80 lb ft)
9/16	107 N·m (79 lb ft)	142 N·m (105 lb ft)	150 N·m (111 lb ft)	201 N·m (148 lb ft)	111 N·m (82 lb ft)	156 N·m (115 lb ft)
5/8	147 N·m (108 lb ft)	196 N·m (145 lb ft)	208 N·m (153 lb ft)	277 N·m (204 lb ft)	153 N·m (113 lb ft)	215 N·m (159 lb ft)
3/4	261 N·m (193 lb ft)	348 N·m (257 lb ft)	369 N·m (272 lb ft)	491 N·m (362 lb ft)	271 N·m (200 lb ft)	383 N·m (282 lb ft)
7/8	420 N·m (310 lb ft)	561 N·m (413 lb ft)	594 N·m (438 lb ft)	791 N·m (584 lb ft)	437 N·m (323 lb ft)	617 N·m (455 lb ft)
1	630 N·m (465 lb ft)	841 N·m (620 lb ft)	890 N·m (656 lb ft)	1187 N·m (875 lb ft)	654 N·m (483 lb ft)	924 N·m (681 lb ft)

NOTE: For Imperial Units, 1/4 in and 5/16 in hardware torque specifications are shown in pound-inches. 3/8 in through 1 in hardware torque specifications are shown in pound-feet.

INCH FLANGED HARDWARE

NOM- INAL SIZE	SAE GRADE 5 BOLT and NUT		SAE GRADE 8 BOLT and NUT		LOCKNUT GrF W/ Gr5 BOLT	LOCKNUT GrG W/ Gr8 BOLT
	UNPLATED or PLATED SILVER	PLATED W/ZnCr GOLD	UNPLATED or PLATED SILVER	PLATED W/ZnCr GOLD		
1/4	9 N·m (80 lb in)	12 N·m (106 lb in)	13 N·m (115 lb in)	17 N·m (150 lb in)	8 N·m (71 lb in)	12 N·m (106 lb in)
5/16	19 N·m (168 lb in)	25 N·m (221 lb in)	26 N·m (230 lb in)	35 N·m (310 lb in)	17 N·m (150 lb in)	24 N·m (212 lb in)
3/8	33 N·m (25 lb ft)	44 N·m (33 lb ft)	47 N·m (35 lb ft)	63 N·m (46 lb ft)	30 N·m (22 lb ft)	43 N·m (32 lb ft)
7/16	53 N·m (39 lb ft)	71 N·m (52 lb ft)	75 N·m (55 lb ft)	100 N·m (74 lb ft)	48 N·m (35 lb ft)	68 N·m (50 lb ft)
1/2	81 N·m (60 lb ft)	108 N·m (80 lb ft)	115 N·m (85 lb ft)	153 N·m (113 lb ft)	74 N·m (55 lb ft)	104 N·m (77 lb ft)
9/16	117 N·m (86 lb ft)	156 N·m (115 lb ft)	165 N·m (122 lb ft)	221 N·m (163 lb ft)	106 N·m (78 lb ft)	157 N·m (116 lb ft)
5/8	162 N·m (119 lb ft)	216 N·m (159 lb ft)	228 N·m (168 lb ft)	304 N·m (225 lb ft)	147 N·m (108 lb ft)	207 N·m (153 lb ft)
3/4	287 N·m (212 lb ft)	383 N·m (282 lb ft)	405 N·m (299 lb ft)	541 N·m (399 lb ft)	261 N·m (193 lb ft)	369 N·m (272 lb ft)
7/8	462 N·m (341 lb ft)	617 N·m (455 lb ft)	653 N·m (482 lb ft)	871 N·m (642 lb ft)	421 N·m (311 lb ft)	594 N·m (438 lb ft)
1	693 N·m (512 lb ft)	925 N·m (682 lb ft)	979 N·m (722 lb ft)	1305 N·m (963 lb ft)	631 N·m (465 lb ft)	890 N·m (656 lb ft)

IDENTIFICATION

Inch Bolts and free-spinning nuts

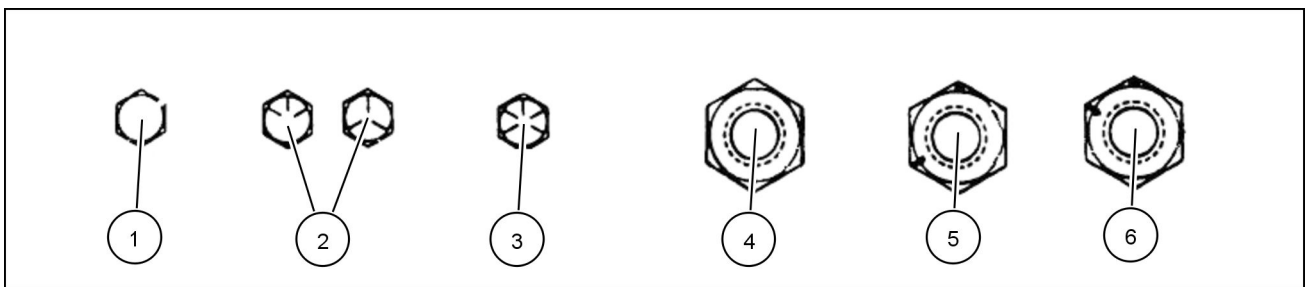

20083682 3

Grade Marking Examples

SAE Grade Identification			
1	Grade 2 - No Marks	4	Grade 2 Nut - No Marks
2	Grade 5 - Three Marks	5	Grade 5 Nut - Marks 120 ° Apart
3	Grade 8 - Five Marks	6	Grade 8 Nut - Marks 60 ° Apart

Inch Lock Nuts, All Metal (Three optional methods)

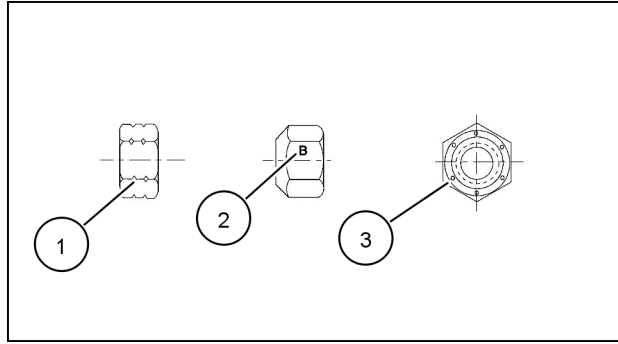

20090268 4

Grade Identification

Grade	Corner Marking Method (1)	Flats Marking Method (2)	Clock Marking Method (3)
Grade A	No Notches	No Mark	No Marks
Grade B	One Circumferential Notch	Letter B	Three Marks
Grade C	Two Circumferential Notches	Letter C	Six Marks



Torque - Standard torque data for hydraulics

INSTALLATION OF ADJUSTABLE FITTINGS IN STRAIGHT THREAD O RING BOSSES

1. Lubricate the O-ring by coating it with a light oil or petroleum. Install the O-ring in the groove adjacent to the metal backup washer which is assembled at the extreme end of the groove (4).
2. Install the fitting into the SAE straight thread boss until the metal backup washer contacts the face of the boss (5).

NOTE: Do not over tighten and distort the metal backup washer.

3. Position the fitting by turning out (counterclockwise) up to a maximum of one turn. Holding the pad of the fitting with a wrench, tighten the locknut and washer against the face of the boss (6).

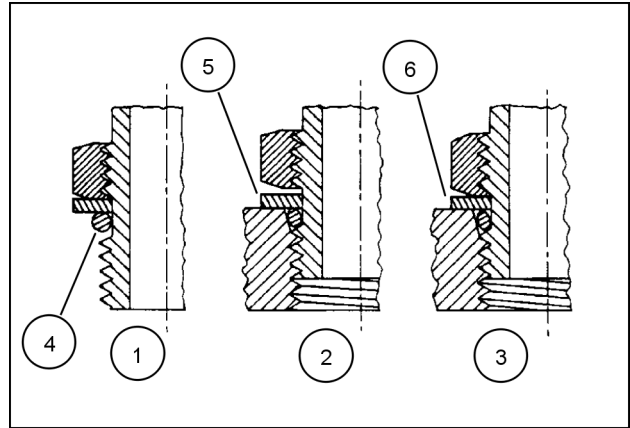

23085659 1

STANDARD TORQUE DATA FOR HYDRAULIC TUBES AND FITTINGS

TUBE NUTS FOR 37° FLARED FITTINGS				O-RING BOSS PLUGS ADJUSTABLE FITTING LOCKNUTS, SWIVEL JIC- 37° SEATS
SIZE	TUBING OD	THREAD SIZE	TORQUE	TORQUE
4	6.4 mm (1/4 in)	7/16-20	12 - 16 N·m (9 - 12 lb ft)	8 - 14 N·m (6 - 10 lb ft)
5	7.9 mm (5/16 in)	1/2-20	16 - 20 N·m (12 - 15 lb ft)	14 - 20 N·m (10 - 15 lb ft)
6	9.5 mm (3/8 in)	9/16-18	29 - 33 N·m (21 - 24 lb ft)	20 - 27 N·m (15 - 20 lb ft)
8	12.7 mm (1/2 in)	3/4-16	47 - 54 N·m (35 - 40 lb ft)	34 - 41 N·m (25 - 30 lb ft)
10	15.9 mm (5/8 in)	7/8-14	72 - 79 N·m (53 - 58 lb ft)	47 - 54 N·m (35 - 40 lb ft)
12	19.1 mm (3/4 in)	1-1/16-12	104 - 111 N·m (77 - 82 lb ft)	81 - 95 N·m (60 - 70 lb ft)
14	22.2 mm (7/8 in)	1-3/16-12	122 - 136 N·m (90 - 100 lb ft)	95 - 109 N·m (70 - 80 lb ft)
16	25.4 mm (1 in)	1-5/16-12	149 - 163 N·m (110 - 120 lb ft)	108 - 122 N·m (80 - 90 lb ft)
20	31.8 mm (1-1/4 in)	1-5/8-12	190 - 204 N·m (140 - 150 lb ft)	129 - 158 N·m (95 - 115 lb ft)
24	38.1 mm (1-1/2 in)	1-7/8-12	217 - 237 N·m (160 - 175 lb ft)	163 - 190 N·m (120 - 140 lb ft)
32	50.8 mm (2 in)	2-1/2-12	305 - 325 N·m (225 - 240 lb ft)	339 - 407 N·m (250 - 300 lb ft)

These torques are not recommended for tubes of 12.7 mm (1/2 in) OD and larger with wall thickness of 0.889 mm (0.035 in) or less. The torque is specified for 0.889 mm (0.035 in) wall tubes on each application individually.

Before installing and torquing 37 ° flared fittings, clean the face of the flare and threads with a clean solvent or Loctite cleaner and apply hydraulic sealant **LOCTITE® 569** to the 37 ° flare and the threads.

Install fitting and torque to specified torque, loosen fitting and retorque to specifications.

PIPE THREAD FITTING TORQUE

Before installing and tightening pipe fittings, clean the threads with a clean solvent or Loctite cleaner and apply sealant **LOCTITE® 567 PST PIPE SEALANT** for all fittings including stainless steel or **LOCTITE® 565 PST** for most metal fittings. For high filtration/zero contamination systems use **LOCTITE® 545**.

PIPE THREAD FITTING	
Thread Size	Torque (Maximum)
1/8-27	13 N·m (10 lb ft)
1/4-18	16 N·m (12 lb ft)
3/8-18	22 N·m (16 lb ft)
1/2-14	41 N·m (30 lb ft)
3/4-14	54 N·m (40 lb ft)

INSTALLATION OF ORFS (O-RING FLAT FACED) FITTINGS

When installing ORFS fittings thoroughly clean both flat surfaces of the fittings **(1)** and lubricate the O-ring **(2)** with light oil. Make sure both surfaces are aligned properly. Torque the fitting to specified torque listed throughout the repair manual.

NOTICE: If the fitting surfaces are not properly cleaned, the O-ring will not seal properly. If the fitting surfaces are not properly aligned, the fittings may be damaged and will not seal properly.

NOTICE: Always use genuine factory replacement oils and filters to ensure proper lubrication and filtration of engine and hydraulic system oils.

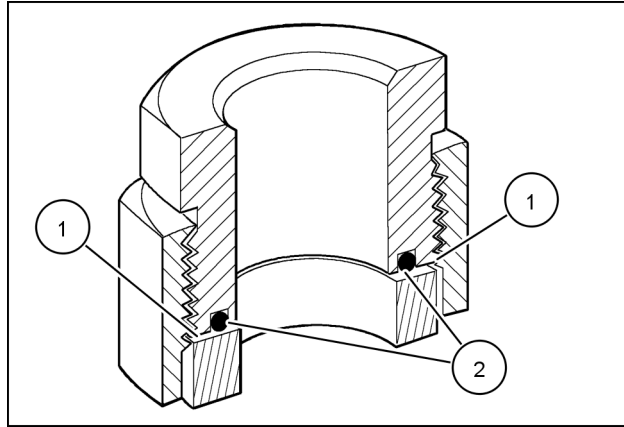

50011183 2

The use of proper oils, grease, and keeping the hydraulic system clean will extend machine and component life.

General specification - Biodiesel Fuels

Fatty Acid Methyl Ester Biodiesel (Biodiesel Fuel) consists of a family of fuels derived from vegetable oils treated with methyl esters.

NOTICE: Biodiesel Fuel blends are approved for your engine only if they comply with **EN14214** Specification Standards or **ASTM D6751**.

NOTICE: It is imperative that you check which blend is approved for your engine with your CaseIH dealer. Be aware that the use of Biodiesel Fuel that does not comply with the Standards mentioned above could lead to severe damage to the engine and fuel system of your machine. The use of fuels that are not approved may void CASE IH AGRICULTURE Warranty coverage.

Biodiesel Fuel Usage Conditions

NOTICE: The Biodiesel Fuel must meet the fuel Specification mentioned above.

Biodiesel Fuel must be purchased from a trusted supplier that understands the product and maintains good fuel quality. Biodiesel Fuel must be pre-blended by the supplier. Mixing Biodiesel Fuels on-site can result incorrect mixture that can lead to problems with both engine and fuel system.

Engine performance is affected by the use of Biodiesel Fuel. There may be up to **12 %** reduction in power or torque depending on the blend used.

NOTICE: DO NOT modify the engine and/or injection pump settings to recover the reduced performance.

The reduced power must be accepted if using any Biodiesel Fuel blend.

Some modification may be required to allow your engine to run Biodiesel Fuel. Consult you dealer for complete information on these modifications.

Biodiesel Fuel has a higher cloud point than Diesel Fuel.

NOTICE: ~~The use of high Biodiesel Fuel blends are not recommended in cold weather conditions.~~

With Biodiesel Fuels, it may be necessary to change the engine oil, engine oil filter and fuel filter elements more frequently than with Diesel Fuels. Biodiesel Fuel can remove rust and particles from the inside of on-site fuel storage tanks that would normally adhere to the sides of the tank. Like particle deposits that commonly occur with Diesel Fuel, these particles can become trapped by the machine fuel filters, causing blockage and shortening filter life. In cold weather, this is more likely to happen. Consult your CaseIH dealer for information on cold weather operation and proper maintenance intervals when using any Biodiesel Fuel blend.

When handling Biodiesel Fuel, care must be taken not to allow water into the fuel supply. Biodiesel Fuel will actually attract moisture from the atmosphere.

Fuel tanks must be kept as full as possible to limit the amount of air and water vapors in them. It may be necessary to drain the fuel filter water tap more frequently.

Potential oxidation and stability could be a problem with the fuel stored in the machine.

NOTICE: Machines must not be stored for more than three months with Biodiesel Fuel blends in the fuel system.

If long storage periods are necessary, the engine must run on Diesel Fuel for 20 hours to flush the Biodiesel Fuel out of the engine fuel system prior to storage.

NOTICE: Biodiesel Fuel must not be stored in on-site storage tanks for more than three months.

Any spillage of Biodiesel Fuel must be cleaned up immediately before it can cause damage to the environment and the paint finish of the machine.

Before using Biodiesel Fuel blends you should consult with your dealer to receive full information about the approved blend for your machine and any detailed conditions of its usage.

NOTICE: Be aware that not fulfilling the requirements and conditions of Biodiesel Fuel usage will void your machine's CaseIH Warranty coverage.

CONSUMABLES INDEX

Consumable	IU	PAGE
Loctite® 569	Torque - Standard torque data for hydraulics	15
Loctite® 567 PST Pipe Sealant	Torque - Standard torque data for hydraulics	16
Loctite® 565 PST	Torque - Standard torque data for hydraulics	16
Loctite® 545	Torque - Standard torque data for hydraulics	16





SERVICE MANUAL

HYDRAULIC, PNEUMATIC, ELECTRICAL, ELECTRONIC SYSTEMS



PUMA 170 CVT , PUMA 170 , PUMA 185 CVT , PUMA 185 , PUMA 200 CVT ,
PUMA 200 , PUMA 215 CVT , PUMA 215 , PUMA 230 CVT

Contents

HYDRAULIC, PNEUMATIC, ELECTRICAL, ELECTRONIC SYSTEMS - A

PRIMARY HYDRAULIC POWER SYSTEM.....	A.10.A
PUMA 170 CVT , PUMA 170 , PUMA 185 CVT , PUMA 185 , PUMA 200 CVT , PUMA 200 , PUMA 215 CVT , PUMA 215 , PUMA 230 CVT	
PRIMARY HYDRAULIC POWER SYSTEM Closed center mechanical remote valve	A.10.B
PUMA 170 CVT , PUMA 170 , PUMA 185 CVT , PUMA 185 , PUMA 200 CVT , PUMA 200 , PUMA 215 CVT , PUMA 215 , PUMA 230 CVT	
PRIMARY HYDRAULIC POWER SYSTEM Electro-hydraulic remote valve	A.10.C
PUMA 170 CVT , PUMA 170 , PUMA 185 CVT , PUMA 185 , PUMA 200 CVT , PUMA 200 , PUMA 215 CVT , PUMA 215 , PUMA 230 CVT	
SECONDARY HYDRAULIC POWER SYSTEM.....	A.12.A
PUMA 170 CVT , PUMA 170 , PUMA 185 CVT , PUMA 185 , PUMA 200 CVT , PUMA 200 , PUMA 215 CVT , PUMA 215 , PUMA 230 CVT	
HYDRAULIC COMMAND SYSTEM.....	A.14.A
PUMA 170 CVT , PUMA 170 , PUMA 185 CVT , PUMA 185 , PUMA 200 CVT , PUMA 200 , PUMA 215 CVT , PUMA 215 , PUMA 230 CVT	
PNEUMATIC SYSTEM.....	A.20.A
PUMA 170 CVT , PUMA 170 , PUMA 185 CVT , PUMA 185 , PUMA 200 CVT , PUMA 200 , PUMA 215 CVT , PUMA 215 , PUMA 230 CVT	
ELECTRICAL POWER SYSTEM	A.30.A
PUMA 170 CVT , PUMA 170 , PUMA 185 CVT , PUMA 185 , PUMA 200 CVT , PUMA 200 , PUMA 215 CVT , PUMA 215 , PUMA 230 CVT	
ELECTRONIC SYSTEM	A.50.A
PUMA 170 CVT , PUMA 170 , PUMA 185 CVT , PUMA 185 , PUMA 200 CVT , PUMA 200 , PUMA 215 CVT , PUMA 215 , PUMA 230 CVT	
FAULT CODES	A.50.A
PUMA 170 CVT , PUMA 170 , PUMA 185 CVT , PUMA 185 , PUMA 200 CVT , PUMA 200 , PUMA 215 CVT , PUMA 215 , PUMA 230 CVT	