

570MXT Loader Landscaper

Service Manual 6-43571

Table of Contents

Description	Section No.	Publication Form No.
General	Tab 1	
Section Index - General		6-43590
Standard Torque Specifications	1001	7-52931
Fluids and Lubricants	1002	6-43460
Metric Conversion Chart	1003	7-52950
Loctite Product Chart		8-98902
Engine	Tab 2	
Section Index - Engine		6-43600
Engine and Radiator Removal and Installation	2000	6-43820
Stall Tests	2002	6-43470
For Engine Repair, see the Engine Service Manual.		
Fuel System	Tab 3	
For Fuel System Repair, see the Engine Service Manual.		
Electrical	Tab 4	
Section Index - Electrical		6-43610
Removal and Installation of Electrical Components	4000	6-41930
Electrical Specifications and Troubleshooting	4001	6-43480
Batteries	4003	7-49440
Starter Motor - Denso	4004	7-11451
Instrument Cluster	4005	6-41880
Alternator	4007	7-49250
Steering	Tab 5	
Section Index - Steering		6-43620
Removal and Installation of Steering Components	5000	6-41950
Steering Specifications, Pressure Checks and Troubleshooting	5001	6-43490
Steering Control Valve	5002	7-11920
Steering Cylinders	5003	7-11930
Front Axle - Two Wheel Drive	5005	7-10470
Front Axle - Four Wheel Drive	5006	6-43840

Reprinted

Table of Contents

Description	Section No.	Publication Form No.
Power Train		
	Tab 6	
Section Index - Power Train		6-43630
Removal and Installation of Power Train Components	6000	6-43850
Standard (Carraro) Transmission Specifications, Pressure Checks and Troubleshooting	6002	6-40700
Wheels and Tires	6003	6-43860
Rear Axle and Planetaries	6004	6-43870
Standard (Carraro) Transmission	6007	6-41730
Brakes		
	Tab 7	
Section Index - Brakes		6-43640
Removal and Installation of Brake Components	7000	6-42040
Master Cylinder	7003	7-49490
For parking brake and brake pedal adjustments, see Section 9001.		
Hydraulics		
	Tab 8	
Section Index - Hydraulics		6-43650
Removal and Installation of Hydraulic Components	8001	6-43881
Hydraulic Specifications, Troubleshooting, and Pressure Checks	8002	6-43511
Cleaning the Hydraulic System	8003	7-49640
Hydraulic Pump	8004	7-14761
Loader Control Valve	8005	7-11223
Cylinders	8006	7-50880
Three Point Hitch Control Valve	8007	6-43670
Accumulator for Machines with Optional Ride Control	8009	7-52450
Solenoid Valve for Machines with Optional Ride Control	8010	7-14561
Flow Control Valve	8011	6-43890
Lock Valve	8012	6-43900
Flow Control Priority Valve	8013	6-76990
Mounted Equipment		
	Tab 9	
Section Index - Mounted Equipment		6-43660
Pedals and Levers	9001	6-43520
Air Conditioning Troubleshooting For Systems With R-134a Refrigerant	9002	7-50091
Air Conditioning System Gauges and Testing For Systems With R-134a Refrigerant	9003	7-50901
Air Conditioning System Service For Systems With R-134a Refrigerant	9004	7-51030
Air Conditioning Components Service For Systems With R-134a Refrigerant	9005	7-51050
Loader	9006	6-42110
ROPS Cab and Canopy	9007	7-14800
Standard and Mechanical Suspension Seat	9009	6-42140
Schematics		
Electric and Hydraulic Schematic Foldout P.I.N. JJG0301854 and Before	In Rear Pocket	6-43530
Electric and Hydraulic Schematic Foldout P.I.N. JJG0301855 and After	In Rear Pocket	6-77010

NOTE: Case Corporation reserves the right to make improvements in design or changes in specifications at any time without incurring any obligation to install them on units previously sold.

SECTION INDEX

GENERAL

Section Title	Section Number
Standard Torque Specifications	1001
Fluid and Lubricants	1002
Metric Conversion Chart	1003
Loctite Product Chart	

CASE CORPORATION
700 State Street
Racine, WI 53404 U.S.A.

CASE CANADA CORPORATION
3350 South Service Road
Burlington, ON L7N 3M6 CANADA

Bur 6-43590

Copyright © 2001 Case Corporation
Printed in U.S.A.
July, 2001

Section 1001

STANDARD TORQUE SPECIFICATIONS

CASE CORPORATION
700 State Street
Racine, WI 53404 U.S.A.

CASE CANADA CORPORATION
450 Sherman Avenue
Hamilton, ON L8N 4C4 CANADA

Bur 7-52931

© 1998 Case Corporation
Printed in U.S.A.
September, 1998

TABLE OF CONTENTS

TORQUE SPECIFICATIONS - DECIMAL HARDWARE	3
Grade 5 Bolts, Nuts, and Studs	3
Grade 8 Bolts, Nuts, and Studs	3
TORQUE SPECIFICATIONS - METRIC HARDWARE	4
Grade 8.8 Bolts, Nuts, and Studs	4
Grade 12.9 Bolts, Nuts, and Studs	4
Grade 10.9 Bolts, Nuts, and Studs	4
TORQUE SPECIFICATIONS - STEEL HYDRAULIC FITTINGS	5
37 Degree Flare Fitting	5
Straight Threads with O-ring	5
Split Flange Mounting Bolts	6
O-Ring Face Seal End	6
O-Ring Boss End	6
Fitting or Lock Nut	6
Pipe fittings	7

TORQUE SPECIFICATIONS - DECIMAL HARDWARE

Use the torques in this chart when special torques are not given. These torques apply to fasteners with both UNC and UNF threads as received from suppliers dry, or when lubricated with engine oil. Not applicable if special graphities, Molydisulfide greases, or other extreme pressure lubricants are used.

Grade 5 Bolts, Nuts, and Studs		
		
Size	Newton metres	Pound-Inches
1/4 inch	10 to 12	91 to 103
5/16 inch	21 to 24	188 to 212
3/8 inch	38 to 43	336 to 378
		Pound-Feet
7/16 inch	61 to 69	45 to 51
1/2 inch	94 to 104	68 to 76
9/16 inch	132 to 149	98 to 110
5/8 inch	183 to 210	138 to 155
3/4 inch	325 to 370	242 to 270
7/8 inch	530 to 595	390 to 435
1.0 inch	790 to 890	585 to 655
1-1/8 inch	980 to 1100	725 to 805
1-1/4 inch	1385 to 1555	1020 to 1145
1-3/8 inch	1810 to 2030	1335 to 1495
1-1/2 inch	2400 to 2700	1770 to 1990

Grade 8 Bolts, Nuts, and Studs		
		
Size	Newton metres	Pound-Inches
1/4 inch	15 to 16	130 to 145
5/16 inch	30 to 34	268 to 301
3/8 inch	54 to 60	474 to 534
		Pound-Feet
7/16 inch	86 to 97	63 to 71
1/2 inch	132 to 149	96 to 110
9/16 inch	191 to 213	140 to 155
5/8 inch	260 to 293	190 to 215
3/4 inch	480 to 515	340 to 380
7/8 inch	745 to 835	550 to 615
1.0 inch	1120 to 1280	825 to 925
1-1/8 inch	1585 to 1785	1170 to 1315
1-1/4 inch	2215 to 2235	1650 to 1855
1-3/8 inch	2930 to 3295	2160 to 2430
1-1/2 inch	3895 to 4375	2870 to 3225

NOTE: Use thick nuts with Grade 8 bolts.

TORQUE SPECIFICATIONS - METRIC HARDWARE

Use the following torques when specifications are not given.

These values apply to fasteners with both coarse and fine threads as received from supplier, plated or unplated, or when lubricated with engine oil. These values do not apply if graphite or Molydisulfide grease or oil is used. Use of a click type torque wrench, or better is required.

Grade 8.8 Bolts, Nuts, and Studs		
		
Size	Newton metres	Pound-Inches
M4	3 to 4	31 to 35
M5	5 to 6	49 to 55
M6	10 to 11	84 to 94
M8	23 to 26	229 to 277
M10	46 to 51	408 to 460
		Pound-Feet
M12	80 to 90	59 to 66
M14	128 to 145	94 to 106
M16	200 to 220	149 to 161
M20	400 to 450	293 to 330
M24	690 to 780	510 to 575
M30	1375 to 1545	1010 to 1140
M36	2400 to 2700	1770 to 1990

Grade 10.9 Bolts, Nuts, and Studs		
		
Size	Newton metres	Pound-Inches
M4	5 to 6	44 to 49
M5	8 to 9	71 to 79
M6	14 to 15	120 to 136
M8	33 to 37	293 to 329
		Pound-Feet
M10	65 to 74	48 to 54
M12	114 to 128	85 to 94
M14	183 to 205	136 to 153
M16	285 to 320	208 to 235
M20	555 to 620	406 to 460
M24	955 to 1075	705 to 790
M30	1900 to 2140	1400 to 1580
M36	3315 to 3730	2445 to 2750

Grade 12.9 Bolts, Nuts, and Studs



Usually the torque values specified for grade 10.9 fasteners can be used satisfactorily on grade 12.9 fasteners.

TORQUE SPECIFICATIONS - STEEL HYDRAULIC FITTINGS

37 Degree Flare Fitting				
Nom. SAE Dash Size	Tube OD/Hose ID	Thread Size	Newton metres	Pound-Inches
-2		5/16 - 24	8 to 9	72 to 84
-3		3/8 - 24	11 to 12	96 to 108
-4	6.4 mm (1/4 inch)	7/16 - 20	14 to 16	120 to 144
-5	7.9 mm (5/16 inch)	1/2 - 20	18 to 21	156 to 192
-6	9.5 mm (3/8 inch)	9/16 - 18	27 to 33	240 to 300
-8	12.7 mm (1/2 inch)	3/4 - 16	46 to 56	408 to 504
-10	15.9 mm (5/8 inch)	7/8 - 14	77 to 85	684 to 756
				Pound-Feet
-12	19.0 mm (3/4 inch)	1-1/16 - 12	107 to 119	79 to 88
-14	22.2 mm (7/8 inch)	1-3/16 - 12	127 to 140	94 to 103
-16	25.4 mm (1.0 inch)	1-5/16 - 12	131 to 156	97 to 117
-20	31.8 mm (1-1/4 inch)	1-5/8 - 12	197 to 223	145 to 165
-24	38.1 mm (1-1/2 inch)	1-7/8 - 12	312 to 338	230 to 250

Straight Threads with O-ring				
Nom. SAE Dash Size	Tube OD/Hose ID	Thread Size	Newton metres	Pound-Inches
-2		5/16 - 24	8 to 9	72 to 84
-3		3/8 - 24	11 to 12	96 to 108
-4	6.4 mm (1/4 inch)	7/16-20	20 to 25	180 to 228
-5	7.9 mm (5/16 inch)	1/2-20	27 to 33	240 to 300
-6	9.5 mm (3/8 inch)	9/16-18	43 to 54	384 to 480
-8	12.7 mm (1/2 inch)	3/4-16	73 to 90	648 to 804
				Pound-Feet
-10	15.9 mm (5/8 inch)	7/8-14	100 to 124	74 to 92
-12	19.0 mm (3/4 inch)	1-1/16-12	138 to 173	102 to 128
-14	22.2 mm (7/8 inch)	1-3/16-12	173 to 216	128 to 160
-16	25.4 mm (1.0 inch)	1-5/16-12	203 to 253	150 to 187
-20	31.8 mm (1-1/4 inch)	1-5/8-12	308 to 357	227 to 264
-24	38.1 mm (1-1/2 inch)	1-7/8-12	492 to 542	363 to 400

Split Flange Mounting Bolts		
Size	Newton metres	Pound-Inches
5/16-18	20 to 27	180 to 240
3/8-16	27 to 34	240 to 300
7/16-14	47 to 61	420 to 540
		Pound-Feet
1/2-13	74 to 88	55 to 65
5/8-11	190 to 203	140 to 150

O-Ring Face Seal End					O-Ring Boss End Fitting or Lock Nut		
Nom. SAE Dash Size	Tube OD	Thread Size	Newton metres	Pound-Inches	Thread Size	Newton metres	Pound-Inches
-4	6.4 mm (1/4 inch)	9/16-18	23 to 26	204 to 228			
-6	9.5 mm (3/8 inch)	11/16-16	34 to 40	300 to 348	9/16-18	48 to 54	432 to 480
-8	12.7 mm (1/2 inch)	13/16-16	52 to 57	456 to 504	3/4-16	70 to 78	612 to 684
							Pound-Feet
-10	15.9 mm (5/8 inch)	1-14	81 to 90	720 to 792	7/8-14	102 to 114	75 to 84
				Pound-Feet			
-12	19.0 mm (3/4 inch)	1-3/16-12	117 to 128	86 to 94	1-1/16-12	142 to 160	105 to 117
-16	25.4 mm (1.0 inch)	1-7/16-12	152 to 174	112 to 128	1-5/16-12	237 to 254	175 to 187
-20	31.8 mm (1-1/4 inch)	1-11/16-12	179 to 201	132 to 148			
-24	38.1 mm (1-1/2 inch)	2-12	213 to 235	157 to 173			

Pipe fittings		
Nom. SAE Dash Size	Thread Size	TFFT (Turns For Finger Tight)
-2	1/8 - 27	2.0 - 3.0
-3	1/8 - 27	2.0 - 3.0
-4	1/8 - 27	2.0 - 3.0
-5	1/8 - 27	2.0 - 3.0
-6	1/4 - 18	1.5 - 3.0
-8	3/8 - 18	2.0 - 3.0
-10	1/2 - 14	2.0 - 3.0
-12	3/4 - 14	2.0 - 3.0
-14	3/4 - 14	2.0 - 3.0
-16	1 - 11 1/2	1.5 - 2.5
-20	1 1/4 - 11 1/2	1.5 - 2.5
-24	1 1/2 - 11 1/2	1.5 - 2.5
-32	2 - 11 1/2	1.5 - 2.5

NOTE: Apply sealant/lubricant to male pipe threads. The first two threads should be left uncovered to avoid system contamination. Screw pipe fitting into female pipe port to the finger tight position. Wrench tighten fitting to the appropriate turns from finger tight (TFFT) shown in table above, making sure the tube end of an elbow or tee fitting is aligned to receive incoming tube or hose fitting.

Section 1002

FLUID AND LUBRICANTS

CASE CORPORATION
700 State Street
Racine, WI 53404 U.S.A.

CASE CANADA CORPORATION
3350 South Service Road
Burlington, ON L7N 3M6 CANADA

Bur 6-43460

Copyright © 2001 Case Corporation
Printed in U.S.A.
May, 2001

TABLE OF CONTENTS

CAPACITIES AND LUBRICANTS	3
ENGINE OIL RECOMMENDATIONS	4
DIESEL FUEL	5
Fuel Storage	5
Specifications for Acceptable No. 2 Diesel Fuel	5

CAPACITIES AND LUBRICANTS

Engine Crankcase	
Capacity with filter change	11 litres (11.6 U.S. quarts)
Specifications	Case No. 1 15W-40 API CG-4 or CF-4
Fuel Tank	
Capacity, usable	117 litres (31.0 U.S. gallons)
Optional tank	151 litres (40 U.S. gallons) usable
Specifications	See page 5
Cooling System	
Capacity with heater	16.5 litres (17.4 U.S. quarts)
Capacity without heater	15.8 litres (16.7 U.S. quarts)
Specifications	50% water and 50% ethylene glycol
Hydraulic System	
Total System.....	77 litres (20.3 U.S. gallons)
Capacity with filter change	55 litres (14.5 U.S. gallons)
Capacity without filter change	53 litres (14 U.S. gallons)
Specifications	MS-1209, Hy-Tran [®] Ultra
Transmission	
Standard Transmission	
2 Wheel Drive	
Total system capacity	18.5 litres (19.5 U.S. quarts)
Refill capacity with or without filter change	11.9 litres (12.6 U.S. quarts)
Type of Fluid	MS-1209, Hy-Tran [®] Ultra
4 Wheel Drive	
Total system capacity	21.0 litres (22.2 U.S. quarts)
Refill capacity with or without filter change	14.4 litres (15.2 U.S. quarts)
Type of Fluid	MS-1209, Hy-Tran [®] Ultra
Front Drive Axle - 4 Wheel Drive	
Capacity - center bowl	5.5 litres (5.8 U.S. quarts)
Capacity - each wheel end	0.7 litres (0.75 U.S. quarts)
Type of Fluid.....	MS-1209, Hy-Tran [®] Ultra
Rear Axle	
Capacity - center bowl	14.0 litres (15 U.S. quarts)
Capacity - each wheel end	1.5 litres (1.6 U.S. quarts)
Type of Fluid.....	MS-1209, Hy-Tran [®] Ultra
Brake Master Cylinder	(Brake fluid supplied by hydraulic reservoir, see Hydraulic System.)

ENGINE OIL RECOMMENDATIONS

Case IH No.1 Engine Oil is recommended for use in your Case IH Engine. Case IH No.1 Engine Oil will lubricate your engine correctly under all operating conditions. If Case IH No. 1 Multi-Viscosity Engine Oil is not available, Case IH No. 1 Single Grade Engine Oil can be used.



RH99K130

If Case IH No.1 Multi-Viscosity or Single Grade Engine Oil is not available, use only oil meeting API engine oil service category CE.

See the chart below for recommended viscosity at ambient air temperature ranges.



BP97H064

NOTE: Do not put Performance Additives or other oil additive products in the engine crankcase. The oil intervals given in this manual are according to tests with Case IH lubricants.

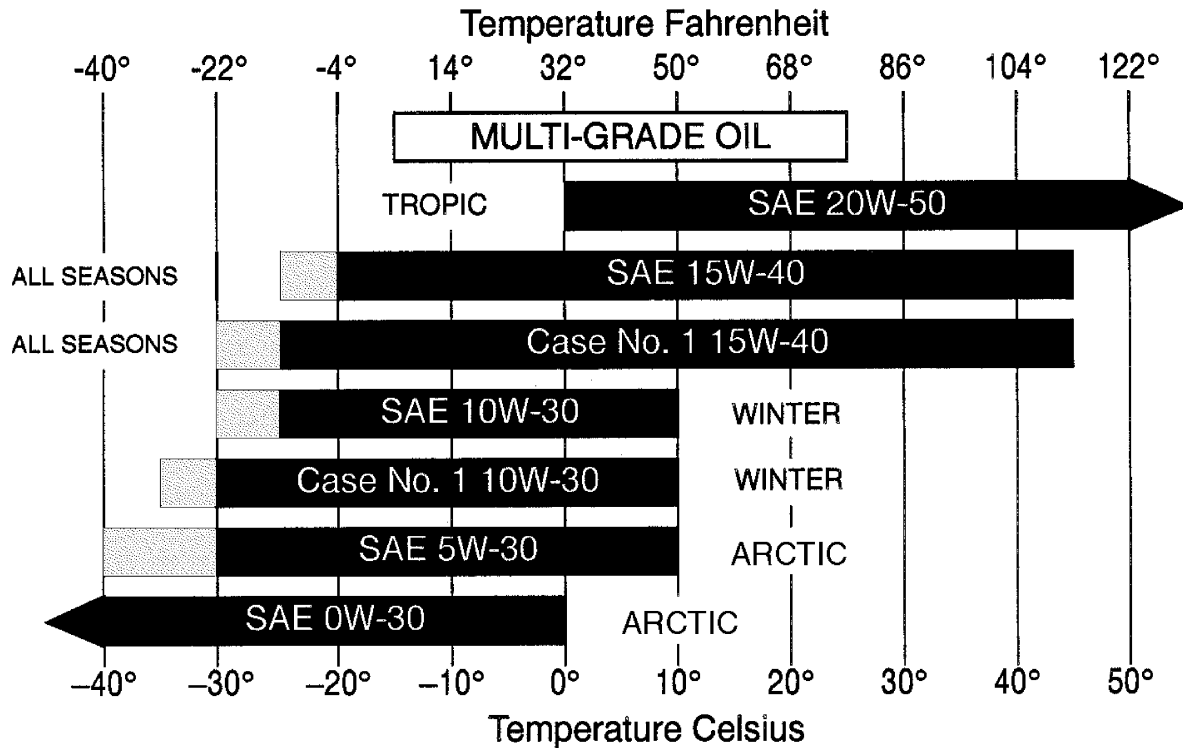

Indicates use of an engine oil heater or a jacket water heater is required.

BS99N019

DIESEL FUEL

Use No. 2 diesel fuel in the engine of this machine. The use of other fuels can cause the loss of engine power and high fuel consumption.

In very cold temperatures, a mixture of No. 1 and No. 2 diesel fuels is temporarily permitted. See the following Note.

NOTE: *See your fuel dealer for winter fuel requirements in your area. If the temperature of the fuel is below the cloud point (wax appearance point), wax crystals in the fuel will cause the engine to lose power or not start.*

The diesel fuel used in this machine must meet the specifications in the chart below or Specification D975-81 of the American Society for Testing and Materials.

Specifications for Acceptable No. 2 Diesel Fuel

API gravity, minimum	34
Flash Point, Minimum	60° C (140° F)
Cloud point (wax appearance point), maximum	-20° C (-5° F) See Note above
Pour point, maximum	-26° C (-15° F) See Note above
Viscosity, at 100° F (88° C)	
Centistokes	2.0 to 4.3
Saybolt Seconds Universal	32 to 40

Fuel Storage

If you keep fuel in storage for a period of time, you can get foreign material or water in the fuel storage tank. Many engine problems are caused by water in the fuel.

Keep the fuel storage tank outside and keep the fuel as cool as possible. Remove water from the storage container at regular periods of time.

NOTES

Section 1003

1003

METRIC CONVERSION CHART

TABLE OF CONTENTS

CONVERSION FACTORS	3
Metric to U.S.	3
U.S. to Metric	4

CONVERSION FACTORS Metric to U.S.

	<u>MULTIPLY</u>	<u>BY</u>	<u>TO OBTAIN</u>
Area:	sq. meter hectare	10.763 91 2.471 05	square foot acre
Force:	newton newton	3.596 942 0.224 809	ounce force pound force
Length:	millimeter meter kilometer	0.039 370 3.280 840 0.621 371	inch foot mile
Mass:	kilogram	2.204 622	pound
Mass/Area:	kilogram/hectare	0.000 466	ton/acre
Mass/Energy:	gr/kW/hr.	0.001 644	lbs/hp/hr.
Mass/Volume:	kg/cubic meter	1.685 555	lb/cubic yd.
Power:	kilowatt	1.341 02	horsepower
Pressure:	kilopascal bar	0.145 038 14.50385	lb/sq. inch lb/sq. inch
Temperature:	degree C	1.8 x C +32	degree F
Torque:	newton meter newton meter	8.850 748 0.737 562	lb/inch lb/foot
Velocity:	kilometer/hr.	0.621 371	miles/hr.
Volume:	cubic centimeter cubic meter cubic meter milliliter litre litre litre litre	0.061 024 35.314 66 1.307 950 0.033 814 1.056 814 0.879 877 0.264 172 0.219 969	cubic inch cubic foot cubic yd. ounce (US fluid) quart (US liquid) quart (Imperial) gallon (US liquid) gallon (Imperial)
Volume/Time:	litre/min. litre/min.	0.264 172 0.219 969	gallon/min. (US liquid) gallon/min. (Imperial)

U.S. to Metric

	<u>MULTIPLY</u>	<u>BY</u>	<u>TO OBTAIN</u>
Area:	square foot acre	0.092 903 0.404 686	square meter hectare
Force:	ounce force pound force	0.278 014 4.448 222	newton newton
Length:	inch foot mile	25.4 * 0.304 8 * 1.609 344 *	millimeter meter kilometer
Mass:	pound ounce	0.453 592 28.35	kilogram gram
Mass/Area:	ton/acre	2241 702	kilogram/hectare
Mass/Energy:	lb/hp/hr	608.277 4	gr/kW/hr
Mass/Volume:	lb/cubic yd.	0.593 276	kg/cubic meter
Power:	horsepower	0.745 700	kilowatt
Pressure:	lbs/sq. in. lbs/sq. in. lbs/sq. in.	6.894 757 0.069 0.070 303	kilopascal bar kg/sq. cm
Temperature:	degree F	1.8 F - 32	degree C
Torque:	pound/inch pound/foot	0.112 985 1.355 818	newton meter newton meter
Velocity:	miles/hr.	1.609 344 *	kilometer/hr.
Volume:	cubic inch cubic foot cubic yard ounce (US fluid) quart (US liquid) quart (Imperial) gallon (US) gallons (Imperial)	16.387 06 0.028 317 0.764.555 29.573 53 0.946 353 1.136 523 3.785 412 4.546 092	cubic centimeter cubic meter cubic meter milliliter litre litre litre litre
Volume/Time:	gallon/min.	3.785 412	litre/min.

* = exact

SECTION INDEX

ENGINES

Section Title	Section Number
Engine and Radiator Removal and Installation	2000
Stall Tests	2002
For Engine Repair, see the Engine Service Manual	

CASE CORPORATION
700 State Street
Racine, WI 53404 U.S.A.

CASE CANADA CORPORATION
3350 South Service Road
Burlington, ON L7N 3M6 CANADA

Bur 6-43600

Copyright © 2001 Case Corporation
Printed in U.S.A.
July, 2001

Section 2000

Engine and Radiator Removal and Installation

CASE CORPORATION
700 State Street
Racine, WI 53404 U.S.A.

CASE CANADA CORPORATION
3350 South Service Road
Burlington, ON L7N 3M6 CANADA

Bur 6-43820

Copyright © 2001 Case Corporation
Printed in U.S.A.
June, 2001

TABLE OF CONTENTS

SPECIAL TOOLS	2
RADIATOR REMOVAL	3
ENGINE REMOVAL	6
INSTALLING THE FRONT ENGINE SUPPORT	22

SPECIAL TOOLS



B430842

The CAS1690A is used to rotate the flywheel on the engine.

RADIATOR REMOVAL

Put identification tags on all disconnected hoses and wires. Close disconnected hoses and fittings with caps and plugs.

NOTE: *The photos in this procedure may be different from your machine and are for reference only.*

STEP 1

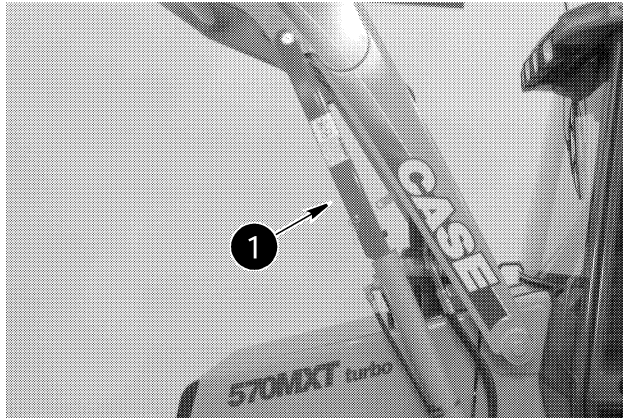

BD01D042

Park the machine on a level surface. Raise the loader and lock the support strut (1) to hold the loader. Stop the engine and apply the parking brake.

STEP 2

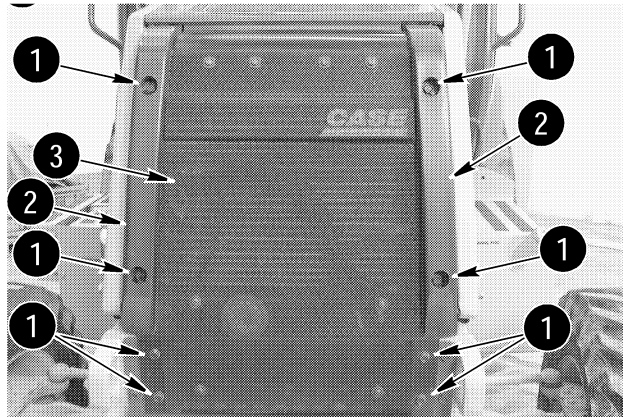

BD01B356

Remove the bolts (1), bumpers (2), and the grille (3) from the front of the machine.

STEP 3

Open the hood. Connect acceptable lifting equipment to the hood.

STEP 4

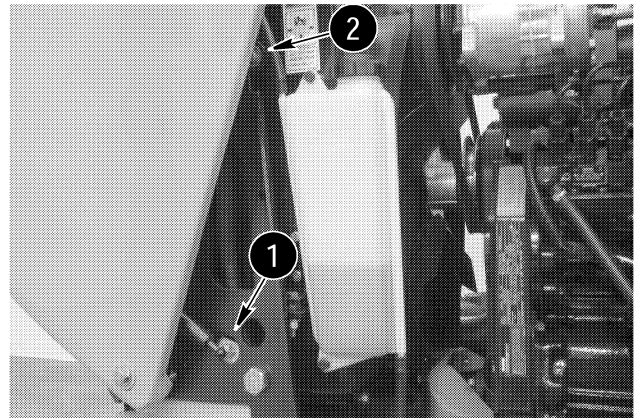

BD01D045

Do the following procedure to remove the hood.

- A. Remove the retainers from the hood struts (1) and disconnect the hood struts from the stud.
- B. Disconnect the hood cable (2) from the radiator shroud.
- C. Carefully lower the hood back to the closed position.

STEP 5

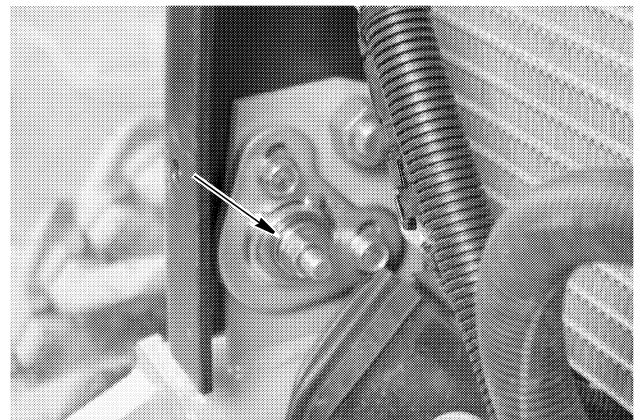

BD01B311

Remove the bolts, washers, and nuts from the pivot point on the hood.

STEP 6

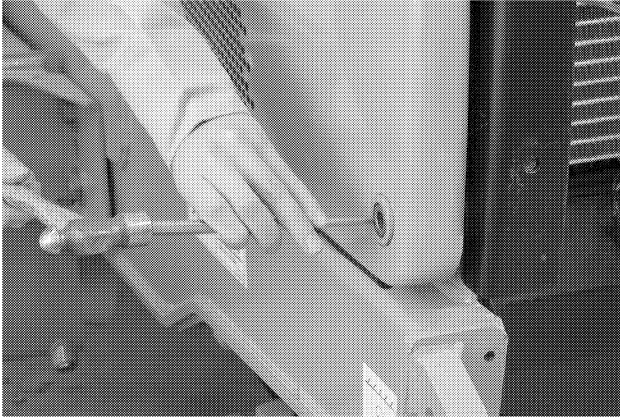

BD01B311

Drive the pivot tubes out of the hood pivot point. Remove the hood from the machine.

STEP 7

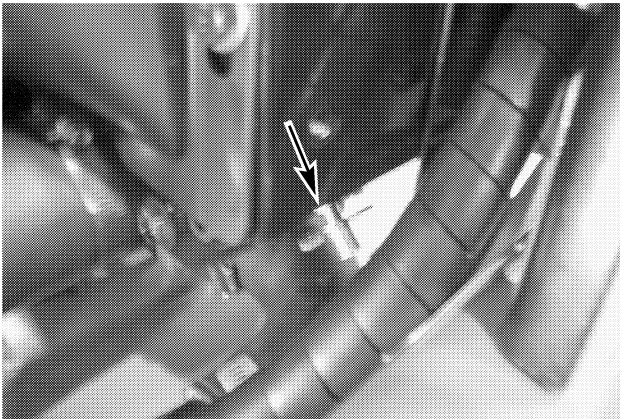

BD01B322

Slowly remove the radiator cap. Install a hose on the drain valve and drain the radiator into a clean container that holds approximately 17 litres (18 U.S. quarts).

NOTE: During installation, fill the radiator and coolant reservoir completely. See Section 1002 for coolant specifications. Start and run the engine until the coolant is at operating temperature. Stop the engine and check for leakage. When the coolant is cold, check the coolant reservoir level. Add coolant as required.

STEP 8

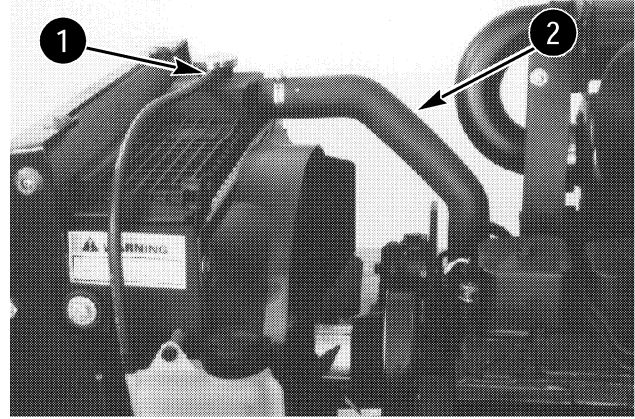

BP9502292

Disconnect the overflow hose (1) from the radiator neck. Loosen the clamp and disconnect the upper radiator hose (2).

STEP 9

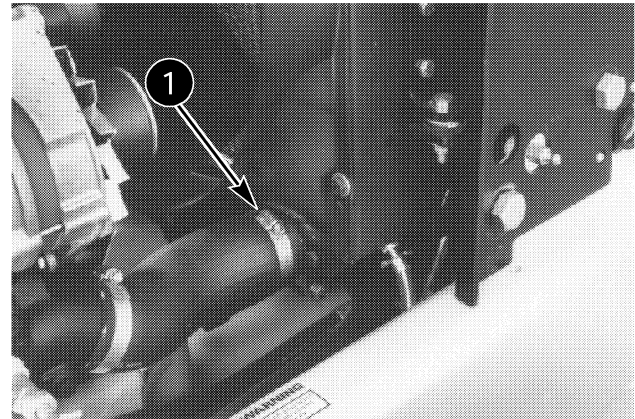

BP9502290

Loosen the clamp (1) and disconnect the lower radiator hose.

STEP 10

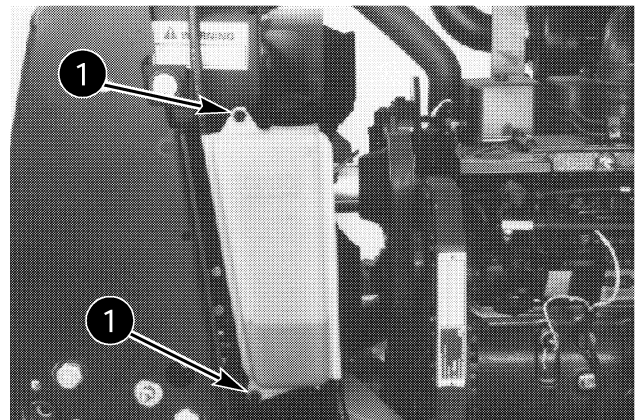

BP9502291

Remove the bolts (1), spacers, washers, and coolant reservoir from the machine.

NOTE: During installation tighten the bolts to a torque of 5 to 6 Nm (44 to 53 pound-inches).

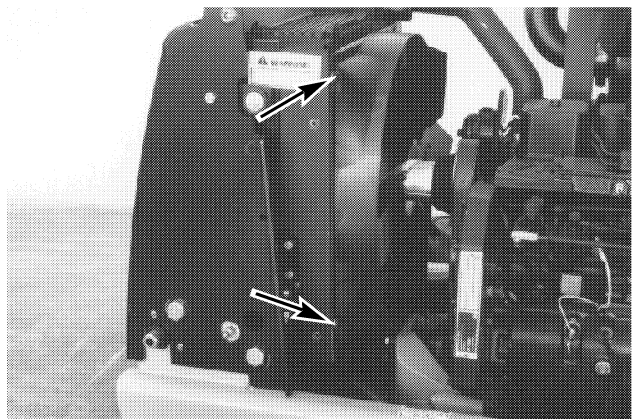
STEP 11

BP9502293

Remove the hardware from the fan shroud. Move the fan shroud away from the radiator.

NOTE: During installation tighten the bolts to a torque of 26 to 31 Nm (19 to 23 pound-feet).

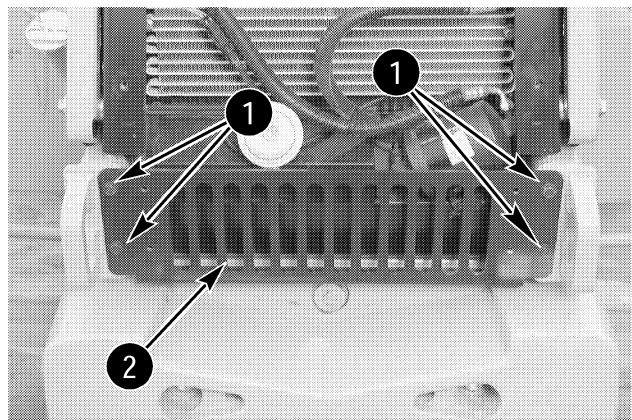
STEP 12

BD01B309

Remove the bolts (1) and pump guard (2) from the machine.

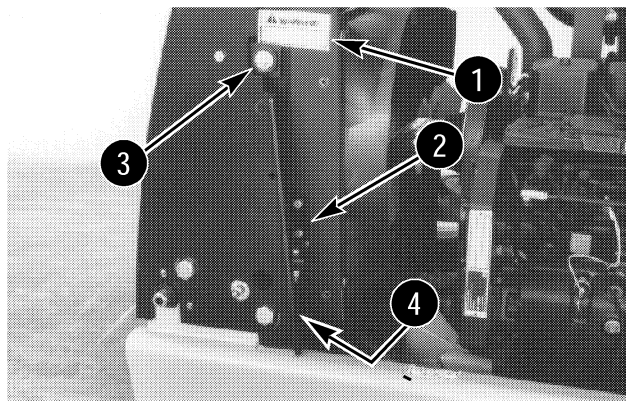
STEP 13

BP9502293

Use a sharp knife and cut the warning decal (1). Remove the bolts that fasten the lower brackets (2) to the radiator. Remove the hardware and the lower brackets (2) from the radiator shroud. Remove the bolts and flat washers that fasten the upper brackets (3) to the radiator. Remove the bolts and flat washers (4) that fastens the condenser if equipped and oil cooler to the radiator. Lift the radiator straight up and remove the radiator from the machine.

NOTE: Installation of the radiator is the reverse of removal.

ENGINE REMOVAL

Put identification tags on all disconnected hoses and wires. Close disconnected hoses and fittings with caps and plugs.

NOTE: *The photos in this procedure may be different from your machine and are for reference only.*

STEP 1

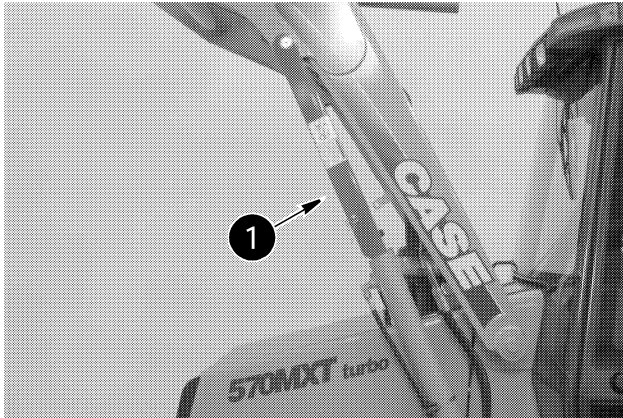

BD01D042

Park the machine on a level surface. Raise the loader and lock the support strut to hold the loader.

STEP 2

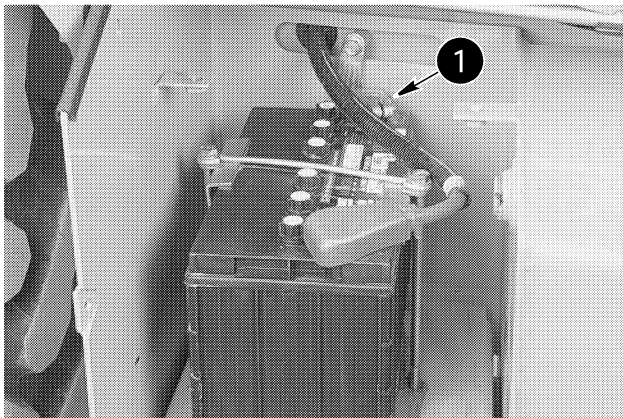

BD00F122

Remove the battery cover from the right step. If the machine has only one battery, disconnect the negative battery cable from the battery.

STEP 3

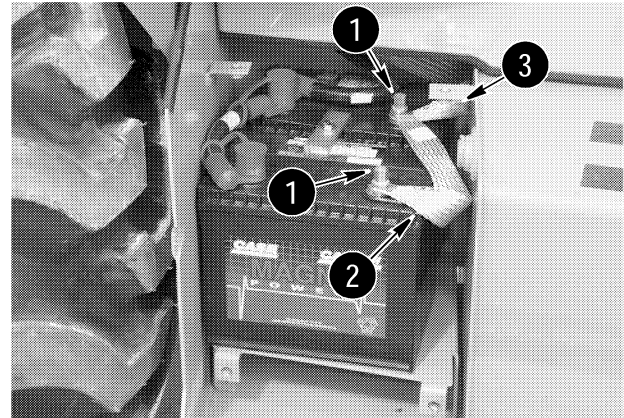

BD00H122

If the machine has two batteries, remove the terminal nuts (1). Remove the jumper cable (2) from the batteries. Remove the negative ground strap (3) from the battery.

STEP 4

Drain the oil from the hydraulic reservoir.

NOTE: *During installation fill the hydraulic reservoir with the oil specified in section 1002 of this manual.*

STEP 5

If the machine is equipped with air conditioning. See Section 9004 and recover the coolant from the air conditioning system.

NOTE: *During installation see Section 9004 and recharge the air conditioning system.*

STEP 6

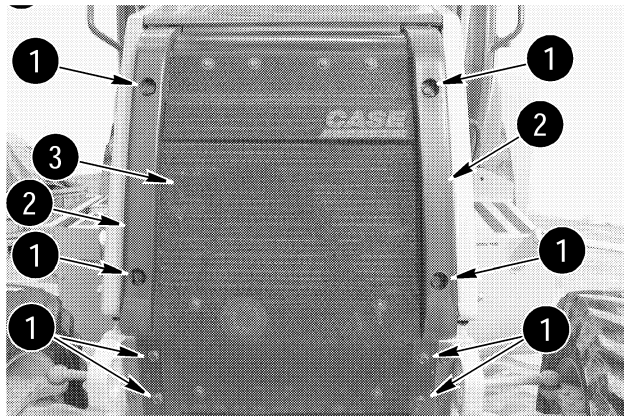

BD01B356

Remove the bolts (1), bumpers (2), and the grille (3) from the front of the machine.

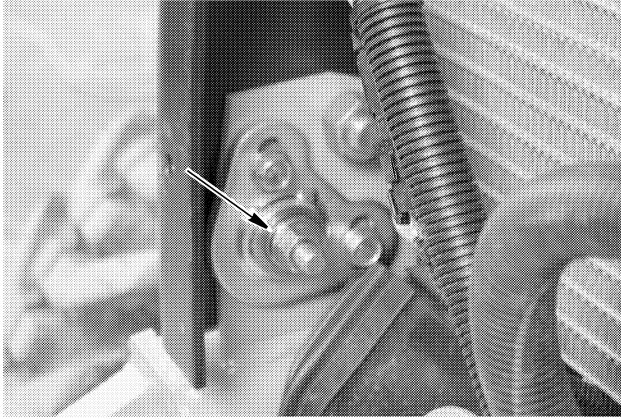
STEP 7

BD01B311

Remove the bolts, washers, and nuts from the pivot point on the hood.

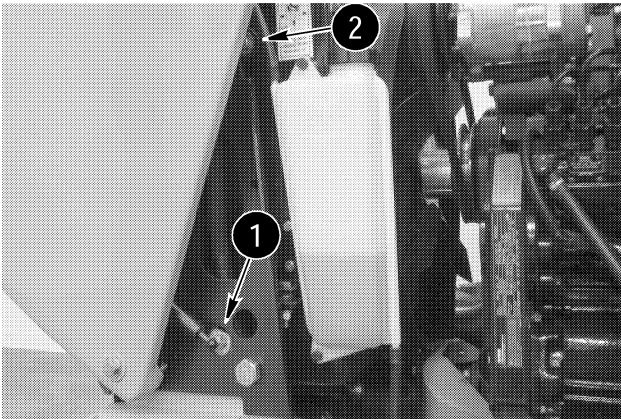
STEP 8

BD01B357

Do the following procedure to remove the hood.

- D. Remove the retainers from the hood struts (1) and disconnect the hood struts from the stud.
- E. Disconnect the hood cable (2) from the radiator shroud.
- F. Carefully lower the hood back to the closed position.

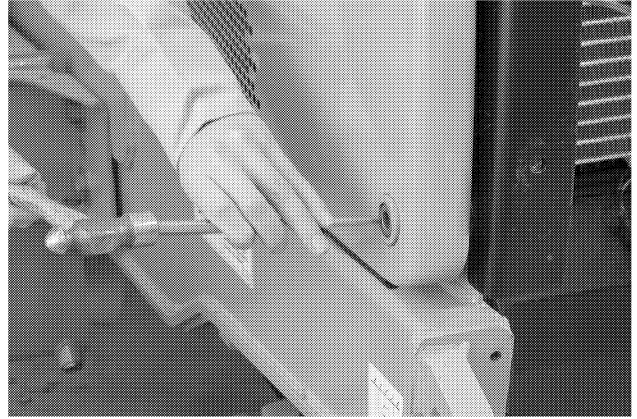
STEP 9

BD01B311

Drive the pivot tubes out of the hood pivot point.

STEP 10

Use acceptable lifting equipment and remove the hood from the machine.

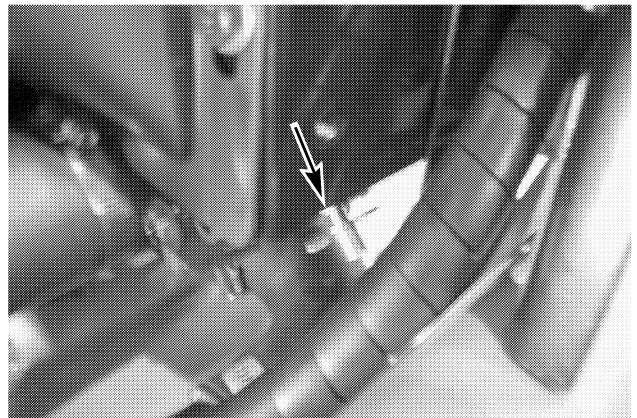
STEP 11

BD01B322

Slowly remove the radiator cap. Install a hose on the drain valve and drain the radiator into a clean container that holds approximately 17 litres (18 U.S. quarts).

NOTE: During installation, fill the radiator and coolant reservoir completely with coolant. See Section 1002 for coolant specifications. Start and run the engine until the coolant is at operating temperature. Stop the engine and check for leakage. When the coolant is cold, check the coolant reservoir level. Add coolant as required.

STEP 12

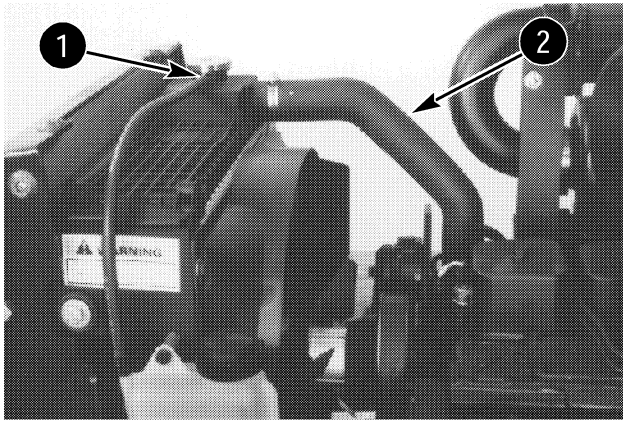

BP9502292

Disconnect the overflow hose (1) from the radiator neck. Loosen the clamp and disconnect the upper radiator hose (2).

STEP 13

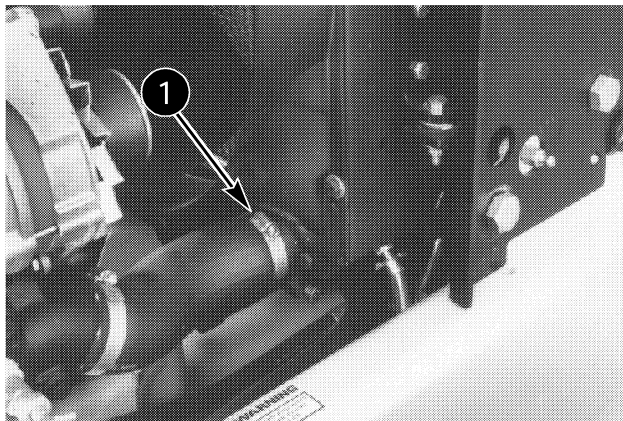

BP9502290

Loosen the clamp (1) and disconnect the lower radiator hose.

NOTE: The following photo shows the coolant reservoir removed from the machine. It is not necessary to remove the coolant reservoir from the machine.

STEP 14

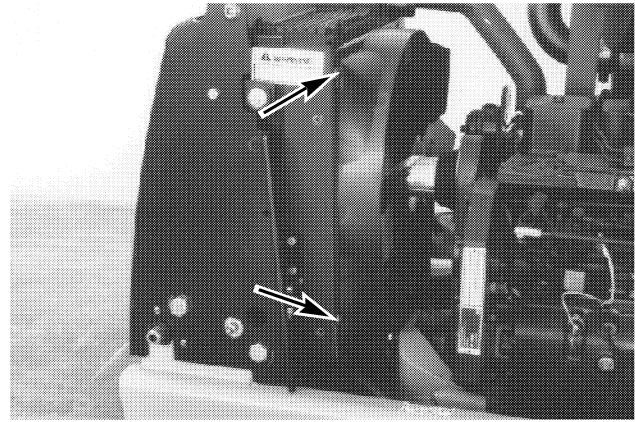

BP9502293

Remove the hardware from the fan shroud. Move the fan shroud away from the radiator.

STEP 15

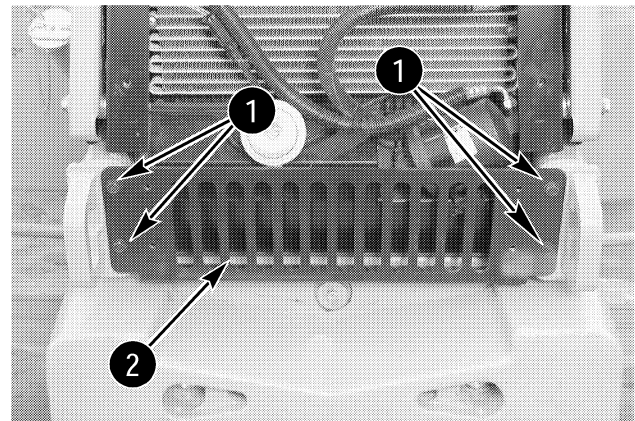

BD01B309

Remove the bolts (1) and pump guard (2) from the machine.

STEP 16

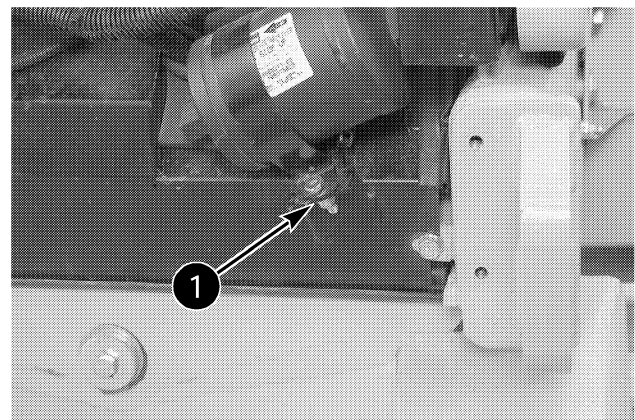

BD01B310

If the machine is equipped with air conditioning. Remove the self-locking nut and clamp from the drier.

NOTE: During installation tighten the self-locking nut to a torque of 26 to 31 Nm (19 to 23 pound-feet).

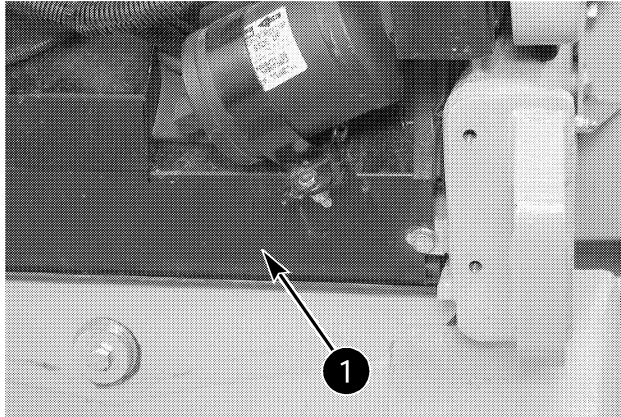
STEP 17

BD01B310

Disconnect the wires from the horn on the baffle plate (1). Loosen and remove the hardware that fastens the baffle plate (1) to the front of the machine. Remove the baffle plate (1) from the machine.

STEP 18

If the machine is equipped with air conditioning. Disconnect the electrical connector for the drier. Disconnect the hoses from the drier. Remove the drier from the machine.

STEP 19

If your machine is equipped with air conditioning disconnect the electrical connector for the high pressure cut-out switch.

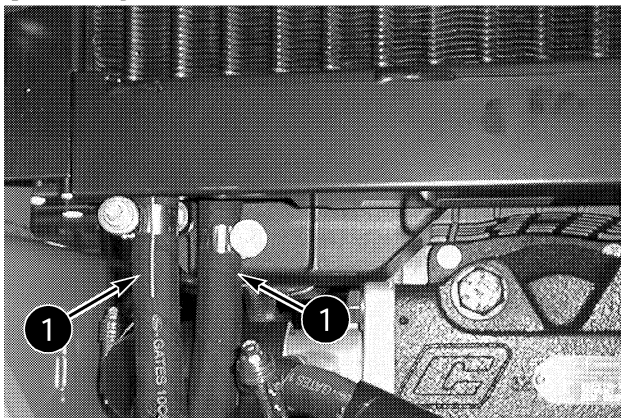
STEP 20

GS99D801

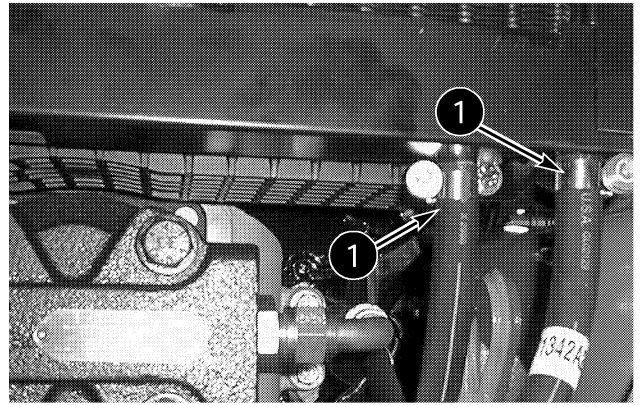

GS99D802

1. OIL COOLER HOSES

Disconnect the hoses from both sides of the hydraulic oil cooler. Identify each hose with its location of removal. Cap the fittings and plug the hoses.

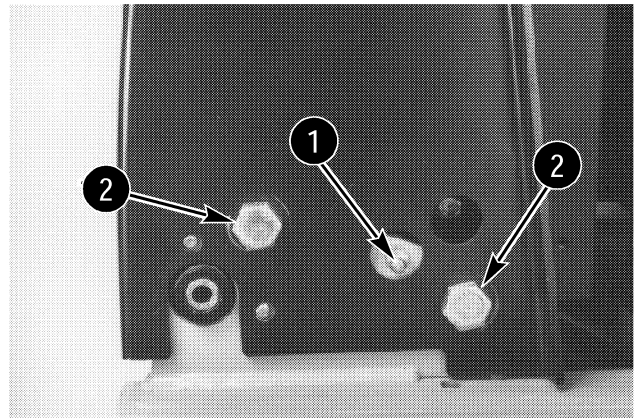
STEP 21

BP9503100

Remove the studs (1). Remove the bolts (2) and nuts that fasten the radiator shroud to the frame.

NOTE: During installation tighten the studs (1) to a torque of 52 to 61 Nm (38 to 45 pound-feet). Tighten the bolts (2) to a torque of 434 to 515 Nm (320 to 380 pound-feet).

STEP 22

Remove the radiator shroud, radiator, oil coolers and if equipped with air conditioning the condenser as an assembly.

STEP 23

Remove the fan shroud from the fan.

STEP 24

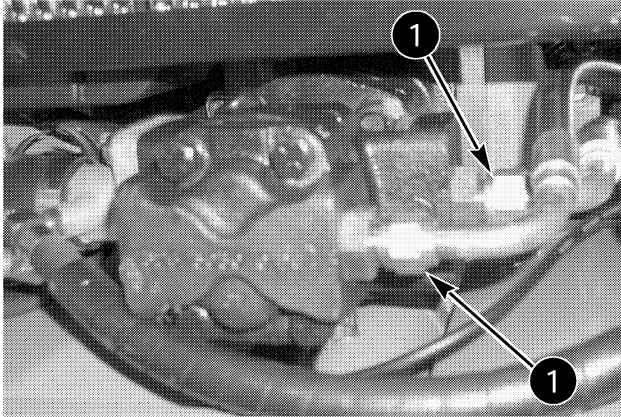

BD01B314

Disconnect the hoses (1) from the LH side of the pump.

STEP 25

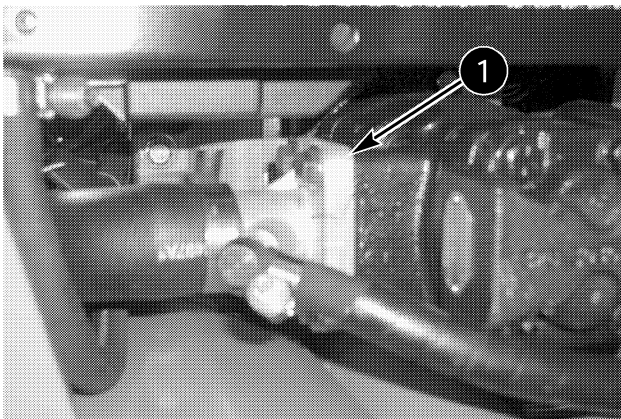

BD01B315

Remove the bolts and lock washers that fasten the fitting (1) on the RH side of the pump.

STEP 26

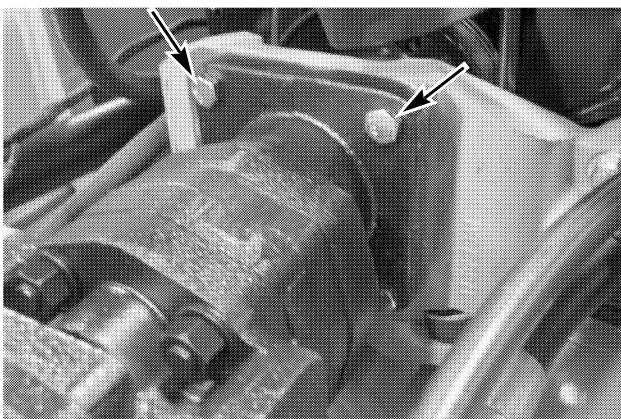

BD01B328

Loosen and remove the bolts that fasten the equipment pump to the pump mounting bracket. Remove the equipment pump from the machine.

STEP 27

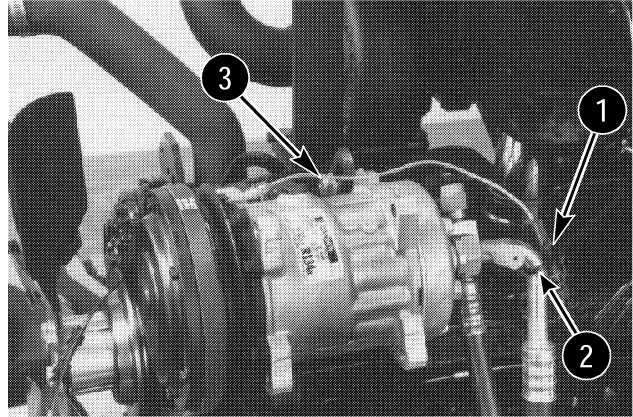

BP9503116

If the machine is equipped with air conditioning, disconnect the electrical connector (1). Remove the tie strap (2). Disconnect the hoses from the compressor.

STEP 28

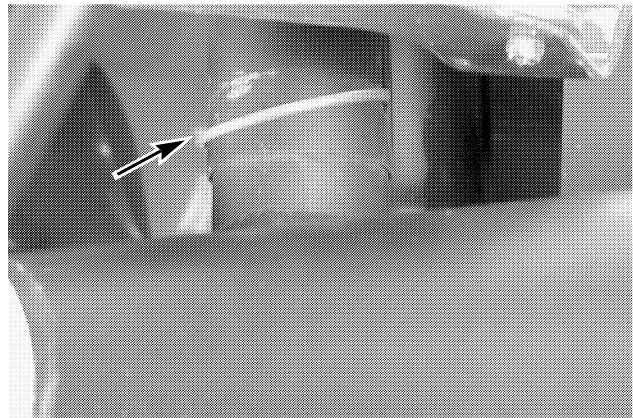

BD01B306

Loosen the clip for the exhaust pipe at the muffler. Remove the exhaust pipe from the muffler.

STEP 29

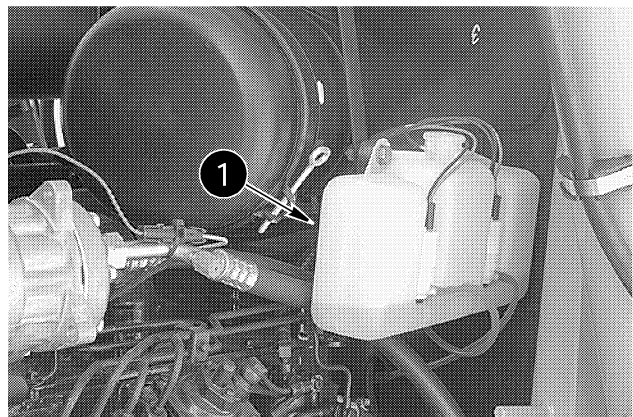

BK97K213

Remove the windshield washer reservoir (1).

STEP 30

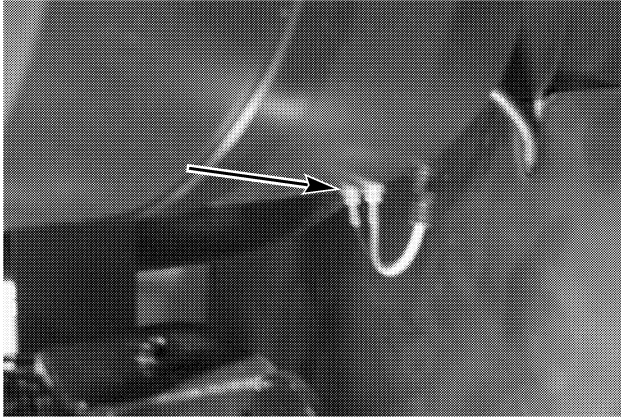

BD01B324

Remove the tie strap. Disconnect the electrical connectors for the air restriction indicator.

STEP 31

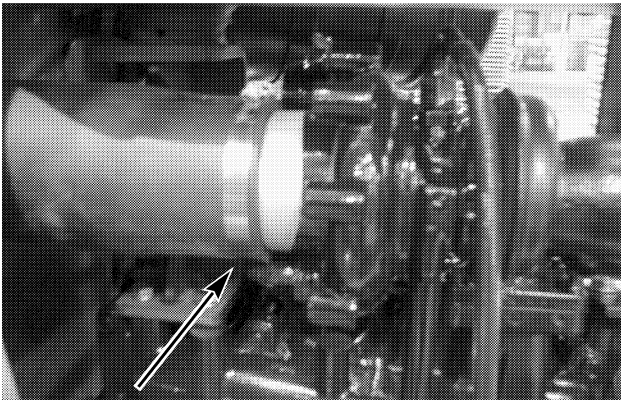

BD01B323

If the machine is equipped with turbocharger, loosen the clamp on the air cleaner hose at the turbocharger. Disconnect the air cleaner hose from the turbocharger.

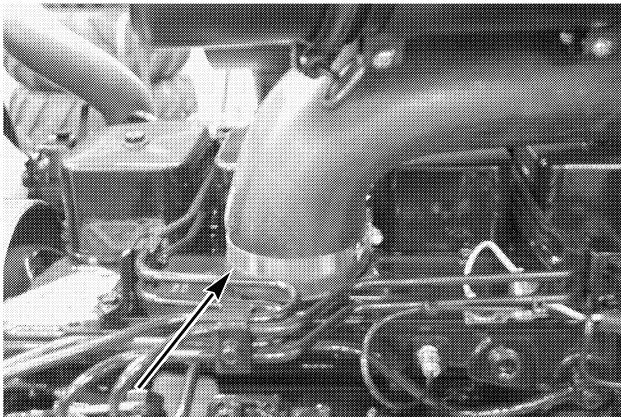

BD01B366

If the machine is not equipped with turbocharger, loosen the clamp on the air cleaner hose at the intake manifold. Disconnect the air cleaner hose from the intake manifold.

STEP 32

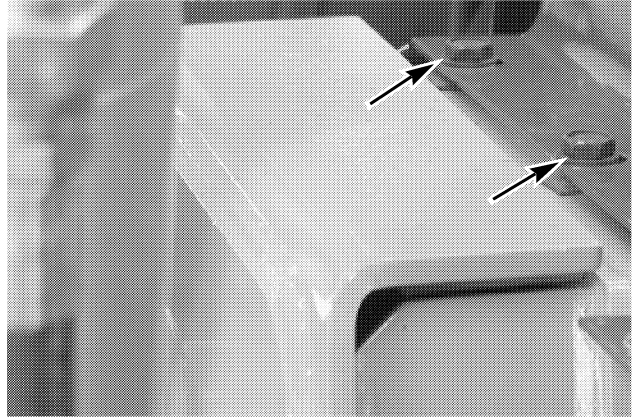

BD01B307

Remove the bolts and flat washers that fasten the cover to uprights. Remove the cover and air cleaner as an assembly.

STEP 33

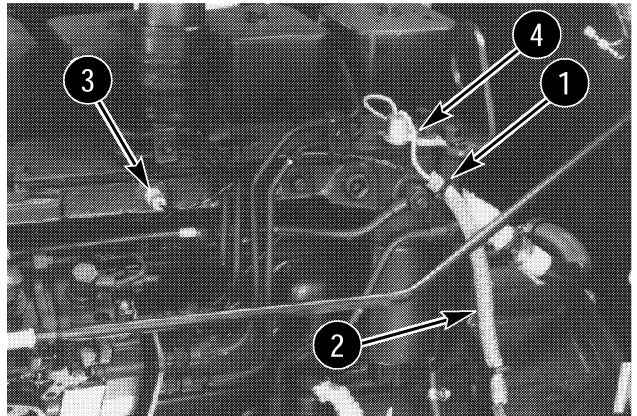

BP9502303

If the machine has ether injection, remove the tie straps (1) and sleeve (2) from the tube (3) and wire (4). Disconnect the tube (3) and the wire (4).

STEP 34

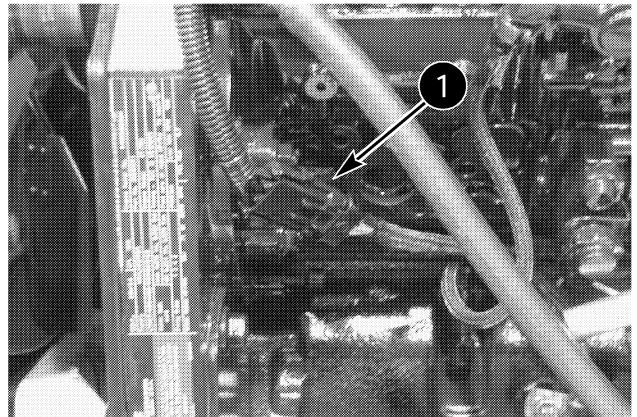

BD01B365

Disconnect the electrical connector for the fuel injection pump (1).

STEP 35

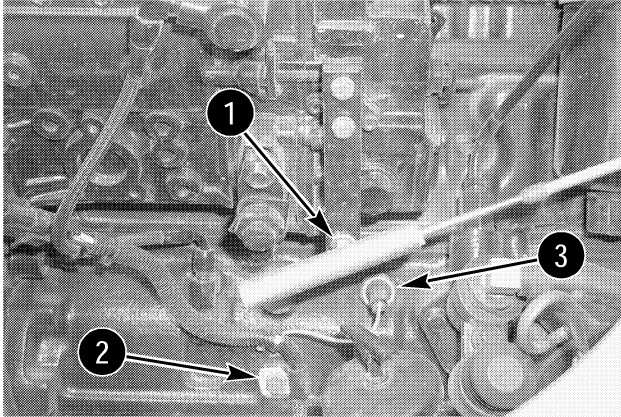

BD01B375

Disconnect the throttle rod (1). Disconnect the wiring clamp (2). Disconnect the wire from the oil pressure sender (3).

STEP 36

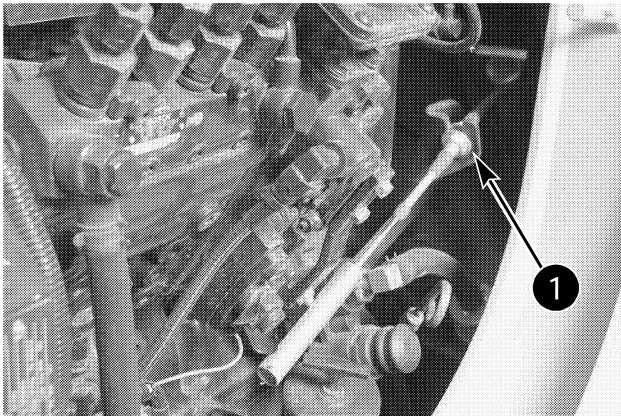

BD01B377

Disconnect the throttle cable from the mounting bracket (1).

STEP 37

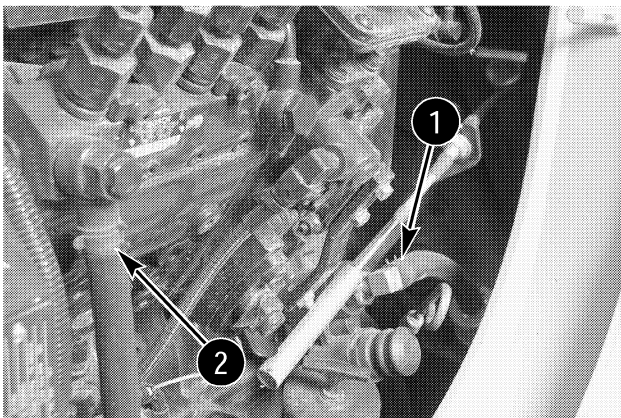

BD01B377

Disconnect the fuel lines (1) and (2).

STEP 38

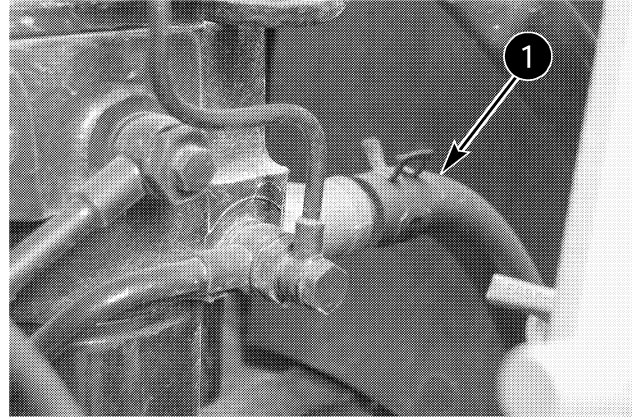

BD01B378

Disconnect the heater hose (1), if equipped.

STEP 39

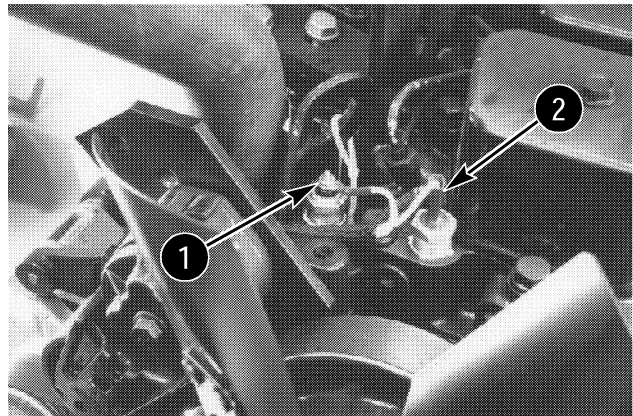

BP9502298

Disconnect the coolant temperature sender (1) and coolant temperature switch (2).

STEP 40

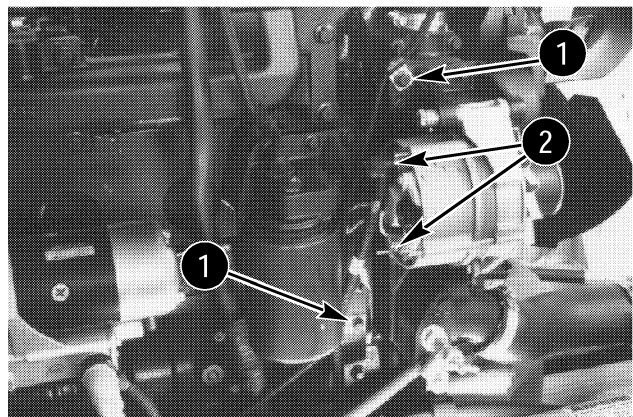

BP9502296

Remove the harness clamps (1). Disconnect the wires (2) from the alternator.

Please click here and go
back to our website.

BUY NOW

Then Instant Download the
Complete Manual.

Thank you very much!